

**CATALOGO PARTI DI RICAMBIO - PARTS CATALOG
CATALOGUE PIECES DE RECHANGE - ERSATZTEILKATALOG
CATALOGO PIEZAS DE REPUESTO**

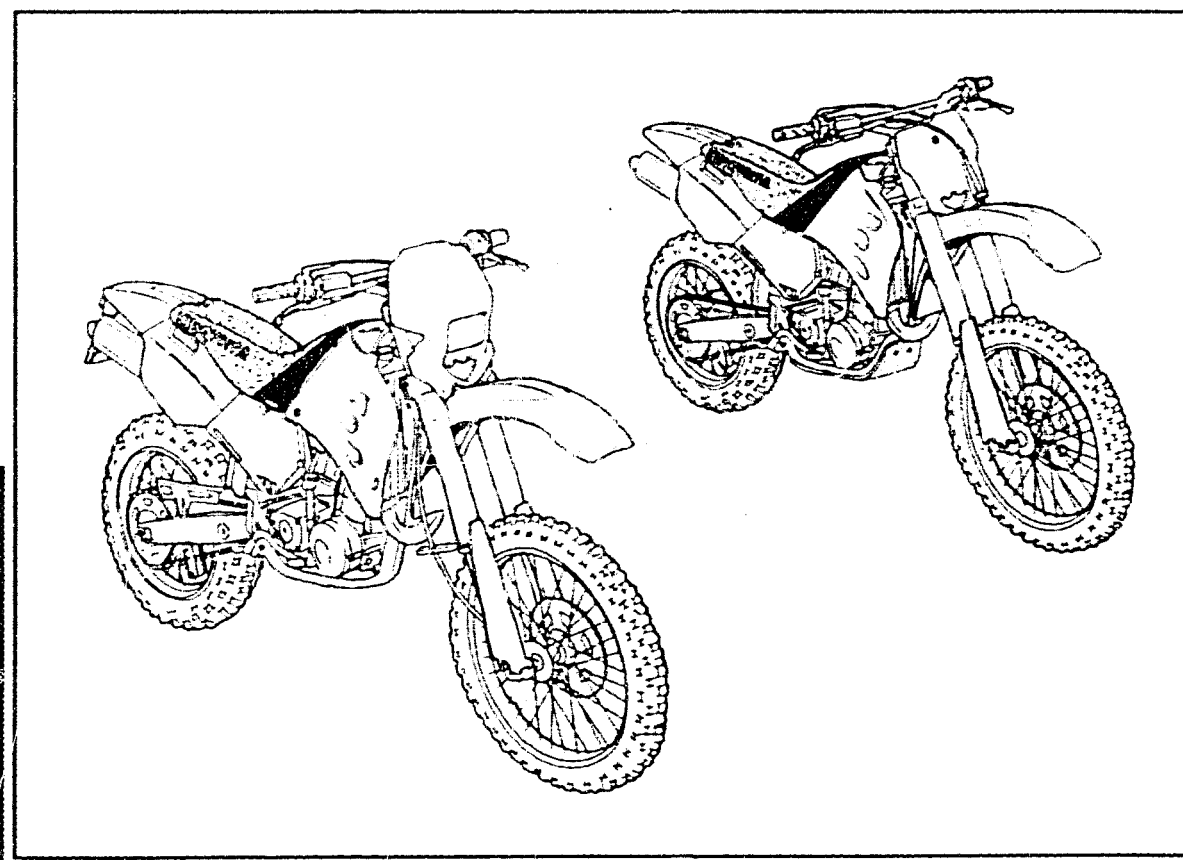
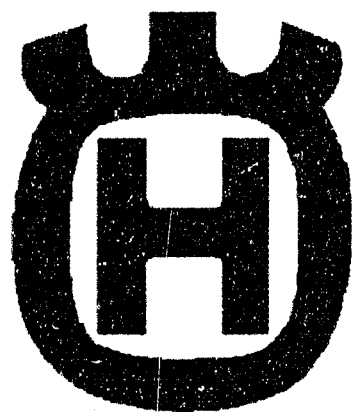

Husqvarna

INFORMAZIONI GENERALI

Il presente catalogo serve per richiedere con esattezza le parti di ricambio. Nelle ordinazioni indicare:

- 1) il numero di codice dei particolari seguito dalla descrizione;
- 2) il colore per i pezzi verniciati o comunque colorati;
- 3) il numero di matricola del motociclo, stampigliato sul canotto di sterzo. Le indicazioni destra e sinistra si riferiscono ai lati del veicolo rispetto al senso di marcia.

GENERAL INFORMATION

The present spare parts list enables one to order exactly the right spare parts.

When ordering specify:

- 1) the part's code number followed by its description;
- 2) indicate colour for painted or coloured parts;
- 3) the motorcycle's serial number, stamped on the steering head. References to right and left apply to the vehicle in terms of its direction of movement.

INFORMATIONS GENERALES

Ce catalogue permet de commander correctement les pièces de rechange. Les commandes doivent être passées en indiquant:

- 1) le numéro de code des pièces détachées suivi de leur description;
- 2) le couleur des pièces peintes ou colorés;
- 3) le matricule de la moto, estampillé sur la tige du guidon. Droite et gauche sont les côtés du véhicule par rapport au sens de la marche.

ALLGEMEINE HINWEISE

Dieser Ersatzteilkatalog dient zur genauen Angabe der Teile bei Ersatzteilbestellungen.

Bei Ersatzbestellung ist folgendes anzugeben:

- 1) Die Bestellnummer der Ersatzteile mit der entsprechenden Beschreibung;
- 2) Farbe für lackierte und farbige Teile angeben;
- 3) Die Seriennummer des Motorrads, die am Lenkrohr eingepreßt ist. Die Angaben rechts und links beziehen sich auf das Fahrzeug in Fahrrichtung.

INFORMACIONES GENERALES

El presente catálogo sirve para pedir con exactitud las partes de recambio. En los pedidos se debe indicar:

- 1) el número de código de la parte y a continuación la descripción;
- 2) el color para las piezas barnizadas o coloreadas;
- 3) el número de matrícula de la motocicleta, estampado en el tubo de dirección. Las indicaciones derecha e izquierda se refieren a los lados del vehículo respecto del sentido de marcha.

NOTE - LIST - NOTES - NOTE - NOTAS:

- A : In alternativa - In alternative - En alternative
Wahlweise - En alternativa
- C : Modello TC - TC model - Modèle TC - Modell TC
Modélo TC
- D : In dotazione - To issue - En nécessaire
Ausrüstungsteile - En dotación
- E : Ad esaurimento - To fell out - A' finir - Erschöpfung
A agotamiento
- F : Fornire assieme - Supply unitedly - Fournir ensemble
Wird zusammen geliefert - Equipar juntos
- N : Non fornito - Not supplied - Ne pas fournir
Keine Lieferende - No equiparado
- R : A richiesta - Upon request - Sur demande
Auf anfrage - Bajo pedido
- S : Di serie - Supplied - De série - Standard - De serie
- Sc : Di serie per modello TC - Supplied for TC model
De série pour modèle TC - Standard für modell TC
De serie por modélo TC
- Sw : Di serie per modello TE - Supplied for TE model
De série pour modéle TE - Standard für modell TE
De serie por modélo TE
- U : Solo per U.S.A. - Only for U.S.A. - Seulement pour U.S.A.
Nur für U.S.A. - Solo por U.S.A.
- X : Non per U.S.A. - Not for U.S.A. - Ne pas pour U.S.A.
Keine für U.S.A. - No por U.S.A.
- Y : Non per TC - Not for TC - Ne pas pour TC
Keine für TC - No por TC
- W : Modello TE - TE model - Modèle TE - Modell TE
Modélo TE
- Z : n° denti, number of teeth, numéro dents, Zähne nummer
número dientes
- A : Austria, Austria, Autriche, Österreich, Austria
- AUS : Australia, Australia, Australie, Australien, Australia
- B : Belgio, Belgium, Belgique, Belgien, Bélgica
- BR : Brasile, Brazil, Brasile, Brasilien, Brasil
- CND : Canada, Canada, Canada, Kanada, Canadá
- CH : Svizzera, Switzerland, Suisse, Schweizer, Suiza
- D : Germania, Germany, Allemagne, Deutschland, Alemania
- E : Spagna, Spain, Espagne, Spanien, España
- F : Francia, France, France, Frankreich, Francia
- GB : Gran Bretagna, Great Britain, Grand Bretagne
Groos Britan, Gran Bretaña
- I : Italia, Italy, Italie, Italien, Italia
- TA : Tahiti, Tahiti, Tahiti, Tahiti, Tahiti
- USA : Stati Uniti d'America, United States of America
Etats Units d'Amerique,
Vereinigta Staaten von Amerika, Estados Unidos
- SF : Finlandia, Finald, Finlande, Finnland, Finlandia

- Il n° di matricola iniziale del modello TE 610/99 è ZCGH600AAXV003627
Il n° di matricola iniziale del modello TE 610/99 U.S.A. è ZCGTE610*XV060076
Il n° di matricola iniziale del modello TC 610/99 è ZCGH600AAXV051771
Il n° di matricola iniziale del modello TE 410/99 è ZCGH500AAXV001693
Il n° di matricola iniziale del modello TE 410/99 U.S.A. è ZCGTE410*XV070066

The initial serial number for the TE 610/99 model is ZCGH600AAXV003627
The initial serial number for the TE 610/99 U.S.A. model is ZCGTE610*XV060076
The initial serial number for the TC 610/99 model is ZCGH600AAXV051771
The initial serial number for the TE 410/99 model is ZCGH500AAXV001693
The initial serial number for the TE 410/99 U.S.A. model is ZCGTE410*XV070066

Le matricule initial du modèle TE 610/99 est ZCGH600AAXV003627
Le matricule initial du modèle TE 610/99 U.S.A. est ZCGTE610*XV060076
Le matricule initial du modèle TC 610/99 est ZCGH600AAXV051771
Le matricule initial du modèle TE 410/99 est ZCGH500AAXV001693
Le matricule initial du modèle TE 410/99 U.S.A. est ZCGTE410*XV070066

Die Seriennummer des Modells TE 610/99 beginnt mit ZCGH600AAXV003627
Die Seriennummer des Modells TE 610/99 U.S.A. beginnt mit ZCGTE610*XV060076
Die Seriennummer des Modells TC 610/99 beginnt mit ZCGH600AAXV051771
Die Seriennummer des Modells TE 410/99 beginnt mit ZCGH500AAXV001693
Die Seriennummer des Modells TE 410/99 U.S.A. beginnt mit ZCGTE410*XV070066

El n° de matrícula inicial de la motocicleta TE 610/99 es ZCGH600AAXV003627
El n° de matrícula inicial de la motocicleta TE 610/99 U.S.A. es ZCGTE610*XV060076
El n° de matrícula inicial de la motocicleta TC 610/99 es ZCGH600AAXV051771
El n° de matrícula inicial de la motocicleta TE 410/99 es ZCGH500AAXV001693
El n° de matrícula inicial de la motocicleta TE 410/99 U.S.A. es ZCGTE410*XV070066

Dati indicativi soggetti a modifiche senza impegno di preavviso.
All data are subject to modification without prior notice.
Données indicatif sujet au modifications sans obligation de préavis.
Anderungen vorbehalten.
Datos indicativos sujetos a modificaciones sin compromiso de preaviso.



INDICE – INDEX – INDEX – INHALTSVERZEICHNIS - INDICE

TE - TE U.S.A 410 - 610 / 99
TC 610 / 99

Tavola
Drawing
Table
Bild
Tabla

	Denominazione	Description	Designation	Bezeichnung	Denominacion	Pag
1	ATTREZZI DI ASSISTENZA	SERVICE TOOLS	OUTILS D'ASSISTANCE	HILFAUSRUSTUNG	HERRAMIENTAS DE ASISTENCIA	5
2	TESTA, CILINDRO	CYLINDER HEAD, CYLINDER	CULASSE, CYLINDRE	ZYLINDERKOPF, ZYLINDER	CULATA, CILINDRO	7
3	DISTRIBUZIONE	VALVE TIMING	DISTRIBUTION	VENTILSTEUERUNG	DISTRIBUCION	11
4	PISTONE, MANOVELLISMO	PISTON, CRANKSHAFT	PISTON, VILEBREQUIN	KOLBEN, KURBELWELLE	PISTON, PALANCAS	15
5	RAFFREDDAMENTO	COOLING	REFROIDISSEMENT	WASSERKÜHLUNG	ENFRIAMIENTO	17
6	SEMICARTER DESTRO	R.H. HALF CRANKCASE	CARTER D.	GEHAUSEDECKEL R.	BANCADA DER.	21
7	SEMICARTER SIN., AVVIAMENTO	L.H. HALF CRANKCASE, STARTING	CARTER G., DEMMARRAGE	GEHAUSEDECKEL L., ANLASSER	BANCADA IZQ., ARRANQUE	25
8	CAMBIO, COMANDO CAMBIO, FRIZIONE - Modello TE	TRANSMISSION, SHIFTER, CLUTCH - TE Model	BOITE DE VITESSE, COMMANDE DE VITESSE, EMBRAYAGE - Modèle TE	WECHSELGETRIEBE, GANG - SCHALTUNG, KUPPLUNG - Modell TE	CAMBIO, MANDO CAMBIO, ENBRAGUE - Modelo TE	31
8A	CAMBIO, COMANDO CAMBIO, FRIZIONE - Modello TC	TRANSMISSION, SHIFTER, CLUTCH - TC Model	BOITE DE VITESSE, COMMANDE DE VITESSE, EMBRAYAGE - Modèle TC	WECHSELGETRIEBE, GANG - SCHALTUNG, KUPPLUNG - Modell TC	CAMBIO, MANDO CAMBIO, ENBRAGUE - Modelo TC	35
9	ACCENSIONE	IGNITION	ALLUMAGE	ZÜNDUNG	ENCENDIDO	39
10	CARBURATORE - Modello TE-TE U.S.A. 610	CARBURETOR - TE-TE U.S.A. 610 Model	CARBURATEUR - Modèle TE-TE U.S.A. 610	VERGASER - Modell TE-TE U.S.A. 610	CARBURADOR - Modelo TE-TE U.S.A. 610	41
10A	CARBURATORE - Modello TC	CARBURETOR - TC Model	CARBURATEUR - Modèle TC	VERGASER - Modell TC	CARBURADOR - Modelo TC	45
10B	CARBURATORE - Modello TE-TE U.S.A. 410	CARBURETOR - TE-TE U.S.A. 410 Model	CARBURATEUR - Modèle TE-TE U.S.A. 410	VERGASER - Modell TE-TE U.S.A. 410	CARBURADOR - Modelo TE-TE U.S.A. 410	51
11	FILTRO ARIA	AIR FILTER	FILTRE AIRE	AIRFILTER	FILTRO DE AIRE	57
12	TELAIO, PEDANE	FRAME, FOOT RESTS	CADRE, REPOSE PIEDS	RAHMEN, FUSSBRETT	BASTIDOR, REPOSAPIES	59
13	SOSPENSIONE ANTERIORE Ø 45	FRONT FORK ASSEMBLY Ø 45	SUSPENSION AVANT Ø 45	VORDERTELESKOPGABEL Ø 45	SUSPENSION DELANTERA Ø 45	63
14	FORCELLONE	SWING ARM	FOURCHE	GABEL	HORQUILLA	71
15	AMMORTIZZATORE POSTERIORE	REAR SUSPENSION	SUSPENSION ARRIÈRE	HINTERHAUFHANGUNG	SUSPENSION TRASERA	75
16	LEVERAGGI SOSPENSIONE POST.	REAR SUSPENSION LINKAGE	LEVIER SUSPENSION ARRIERE	HEBELWERK HINTERHAUFHANGUNG	PALANCA SUSPENSION TRASERA	79
17	MANUBRIO E COMANDI	HANDLEBAR AND CONTROLS	GUIDON ET COMMANDES	LENKER UND STEUERORGANE	MANILLAR Y MANDOS	81
18	FRENO IDRAULICO POSTERIORE	REAR HYDRAULIC BRAKE	FREIN HYDRAULIQUE ARRIERE	HINTERBREMSE	FRENO HIDRAULICO TRASERO	83
19	PANNELLI, PARAFANGHI, SELLA	PANEL, FENDERS, SEAT	PANNEAU, GARDE-BOUES, SIEGE	STREIFEN, KOTFLUGEL, SATTEL	PANELES, GUARDABARROS, SILLIN	87
20	SERBATOIO	GAS TANK	RESERVOIR	KRAFTSTOFFBEHALTER	DEPOSITO	89
20A	SERBATOIO MAGGIORATO	LARGE GAS TANK	RESERVOIR DE PULS GRANDE CAPACI.	UEBERDIMENSIONIERTER BEHALTER	DEPOSITO AMBLIADO	91
21	SCARICO	EXHAUST SYSTEM	TUYAU D'ÉCHAPPEMENT	AUSPUFFROHR	TUBO DE ESCAPE	93
22	FRENO IDRAULICO ANTERIORE	FRONT HYDRAULIC BRAKE	FREIN HYDRAULIQUE AVANT	VORTERBREMSE	FRENO HIDRAULICO DELANTERO	95
22A	RUOTA ANTERIORE	FRONT WHEEL	ROUE AVANT	VORTERRAD	RUEDA DELANTERA	99
23	RUOTA POSTERIORE	REAR WHEEL	ROUE ARRIERE	HINTERRAD	RUEDA TRASERA	101
24	CONTACHILOMETRI, LIBRETTO USO E MANUTENZIONE, AVVIS ACUSTICO	SPEEDOMETER, OWNER'S MANUAL, HORN	COMPTE-KILOMETRES, EMPLOI D'ENTRETIEN, SIGNAL ACOUSTIQUE	TACHOMETER, BETRIEBSANLEITUNG, BREMSSSCHEIBESCHUTZ, HUPE	CUENTA-KILOMETROS, FOLLETO DE INSTRUCCIONES, AVISADOR ACUSTICO	105
25	IMPIANTO Elett., PORTATARGA PORTANUMERO	ELECTRIC SYSTEM, PLATE HOLDER NUMBER HOLDER	INSTALLATION ELECT.,PORTE-BALAI PORTE-NOMBRE	ELEKTR. ANLAGE, SCHILDTRAEGER NUMMERTRAGER	INSTALAC. ELECT., PORTA-MATRICULA PORTA NUMERO	107



INDICE - INDEX - INDEX - INHALTSVERZEICHNIS - INDICE

TE - TE U.S.A 410 - 610 / 99

TC 610 / 99

Tavola Drawing Table Bild Tabla	Denominazione	Description	Designation	Bezeichnung	Denominacion	Pag
26	FRECCE - Modello TE	BLINKER - TE Model	CLIGNOTANT - Modèle TE	BLINKER - Modell TE	INTERMITENTE - Modelo TE	111
27	KIT TRASFORMAZIONE ENDURO	ENDURO TRANSFORMATION KIT	GROUPE TRANSFORMATION ENDURO ..	ENDURO GRUPPE	KIT TRANSFORMACION ENDURO	113
28	DECALCOMANIE - Modello TE	TRANSFER - TE Model	DECALCOMANIE - Modèle TE	ABZIEHBILD - Modell TE	CALCOMANIA - Modelo TE	117
29	DECALCOMANIE - Modello TC	TRANSFER - TC Model	DECALCOMANIE - Modèle TC	ABZIEHBILD - Modell TC	CALCOMANIA - Modelo TC - TE U.S.A.	119

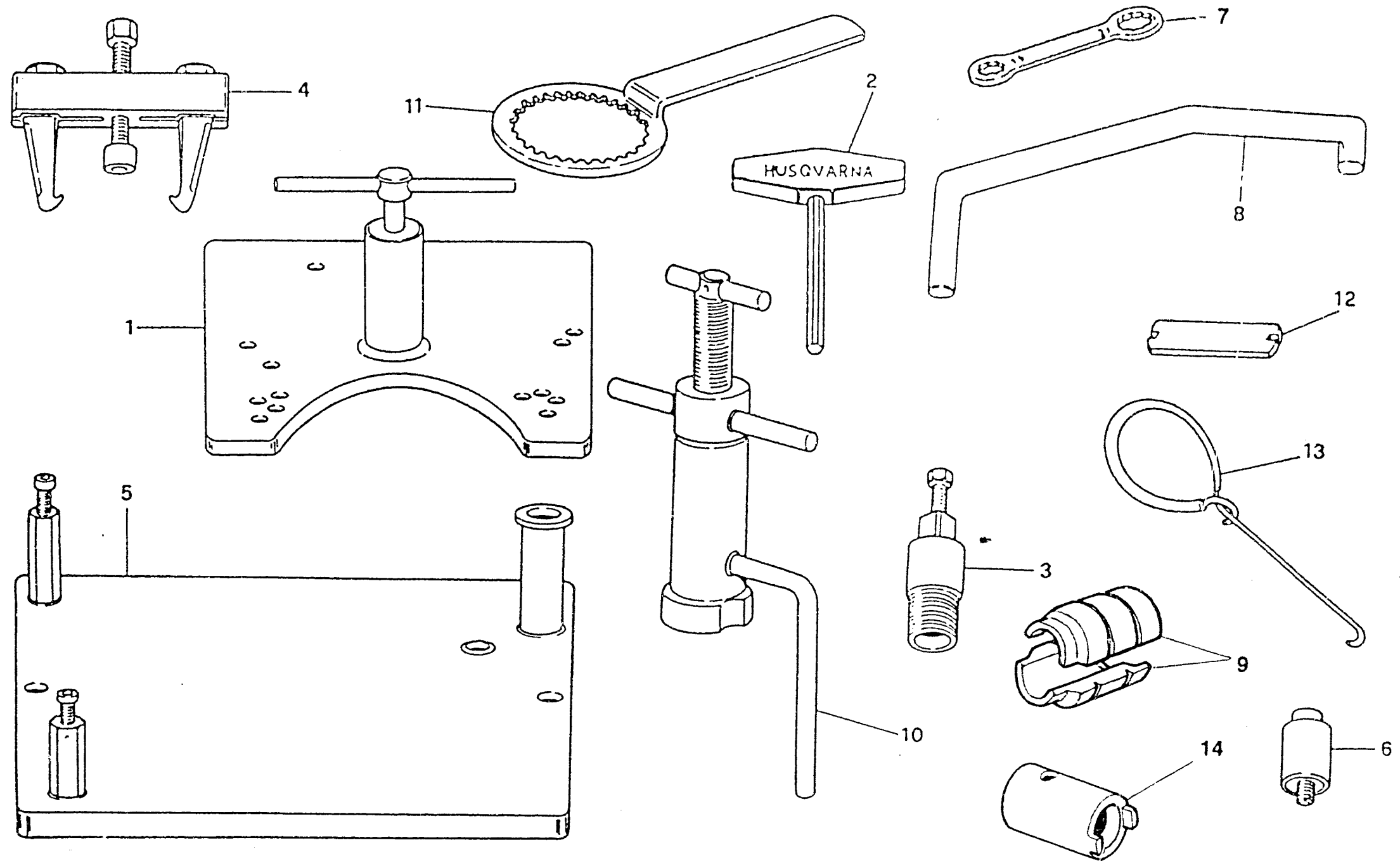



TE - TE U.S.A.
410 - 610 / 99
TC 610 / 99

TAVOLA
DRAWING
TABLE
BILD
TABLA

1

ATTREZZI DI ASSISTENZA - SERVICE TOOLS
OUTILS D'ASSISTANCE - HILFAUSRUSTUNG
HERRAMIENTAS DE ASISTENCIA

Note Notes Notas	Pos. No. Index Pos.	N. Cod. Code No. Nr. Code Code Nr N. Cod.	QTA Qty Qte M.ge C.ad	DENOMINAZIONE	NAME	DESIGNATION	BESCHREIBUNG	DEFINOMACION	Vandrá Vandrá Vandrá Gung Vakoz
	1	1517 94701	1	Estrattore basamento	Crankcase puller	Extracteur carter	Kurbelgehäuse-Auszieher	Extractor cárter	
	2	1519 65301	1	Chiave per esagono incassato	Allen wrench	Clé hexagonale	Sechskanteinsteckschlüssel	Llave de Allen	
	3	1615 13302	1	Estrattore volante	Flywheel extractor	Extracteur pour volant	Auszieher für Schwungrad	Extractor volante	
	4	1519 80501	1	Estratt. ingranaggio lato frizione	Clutch gear puller	Extract. engr. côté embrayage	Auszieher Kupplungszahnrads	Extr. engran. lado fricción	
	5	1515 59101	1	Supporto per montaggio	Support for assy	Support pour montage	Halterung für Montage	Soporte por el montaje	
	6	1514 13401	1	Estrattore braccio oscillante	Swing arm puller	Extract. bras oscillant	Schwingarm-Abzieher	Extractor brazo oscilante	
	7	8000 66802	1	Chiave poliagonale	Poligonal wrench	Clé polygonale	Sechskantschlüssel	Llave poligonal	
	8	1517 94902	1	Attrezzo per volante	Tool for flywheel	Outil pour volant	Vorrichtung für Schwungrad	Herramienta para volante	
	9	8000 91288	1	Introduttore MIM	Jaw	Machoire	Zusatzbacke	Tenaza	
	10	8000 70637	1	Attrezzo mont. albero motore nel carter sinistro	Installing tool. crankshaft left	Outil pour montage vilebrequin dans le demicarter G.	Werkzeug für Montage der Kurbelwelle im L. Gehäuse	Herramienta mont. eje motor en el carter izq.	
	11	8000 39524	1	Chiave di fermo mozzo frizione	Clutch hub retaining wrench	Cléi d'arrêt moyeau embrayage	Halterungsschlüssel der Kupplungsnahe	Llave bloquear cubo fricción	
	12	1519 88201	1	Chiave per nipples	Wrench for nipples	Clé pour nipple	Schlüssel für nipple	Llave para nipple	
	13	1519 84701	1	Gancio per molle	Spring hook	Crochet pour ressort	Federhaken	Gancho para resorte	
	14	8000 91289	1	Attrezzo blocca cartuccia	Pumping retainer	Arrêt pompage	Klammer pumpen	Broche bombeadora	



TE - TE U.S.A.
410 - 610 / 99
TC 610 / 99

TAVOLA
DRAWING
TABLE
BILD
TABLA

2

TESTA, CILINDRO - CYLINDER HEAD, CYLINDER
CULASSE, CYLINDRE - ZYLINDERKOPF, ZYLINDER
CULATA, CILINDRO

Note Notes Markas Notas	Pos. No N Index Pos.	N. Cod. Code No. Nr. Code Code Nr N. Cod.	QIA Qty Qte M qe C ad	DE NOMINAZIONE	NAME	DESIGNATION	BE SCHRIBUNG	DE NOMINACION	VARRA VARRA VARRA GUNG VARRA
	1	61N1 15195	2	Dado	Nut	Ecrou	Mutter	Tuerca	
	2	1615 40702	1	Guarnizione	Gasket	Garnitue	Dichtung	Junta	
	3	1615 35801	1	Guarnizione	Gasket	Garnitue	Dichtung	Junta	
	4	1615 33201	2	Prigioniero	Stud bolt	Prisonnier	Stiftschraube	Prisionero	
	5	8000 64726	1	Guarnizione (610)	Gasket (610)	Garnitue (610)	Dichtung (610)	Junta (610)	
	5	1615 36001	1	Guarnizione (410)	Gasket (410)	Garnitue (410)	Dichtung (410)	Junta (410)	
	6	8000 67744	1	Tenditore	Tensioner	Tendeur	Zylinderspanner	Tensor	
	7	8000 66428	2	Valvola scarico (610)	Exhaust valve (610)	Soupape d'échappement (610)	Auslass-Ventil (610)	Válvula de escape (610)	
	7	8000 68589	2	Valvola scarico (410)	Exhaust valve (410)	Soupape d'échappement (410)	Auslass-Ventil (410)	Válvula de escape (410)	
	8	1611 70801	2	Bussola	Bushing	Douille	Buchse	Manguito	
	9	8000 63817	1	Bussola	Bushing	Douille	Buchse	Manguito	
	10	1615 29401	4	Guidavalvola	Valve guide	Guide-soupape	Ventilführung	Guía-válvula	
	11	1615 28801	4	Molla interna	Spring	Ressort	Feder	Resorte	
	12	1615 02501	4	Molla esterna	Spring	Ressort	Feder	Resorte	
	13	1615 29601	4	Scodellino	Cup	Cuvette	Teller	Cubeta	
	14	1615 02301	8	Semicono	Half cone	Demi-cône	Halb Kegel	Semi-cono	
	15	1615 35101	4	Dado	Nut	Ecrou	Mutter	Tuerca	
	16	1615 23801	1	Raccordo (610)	Union (610)	Raccord (610)	Anschluss (610)	Empalme (610)	
	16	8A00 63649	1	Raccordo (410)	Union (410)	Raccord (410)	Anschluss (410)	Empalme (410)	
A	17	1615 30301	4	Anello di tenuta GÖTZE	Seal ring GÖTZE	Bague d'étanchéité GÖTZE	Dichtungsring GÖTZE	Anillo de retención GÖTZE	
A	17	8000 75584	4	Anello di tenuta CORCOS	Seal ring CORCOS	Bague d'étanchéité CORCOS	Dichtungsring CORCOS	Anillo de retención CORCOS	
	18	1615 35902	1	Vite	Screw	Vis	Schraube	Tornillo	
	19	8000 68905	1	Distanziale (610)	Spacer (610)	Entretoise (610)	Distanzstück (610)	Separador (610)	
	20	8000 47708	2	Spina elastica	Pin	Goupille	Stift	Clavija	
	21	8000 42278	1	Dado	Nut	Ecrou	Mutter	Tuerca	
	22	60N1 07335	2	Vite	Screw	Vis	Schraube	Tornillo	
	23	8000 68908	1	Tenditore completo (610)	Complete tensioner (610)	Tendeur complet (610)	Zylinderspanner (610)	Tensor completo (610)	
	24	80B0 75766	1	Corpo pompa	Pump body	Corps pompe	Pumpenkörper	Corpo bomba	
	25	8000 66807	1	Pattino catena	Chain slider	Glissière	Gleitbahn	Plato cadena	
	26	8000 45194	1	Rosetta piana	Washer	Rondelle	Scheibe	Arandela	
	27	8000 66427	2	Valvola aspirazione (610)	Inlet valve (610)	Soupape admission (610)	Einlass-Ventil (610)	Válvula aspiración (610)	
	27	8000 68590	2	Valvola aspirazione (410)	Inlet valve (410)	Soupape admission (410)	Einlass-Ventil (410)	Válvula aspiración (410)	

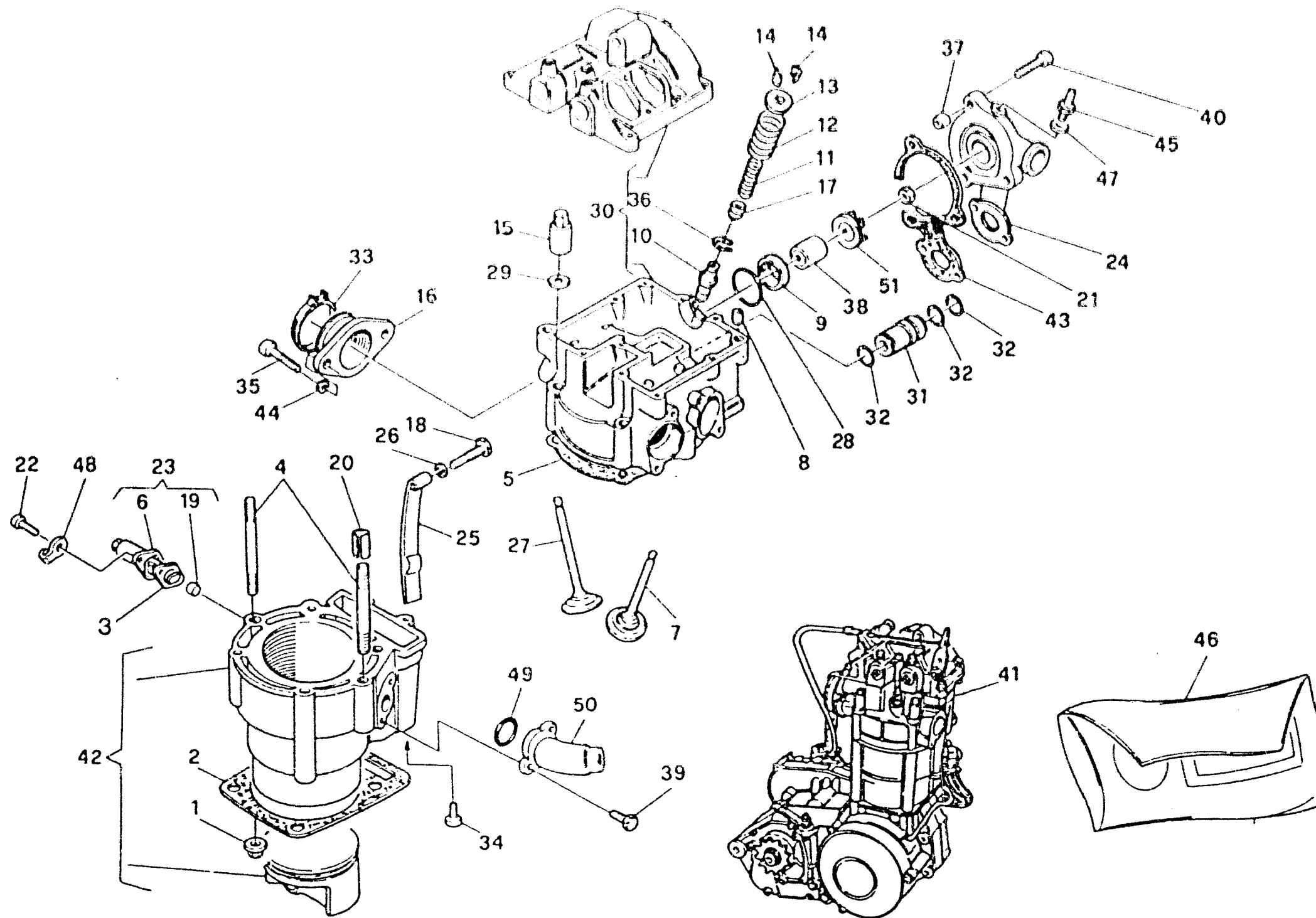



TE - TE U.S.A.
410 - 610 / 99
TC 610 / 99

TAVOLA
DRAWING
TABLE
BILD
TABLA

2

TESTA, CILINDRO - CYLINDER HEAD, CYLINDER
CULASSE, CYLINDRE - ZYLINDERKOPF, ZYLINDER
CULATA, CILINDRO

Notes Notes Marka Notes	Pos No N Index Pos	N. Cod Code No Nr. Code Code No N. Cod.	Q ta Q ty Q te M ge C ad	DE NOMINAZIONE	NAME	DESIGNATION	BESCHREIBUNG	DE NOMINACION	Vandaa Vandaa Gullig Vandaa
	28	8000 56342	1	Anello OR	O-Ring	Bague OR	O-Ring	Anillo OR	
	29	8000 69156	4	Rosetta piana	Washer	Rondelle	Scheibe	Arandela	
	30	8B00 78437	1	Coperchio e testa (610)	Cover and head (610)	Couvercle et culasse (610)	Dekel und Zylinderkopf (610)	Tapa e culata (610)	
	30	8A00 85355	1	Coperchio e testa (410)	Cover and head (410)	Couvercle et culasse (410)	Dekel und Zylinderkopf (410)	Tapa e culata (410)	
	31	8A00 78765	1	Tubetto	Pipe	Tuyau	Rohr	Tubo	
	32	8000 18422	3	Anello OR	O-Ring	Bague OR	O-Ring	Anillo OR	
	33	8000 60558	1	Fascetta	Clamp	Collier	Schelle	Banda	
	34	60N1 02510	2	Vite	Screw	Vis	Schraube	Tornillo	
	35	60N1 02557	2	Vite	Screw	Vis	Schraube	Tornillo	
	36	8000 59940	4	Anello di arresto	Snap ring	Bague d'arrêt	Haltering	Anillo elástico de retención	
	37	1617 95501	2	Bussola	Bushing	Douille	Buchse	Manguito	
	38	8000 53339	1	Anello di tenuta	Seal ring	Bague d'étanchéité	Dichtungsring	Anillo de retención	
	39	8000 62727	2	Vite	Screw	Vis	Schraube	Tornillo	
	40	8000 62730	5	Vite	Screw	Vis	Schraube	Tornillo	
W	41	8000 89905	1	Assieme motore (610)	Engine assy (610)	Moteur complet (610)	Motor kpl. (610)	Motor compl. (610)	
U	41	8000 90648	1	Assieme motore (610)	Engine assy (610)	Moteur complet (610)	Motor kpl. (610)	Motor compl. (610)	
W	41	8000 90061	1	Assieme motore (410)	Engine assy (410)	Moteur complet (410)	Motor kpl. (410)	Motor compl. (410)	
U	41	8000 90601	1	Assieme motore (410)	Engine assy (410)	Moteur complet (410)	Motor kpl. (410)	Motor compl. (410)	
C	41	8000 90058	1	Assieme motore (610)	Engine assy (610)	Moteur complet (610)	Motor kpl. (610)	Motor compl. (610)	
A	42	8000 89910	1	Cilindro completo (610)	Cylinder assy (610)	Cylindre compl. (610)	Zylinder kpl. (610)	Cilindro compl. (610)	
A	42	8000 90050	1	Cilindro completo (ASSO) (610)	Cylinder assy (ASSO) (610)	Cylindre compl. (ASSO) (610)	Zylinder kpl. (ASSO) (610)	Cilindro compl. (ASSO) (610)	
	42	8000 90064	1	Cilindro completo (410)	Cylinder assy (410)	Cylindre compl. (410)	Zylinder kpl. (410)	Cilindro compl. (410)	
	43	8A00 63644	1	Guarnizione	Gasket	Garniture	Dichtung	Junta	
	44	8000 08536	2	Rosetta piana	Washer	Rondelle	Scheibe	Arandela	
	45	8000 66395	1	Raccordo	Union	Raccord	Anschluss	Empalme	
R	46	8000 90055	1	Gruppo guarnizioni motore (610)	Gasket set (610)	Groupe garnitures (610)	Dichtungssatz (610)	Grupo juntas (610)	
R	46	8000 90183	1	Gruppo guarnizioni motore (410)	Gasket set (410)	Groupe garnitures (410)	Dichtungssatz (410)	Grupo juntas (410)	
	47	8A00 15960	1	Rosetta	Washer	Rondelle	Scheibe	Arandela	
	48	8000 24319	1	Piastrina	Plate	Plaquette	Plättchen	Placa	
	49	8000 19789	1	Anello OR	O-Ring	Bague OR	O-Ring	Anillo OR	
	50	80A0 66222	1	Raccordo	Union	Raccord	Anschluss	Empalme	
	51	8A00 60415	1	Girante	Rotor	Couronne	Laufrad	Rotor	

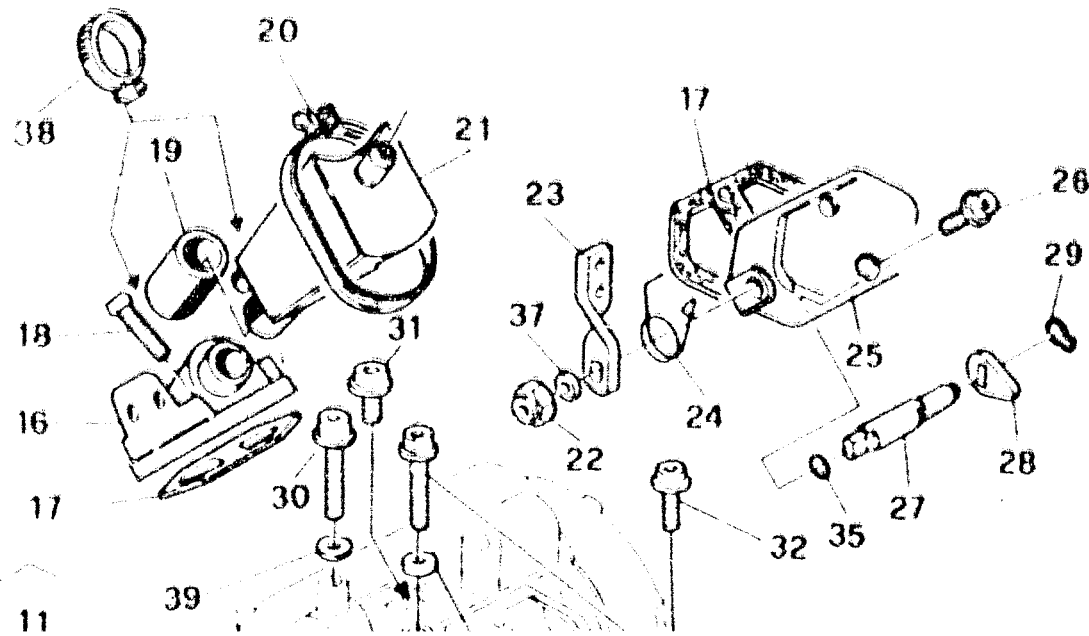



TE · TE U.S.A.
410 - 610 / 99
TC 610 / 99

TAVOLA
DRAWING
TABLE
BILD
TABLA

3

DISTRIBUZIONE · VALVE TIMING
DISTRIBUTION · VENTILSTEUERUNG
DISTRIBUCION

Note Notes Notas	Pos No N	N. Cod. Code No Nr. Code Code Nr N. Cod.	Q'tà Qty Q'te Mtg G ad	DENOMINAZIONE	NAME	DESIGNATION	BESCHREIBUNG	DE NOMINACION	Venda Vendy Vendá Gung Vender
	1	8000 02124	2	Cuscinetti	Bearing	Roulement	Lager	Cojinete	
WU	2	8000 73150	1	Albero a camme (610)	Camshaft (610)	Arbre distribution (610)	Nockenwelle (610)	Eje distribución (610)	
WU	2	8000 85378	1	Albero a camme (410)	Camshaft (410)	Arbre distribution (410)	Nockenwelle (410)	Eje distribución (410)	
C	2	8000 75780	1	Albero a camme (610)	Camshaft (610)	Arbre distribution (610)	Nockenwelle (610)	Eje distribución (610)	
	3	8000 71028	1	Ingranaggio condotto (610)	Driven gear (610)	Engrainage conduit (610)	Zahnrad (610)	Engranaje conducto (610)	
	3	8000 76461	1	Ingranaggio condotto (410)	Driven gear (410)	Engrainage conduit (410)	Zahnrad (410)	Engranaje conducto (410)	
	4	1615 26602	2	Vite	Screw	Vis	Schraube	Tornillo	
	5	8A00 35794	1	Catena distribuzione (610)	Chain (610)	Chaîne (610)	Kette (610)	Cadena (610)	
	5	8B00 35794	1	Catena distribuzione (410)	Chain (410)	Chaîne (410)	Kette (410)	Cadena (410)	
	6	62N1 15658	2	Rosetta elastica	Spring washer	Rondelle élastique	Federscheibe	Arandela elástica	
	7	1615 04901	4	Vite di registro	Adjusting screw	Vis de réglage	Verstellungsschraube	Tornillo de regulación	
	8	1615 04301	4	Bussola	Bushing	Douille	Buchse	Manguito	
	9	1615 09601	1	Bilancere di scarico completo	Exhaust rocker-arm assy	Culbuteur échappement compl.	Kipphebel Auspuffrohr kpl.	Balancin de escape compl.	
	10	1615 15601	4	Dado	Nut	Ecrou	Mutter	Tuerca	
	11	1615 04501	2	Cuscinetto a rullini	Needle bearing	Roulement à aiguilles	Nadelkäfig	Cojinete de rodillos	
	12	1615 09501	1	Bilancere di aspirazione compl.	Inlet rocker-arm assy	Culbuteur d'aspiration compl.	Kipphebel Ansaugen kpl.	Balancin de aspiración compl.	
	13	1615 04201	2	Perno	Pin	Pivot	Boizen	Perno	
	14	8000 59939	2	Anello OR	O-Ring	Bague OR	O-Ring	Anillo OR	
	15	1615 33301	2	Tappo	Plug	Bouchon	Verschluss	Tapón	
	16	80B0 84174	1	Coperchio registri	Cover	Couvercle	Deckel	Tapa	
	17	1615 03601	2	Guarnizione	Gasket	Garniture	Dichtung	Junta	
	18	8000 62728	3	Vite	Screw	Vis	Schraube	Tornillo	
	19	1615 14104	1	Tubetto	Tube	Tuyau	Rohr	Tubo	
	20	8000 37299	1	Fascetta	Clamp	Collier	Schelle	Banda	
	21	1615 12802	1	Contenitore vapori basamento	Crankcase vapours cup	Cuve vapeurs carter	Dampfgefäß im Kurbelgehäuse	Contenedor vapores cárter	
	22	61N1 15195	1	Dado	Nut	Ecrou	Mutter	Tuerca	
	23	1615 40802	1	Leva	Lever	Levier	Hebel	Palanca	
	24	1615 12301	1	Molla	Spring	Ressort	Feder	Resorte	
	25	80B0 84173	1	Coperchio decompressore	Cover	Couvercle	Deckel	Tapa	
	26	8E00 67545	1	Vite	Screw	Vis	Schraube	Tornillo	
	27	1615 08401	1	Perno	Pin	Pivot	Boizen	Perno	
	28	1615 08501	1	Camma decompressore	Cam	Came	Nocken	Excéntrico	

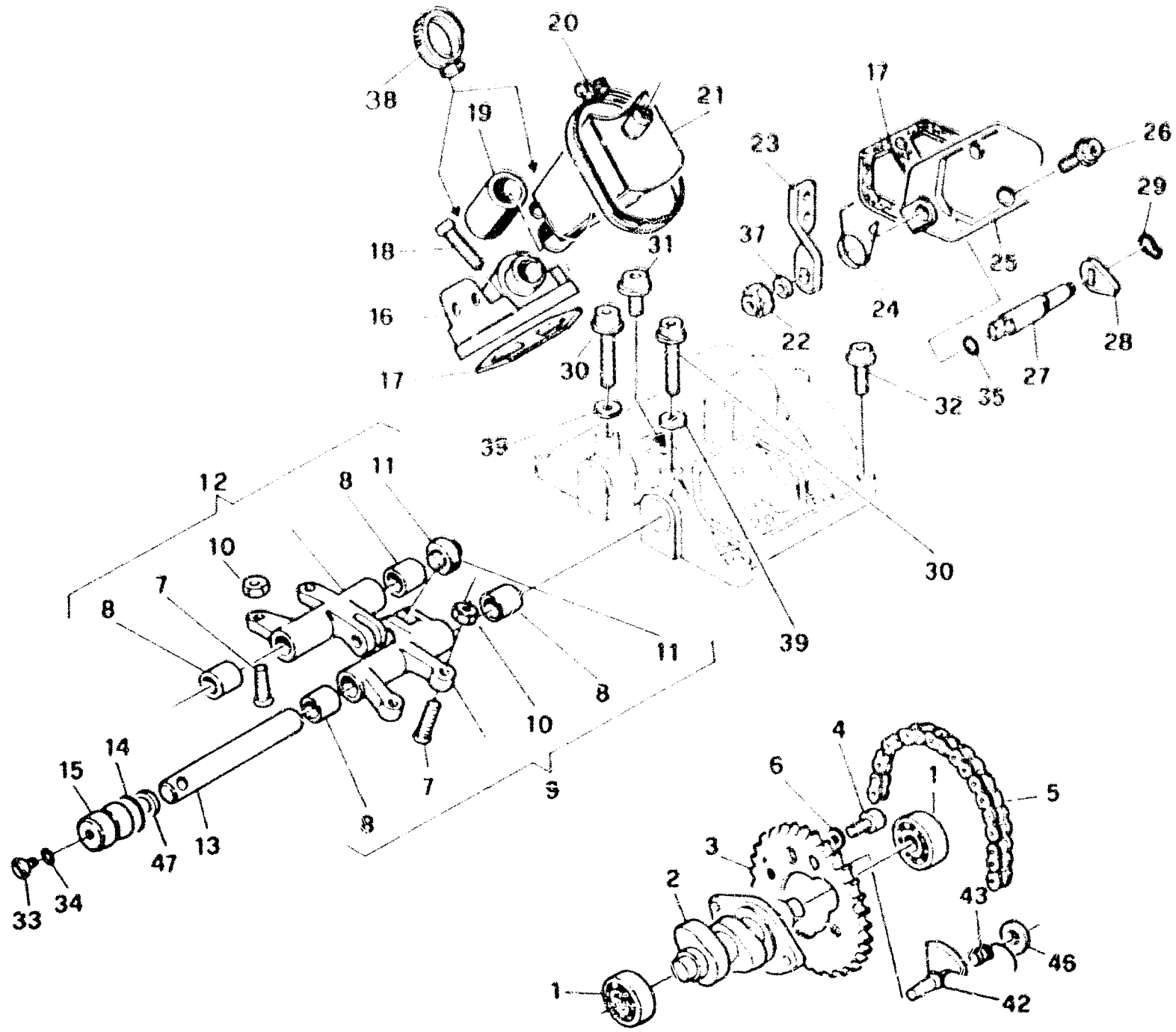



TE - TE U.S.A.
410 - 610 / 99
TC 610 / 99

TAVOLA
DRAWING
TABLE
BILD
TABLA



DISTRIBUZIONE - VALVE TIMING
DISTRIBUTION - VENTILSTEUERUNG
DISTRIBUCION

Note Notes Notas	Pos No Index Pos	N. Cod. Code No Nr. Code Code Nr N. Cod	Q.tà Qty Q.te M. ga C. ad	DE NOMINAZIONE	NAME	DESIGNATION	BESCHREIBUNG	DE NOMINACION	Vas. 102 Vas. 104 Vas. 106 G. 108 Vas. 109
	29	8000 21375	1	Anello di fermo	Stop ring	Bague d'arrêt	Haltering	Anillo de retención	
	30	8000 67545	2	Vite	Screw	Vis	Schraube	Tornillo	
	31	8000 62731	1	Vite	Screw	Vis	Schraube	Tornillo	
	32	8000 62730	8	Vite	Screw	Vis	Schraube	Tornillo	
	33	60N1 02927	2	Vite	Screw	Vis	Schraube	Tornillo	
	34	8A00 15960	2	Rosetta piana	Washer	Rondelle	Scheibe	Arandela	
	35	8000 59941	1	Anello OR	O-Ring	Bague OR	O-Ring	Anillo OR	
	37	62N1 15567	1	Rosetta piana	Washer	Rondelle	Scheibe	Arandela	
	38	8000 46881	2	Fascetta	Clamp	Collier	Schelle	Banda	
	39	8000 64988	2	Rosetta	Washer	Rondelle	Scheibe	Arandela	
	42	8000 72289	1	Alzavalvola (610)	Valve lifter (610)	Levée de soupape (610)	Ventilauflheber (610)	Alza valvula (610)	
	42	8A00 72289	1	Alzavalvola (410)	Valve lifter (410)	Levée de soupape (410)	Ventilauflheber (410)	Alza valvula (410)	
	43	8000 72290	1	Molla	Spring	Ressort	Feder	Resorte	
	46	8F00 10789	1	Rosetta	Washer	Rondelle	Scheibe	Arandela	
	47	8000 50322	2	Rosetta di rasamento Sp. 0,3	Washer	Rondelle	Scheibe	Arandela	
	47	8A00 50322	2	Rosetta di rasamento Sp. 0,4	Washer	Rondelle	Scheibe	Arandela	
	47	8B00 50322	2	Rosetta di rasamento Sp. 0,5	Washer	Rondelle	Scheibe	Arandela	
	47	8C00 50322	2	Rosetta di rasamento Sp. 0,6	Washer	Rondelle	Scheibe	Arandela	

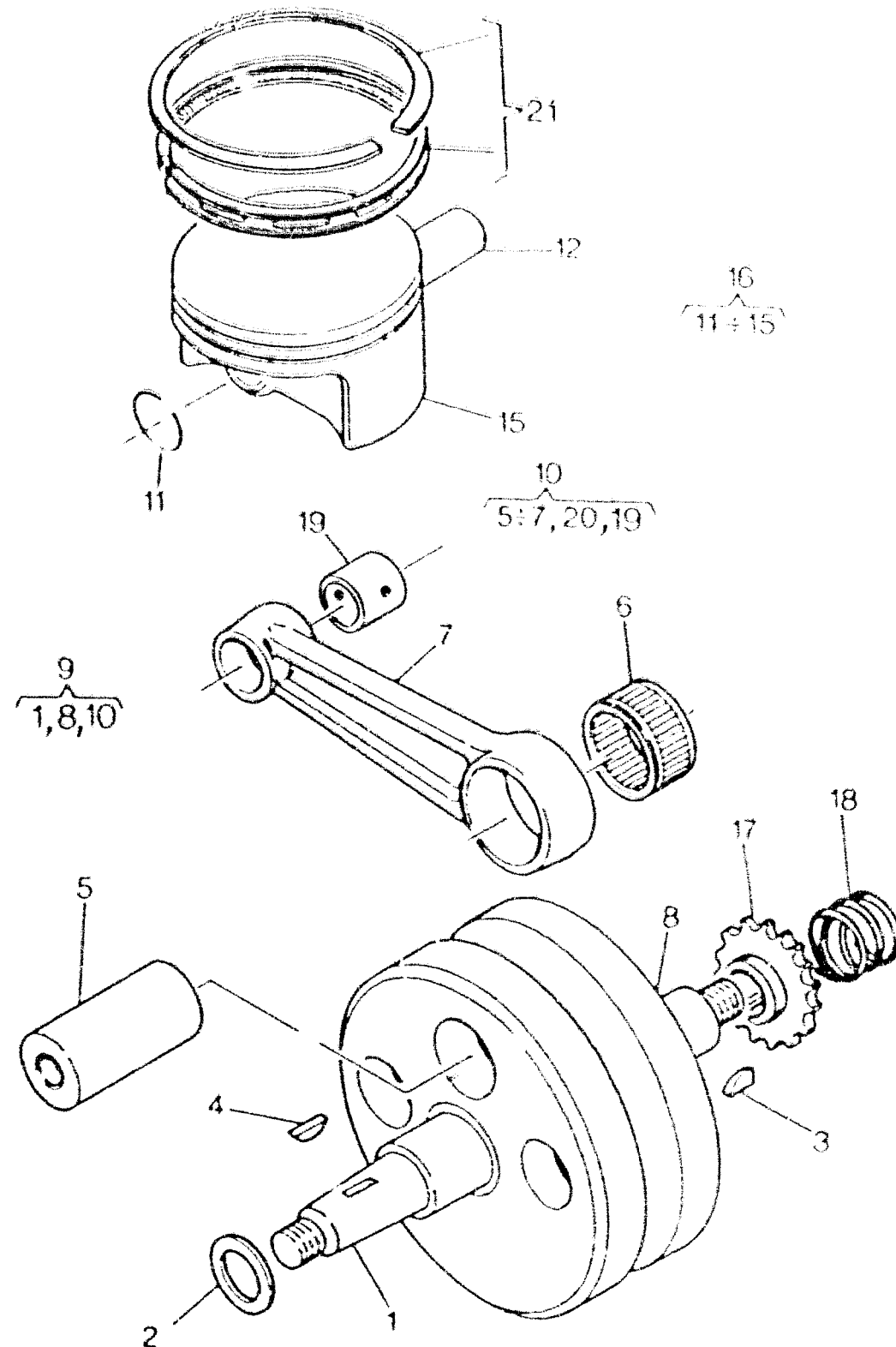



TE - TE U.S.A.
410 - 610 / 99
TC 610 / 99

TAVOLA
DRAWING
TABLE
BILD
TABLA

4

PISTONE, MANOVELLISMO - PISTON, CRANKSHAFT
PISTON, VILEBREQUIN - KOLBEN, KURBELWELLE
PISTON, PALANÇAS

Notes Notas Marka Notas	Pos. N. Index Pos.	N. Cod. Code No. Nr. Code Code Nr. N. Cod.	Q.tà Qty Q.té Mtg C.ad	DENOMINAZIONE	NAME	DESIGNATION	RESERVE PARTS	DENOMINAZIONE
	2	8A00 28183	1	Rosetta di rasamento Sp. 0,3	Washer	Rondelle	Scheibe	Arandela
	2	8C00 28183	1	Rosetta di rasamento Sp. 0,5	Washer	Rondelle	Scheibe	Arandela
	2	8D00 28183	1	Rosetta di rasamento Sp. 0,6	Washer	Rondelle	Scheibe	Arandela
	2	8F00 28183	1	Rosetta di rasamento Sp. 0,8	Washer	Rondelle	Scheibe	Arandela
	2	8H00 28183	1	Rosetta di rasamento Sp. 1,0	Washer	Rondelle	Scheibe	Arandela
	3	1615 09801	1	Linguetta	Woodruff key	Clé woodruff	Federkeil	Lengueta
	4	1513 71301	1	Linguetta	Woodruff key	Clé woodruff	Federkeil	Lengueta
	9	8000 89897	1	Albero motore completo (610)	Crankshaft assy (610)	Vilebrequin compl. (610)	Kurbwelle kpl. (610)	Cigüeñal compl. (610)
	9	8000 90171	1	Albero motore completo (410)	Crankshaft assy (410)	Vilebrequin compl. (410)	Kurbwelle kpl. (410)	Cigüeñal compl. (410)
	10	8000 89895	1	Biella completa (610)	Connecting rod compl. (610)	Bielle compl. (610)	Pleuelstange kpl. (610)	Biela motor completa (610)
	10	8000 90172	1	Biella completa (410)	Connecting rod compl. (410)	Bielle compl. (410)	Pleuelstange kpl. (410)	Biela motor completa (410)
	11	8000 67824	2	Anello di fermo (610)	Stop ring (610)	Bague d'arrêt (610)	Haltering (610)	Anillo de retención (610)
	11	1615 35501	2	Anello di fermo (410)	Stop ring (410)	Bague d'arrêt (410)	Haltering (410)	Anillo de retención (410)
	12	8000 71787	1	Spinotto (610)	Gudgeon (610)	Axe (610)	Bolzen (610)	Perno (610)
	12	1615 37001	1	Spinotto (410)	Gudgeon (410)	Axe (410)	Bolzen (410)	Perno (410)
A	16	8000 89908	1	Pistone completo Ø 98 (610)	Compl. piston (610)	Piston complet (610)	Kolbe, kpl. (610)	Pistón completo (610)
A	16	8000 85243	1	Pistone compl. Ø 98 (ASSO) (610)	Compl. piston (610)	Piston complet (610)	Kolbe, kpl. (610)	Pistón completo (610)
A	16	8000 90671	1	Pistone completo Ø 91,5 (410)	Compl. piston (410)	Piston complet (410)	Kolbe, kpl. (410)	Pistón completo (410)
A	16	8000 90065	1	Pistone compl. Ø 91,5 (ASSO) (410)	Compl. piston (410)	Piston complet (410)	Kolbe, kpl. (410)	Pistón completo (410)
	17	8C00 71027	1	Ingranaggio distribuzione (610)	Gear (610)	Engranage (610)	Zahnrad (610)	Engranaje (610)
	17	8C00 63811	1	Ingranaggio distribuzione (410)	Gear (410)	Engranage (410)	Zahnrad (410)	Engranaje (410)
	18	8000 61275	1	Molla	Spring	Ressort	Feder	Resorte
	19	8000 88073	1	Bussola (610)	Bushing (610)	Douille (610)	Buchse (610)	Manguito (610)
	19	8000 59539	1	Bussola (410)	Bushing (410)	Douille (410)	Buchse (410)	Manguito (410)
	21	8000 77715	1	Kit segmenti (610)	Circlip kit (610)	Kit segment (610)	Kolbenring kit (610)	Kit segmento (610)
	21	8000 30101	1	Kit segmenti (410)	Circlip kit (410)	Kit segment (410)	Kolbenring kit (410)	Kit segmento (410)

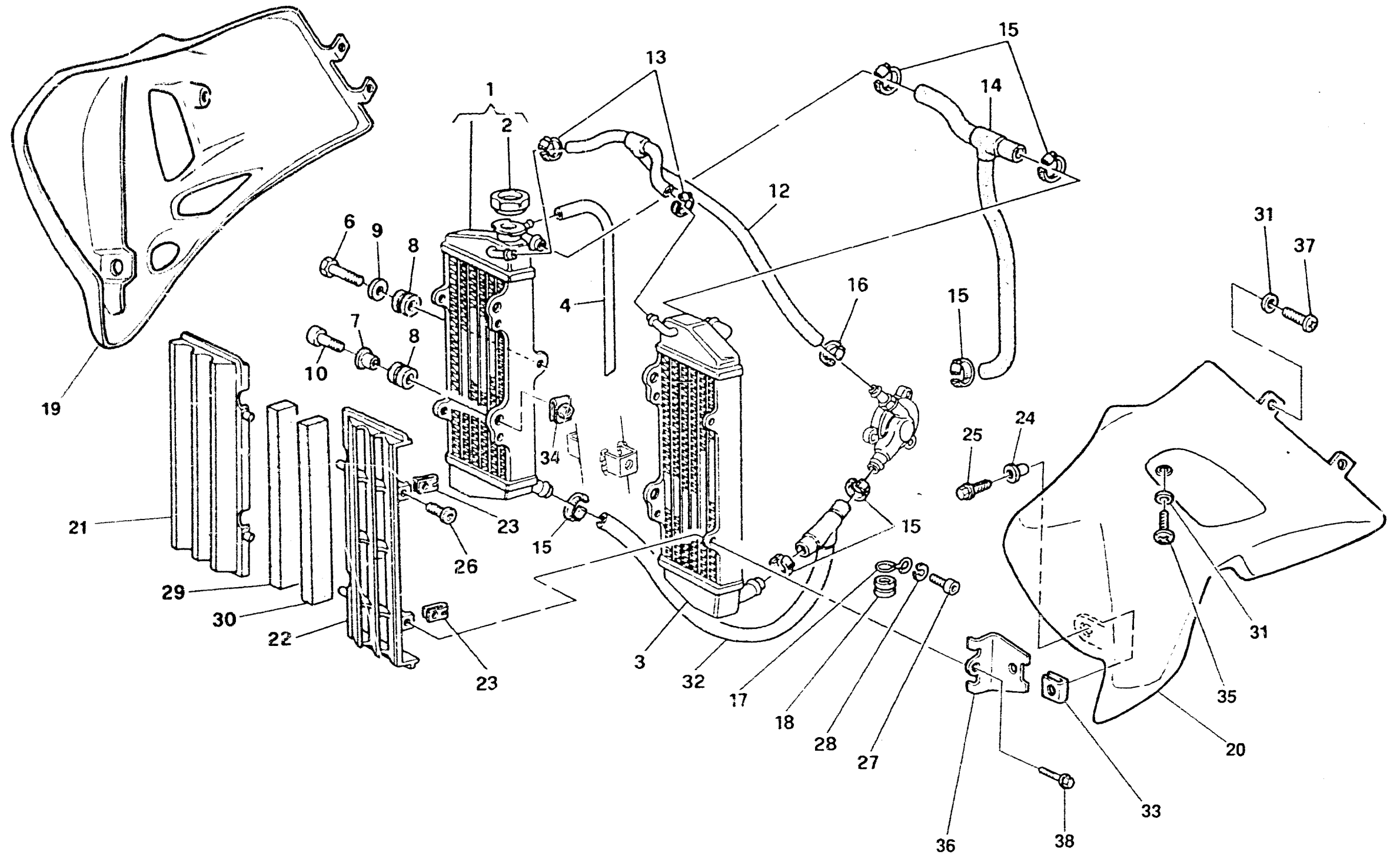



TE - TE U.S.A.
410 - 610 / 99
TC 610 / 99

TAVOLA
DRAWING
TABLE
BILD
TABLA

5

RAFFREDDAMENTO - COOLING
REFROIDISSEMENT - WASSERKÜHLUNG
ENFRIAMIENTO

Note Notes Marka Notas	Pos. No. N. Index Pos.	N. Cod. Code No. Nr. Code Code Nr N. Cod.	Q.tà Q.ty Q.te M.ge C.ad	DENOMINAZIONE	NAME	DESIGNATION	BESHREIBUNG	DENOMINACION	Validità Validity Valiété Gültig Validez
	1	80A0 67186	1	Radiatore Dx. completo	R.H. radiator compl.	Radiateur D. compl.	R., Kühler kpl.	Radiador derech. compl.	
	2	8000 43714	1	Tappo	Plug	Bouchon	Verschluss	Tapón	
	3	80A0 66800	1	Radiatore Sx.	L.H. radiator	Radiateur G.	L., Kühler	Radiador izrdo.	
	4	8000 43715	1	Tubetto sfiato	Tube	Tuyau	Rohr	Tubo	
	6	8000 62725	2	Vite	Screw	Vis	Schraube	Tomillo	
	7	8000 59802	2	Bussola	Bushing	Douille	Buchse	Manguito	
	8	8000 59803	4	Gommino	Rubber pad	Pièce caoutchouc	Gummistück	Junta de goma	
	9	8000 59801	2	Rosetta piana	Washer	Rondelle	Scheibe	Arandela	
	10	8000 62728	2	Vite	Screw	Vis	Schraube	Tomillo	
	12	8000 66850	1	Tubo	Pipe	Tuyau	Schlauch	Tubo	
	13	8000 57242	2	Fascetta	Clamp	Collier	Schelle	Banda	
	14	8000 66851	1	Tubo cilindro radiatori	Pipe	Tuyau	Schlauch	Tubo	
	15	8000 68666	6	Fascetta	Clamp	Collier	Schelle	Banda	
	16	8000 67610	1	Fascetta	Clamp	Collier	Schelle	Banda	
	17	8000 87859	1	Anello di guida	Ring	Bague	Ring	Anillo	
	18	8000 67449	1	Gommino	Rubber pad	Pièce caoutchouc	Gummistück	Junta de goma	
	19	80F0 87061	1	Convogliatore Dx.	Right side panel	Flanc droit	Rechte Flanke	Lateral derecho	
	20	80F0 87062	1	Convogliatore Sx.	Left side panel	Flanc gauche	Linke Flanke	Lateral izquierdo	
	21	80A0 67248	2	Griglia	Grille	Grille	Gitter	Panilla	
	23	8000 60873	4	Dado a graffetta	Nut	Ecrou	Mutter	Tuerca	
	24	8000 76069	2	Boccola	Bush	Douille	Buchse	Casquillo	
	25	8000 62729	2	Vite	Screw	Vis	Schraube	Tomillo	
	26	8000 62725	2	Vite	Screw	Vis	Schraube	Tomillo	
	27	8000 62725	1	Vite	Screw	Vis	Schraube	Tomillo	
	28	62N1 15519	1	Rosetta piana	Washer	Rondelle	Scheibe	Arandela	
	29	3000 60925	1	Spessore	Spacer	Entretoise	Distanzstück	Separador	
	30	3000 60925	1	Spessore	Spacer	Entretoise	Distanzstück	Separador	
	31	8000 45495	6	Rosetta	Washer	Rondelle	Scheibe	Arandela	
	32	8A00 72284	1	Ass. tubo	Pipe	Tuyau	Schlauch	Tubo	
	33	8000 46893	2	Dado a graffetta	Nut	Ecrou	Mutter	Tuerca	
	34	8000 46893	2	Dado a graffetta	Nut	Ecrou	Mutter	Tuerca	
	35	8000 62725	2	Vite	Screw	Vis	Schraube	Tomillo	

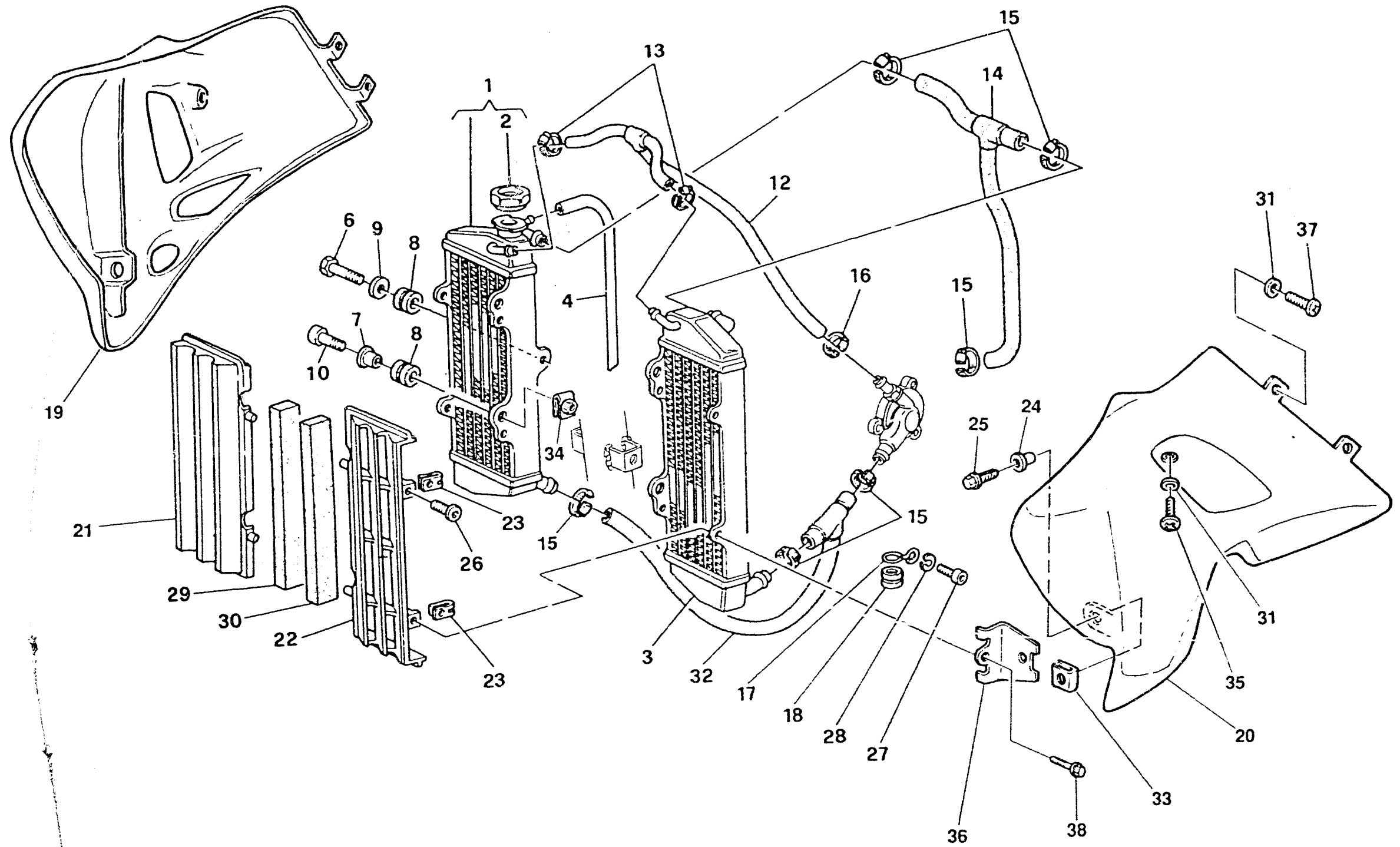



TE - TE U.S.A.
410 - 610 / 99
TC 610 / 99

TAVOLA
DRAWING
TABLE
BILD
TABLA

5

RAFFREDDAMENTO - COOLING
REFROIDISSEMENT - WASSERKÜHLUNG
ENFRIAMIENTO

Note Notes Mark Notas	Pos. No. N. Index Pos.	N. Cod. Code No. Nr. Code Code Nr N. Cod.	Q.tà Q.ty Q.té M.ge C.ad	DENOMINAZIONE	NAME	DESIGNATION	BESHREIBUNG	DENOMINACION	Validità Validity Validité Gültig Validez
	36	8000 87127	1	Piastrina.	Plate	Plaque	Platte	Placa	
	37	8000 36467	4	Vite	Screw	Vis	Schraube	Tornillo	
	38	8000 62726	2	Vite	Screw	Vis	Schraube	Tornillo	

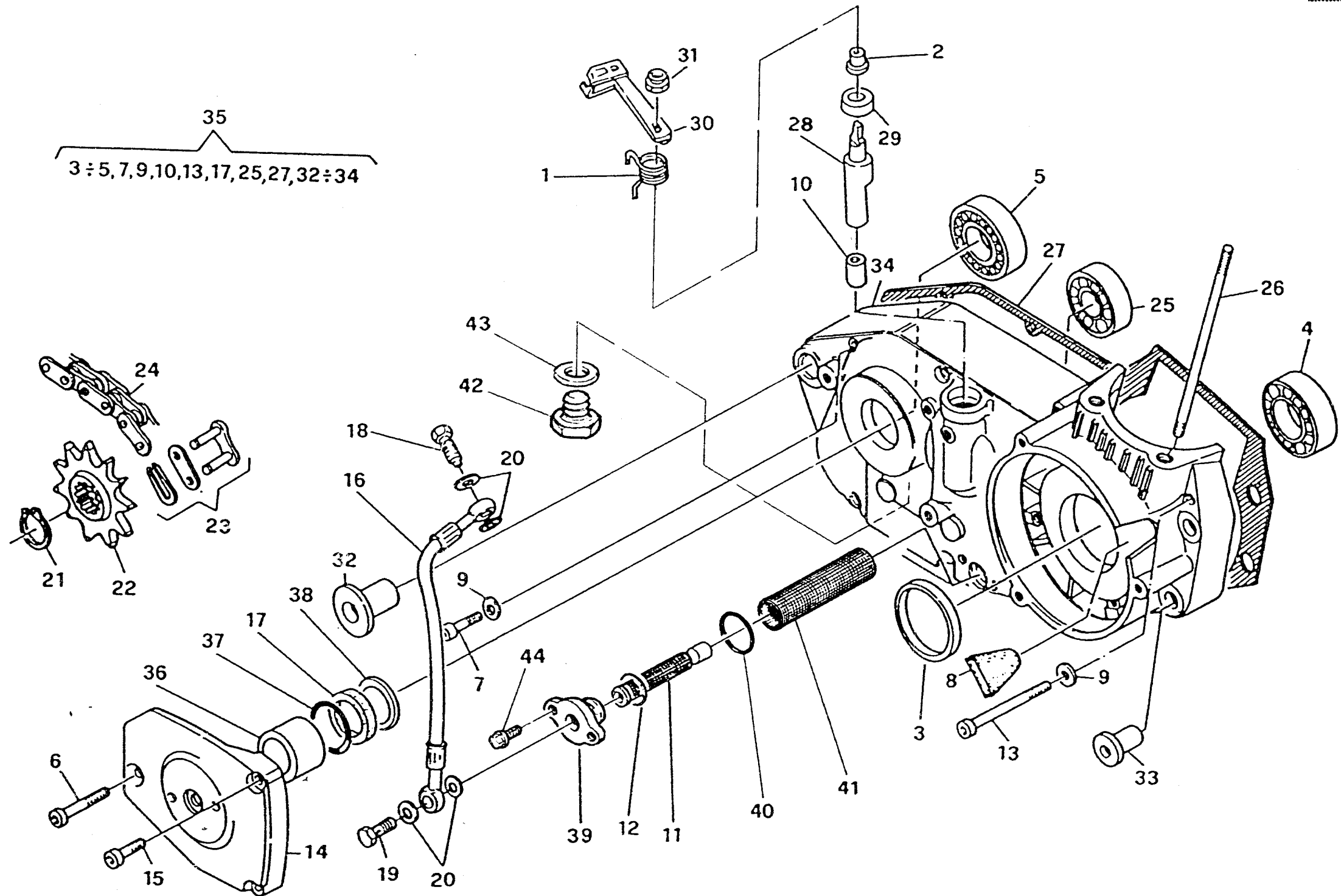



TE - TE U.S.A.
410 - 610 / 99
TC 610 / 99

TAVOLA
DRAWING
TABLE
BILD
TABLA

6

SEMICARTER DESTRO - R.H. HALF CRANKCASE
CARTER D. - GEHAUSEDECKEL R.
BANCADA DER.

Note Notes Marka Notas	Pos. No. N. Index Pos.	N. Cod. Code No. Nr. Code Code Nr N. Cod.	Q.tà Q.ty Q.te M.ge C.ad	DENOMINAZIONE	NAME	DESIGNATION	BESHREIBUNG	DENOMINACION	Validità Validty Valdré Gültig Validez
	1	8A00 48188	1	Molla	Spring	Ressort	Feder	Resorte	
	2	8A00 55532	1	Bussola	Bushing	Douille	Buchse	Manguito	
	3	1513 72602	1	Anello di tenuta	Seal ring	Bague d'étanchéité	Dichtungsring	Anillo de retención	
	4	8000 28182	1	Cuscinetto	Bearing	Roulement	Lager	Cojinete	
	5	8000 43789	1	Cuscinetto	Bearing	Roulement	Lager	Cojinete	
	6	60N1 02513	1	Vite	Screw	Vis	Schraube	Tomillo	
	7	60N1 02520	6	Vite	Screw	Vis	Schraube	Tomillo	
	8	1614 72801	1	Gommino	Rubber pad	Pièce caoutchouc	Gummistück	Junta de goma	
	9	62N1 15504	8	Rosetta piana	Washer	Rondelle	Scheibe	Arandela	
	10	8000 68195	1	Bussola	Bushing	Douille	Buchse	Manguito	
	11	8000 72427	1	Filtro olio interno	Internal oil filter	Filtre à huile	Ölfilter	Filtro aceite	
	12	8000 26884	1	Anello di tenuta	Seal ring	Bague d'étanchéité	Dichtungsring	Anillo de retención	
	13	60N1 02515	2	Vite	Screw	Vis	Schraube	Tomillo	
	14	1611 81604	1	Coperchio	Cover	Couvercle	Deckel	Tapa	
	15	60N1 02510	2	Vite	Screw	Vis	Schraube	Tomillo	
	16	8000 65653	1	Tubo	Pipe	Tuyau	Schlauch	Tubo	
	17	8000 59977	1	Anello di tenuta	Seal ring	Bague d'étanchéité	Dichtungsring	Anillo de retención	
	18	8000 91743	1	Vite (610)	Screw (610)	Vis (610)	Schraube (610)	Tomillo (610)	
	18	8000 66281	1	Vite (410)	Screw (410)	Vis (410)	Schraube (410)	Tomillo (410)	
	19	8000 45183	1	Vite	Screw	Vis	Schraube	Tomillo	
	20	8000 21480	4	Rosetta	Washer	Rondelle	Scheibe	Arandela	
	21	66N0 21211	1	Anello di fermo	Stop ring	Bague d'arrêt	Haltering	Anillo de retención	
W	22	8000 63832	1	Pignone Z=17 (610)	Pinion Z=17 (610)	Pignon Z=17 (610)	Ritzel Z=17 (610)	Piñón Z=17 (610)	
W	22	8000 63830	1	Pignone Z=15 (410)	Pinion Z=15 (410)	Pignon Z=15 (410)	Ritzel Z=15 (410)	Piñón Z=15 (410)	
U	22	8000 63827	1	Pignone Z=12 (410)	Pinion Z=12 (410)	Pignon Z=12 (410)	Ritzel Z=12 (410)	Piñón Z=12 (410)	
UC	22	8000 63829	1	Pignone Z=14 (610)	Pinion Z=14 (610)	Pignon Z=14 (610)	Ritzel Z=14 (610)	Piñón Z=14 (610)	
WD	22	8000 63829	1	Pignone Z=14 (610)	Pinion Z=14 (610)	Pignon Z=14 (610)	Ritzel Z=14 (610)	Piñón Z=14 (610)	
WD	22	8000 63827	1	Pignone Z=12 (410)	Pinion Z=12 (410)	Pignon Z=12 (410)	Ritzel Z=12 (410)	Piñón Z=12 (410)	
WUA	23	8000 65464	1	Giunto per catena Regina	Coupling	Joint	Kupplung	Junta	
WUA	23	8000 79789	1	Giunto per catena DID	Coupling	Joint	Kupplung	Junta	
CA	23	8000 56767	1	Giunto per catena Regina	Coupling	Joint	Kupplung	Junta	
CA	23	8000 79790	1	Giunto per catena DID	Coupling	Joint	Kupplung	Junta	

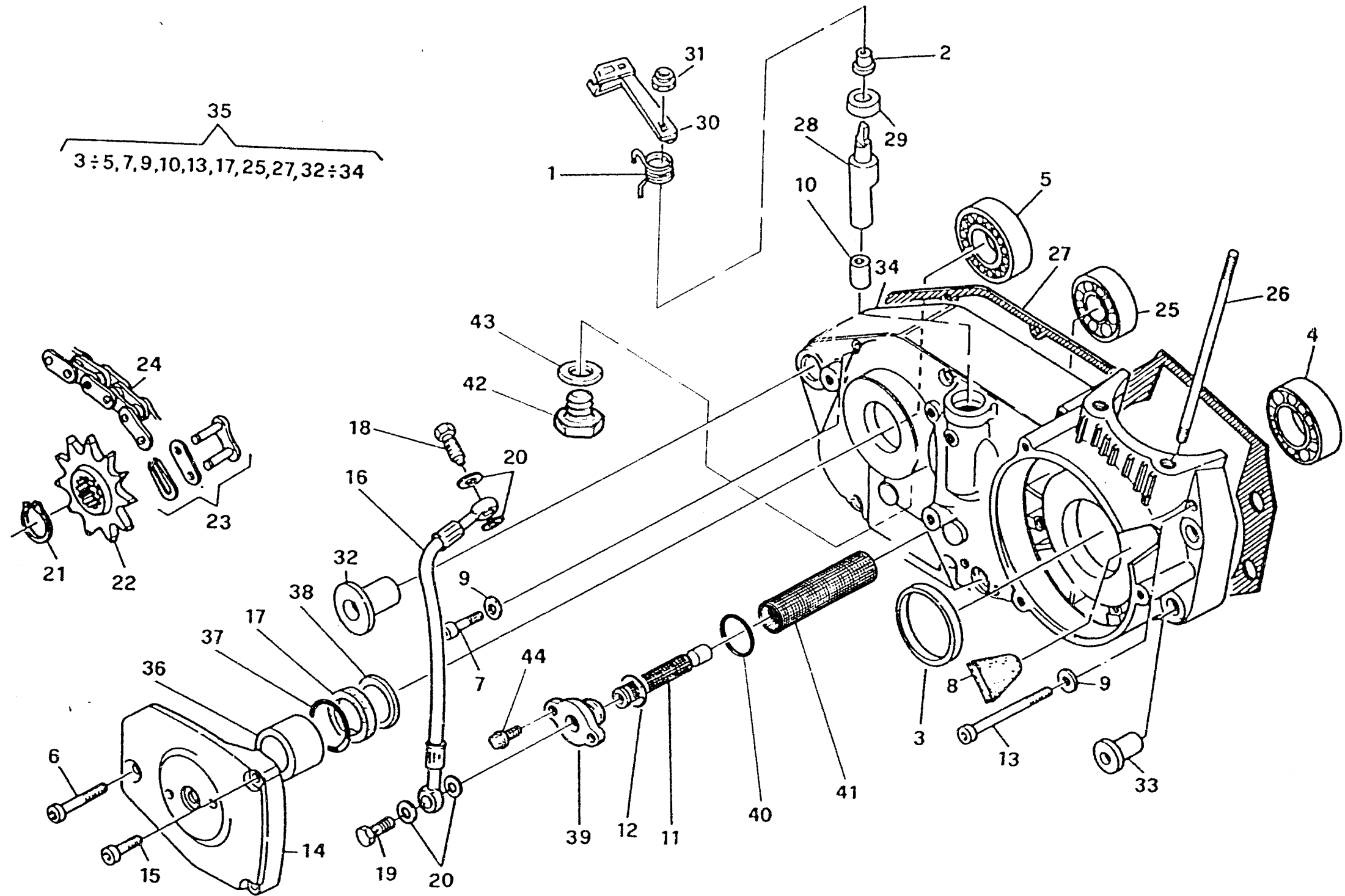



TE - TE U.S.A.
410 - 610 / 99
TC 610 / 99

TAVOLA
DRAWING
TABLE
BILD
TABLA

6

SEMICARTER DESTRO - R.H. HALF CRANKCASE
CARTER D. - GEHAUSEDECKEL R.
BANCADA DER.

Note Notes Marka Notas	Pos. No. Index Pos.	N. Cod. Code No. Nr. Code Code Nr N. Cod.	Q.tà Q.ty Q.te M.ge C.ad	DENOMINAZIONE	NAME	DESIGNATION	BESHREIBUNG	DENOMINACION	Validità Validité Gültig Validez
WUA	24	8A00 65442	1	Catena con OR Regina	Chain with OR	Chaîne avec OR	Kette mit OR	Cadena con OR	
WUA	24	8C00 79783	1	Catena con OR DID	Chain with OR	Chaîne avec OR	Kette mit OR	Cadena con OR	
CA	24	8B00 56768	1	Catena Regina	Chain	Chaîne	Kette	Cadena	
CA	24	8D00 79785	1	Catena DID	Chain	Chaîne	Kette	Cadena	
	25	8000 19768	1	Cuscinetto	Bearing	Roulement	Lager	Cojinete	
	26	1615 11601	4	Prigioniero cilindro (610)	Stud bolt (610)	Prisonnier (610)	Stiftschraube (610)	Prisionero (610)	
	26	8000 63819	4	Prigioniero cilindro (410)	Stud bolt (410)	Prisonnier (410)	Stiftschraube (410)	Prisionero (410)	
	27	1615 01403	1	Guarnizione	Gasket	Garnitue	Dichtung	Junta	
	28	8A00 68201	1	Albero comando frizione	Shaft	Arbre	Welle	Eje	
	29	1513 72201	1	Anello di tenuta	Seal ring	Bague d'étanchéité	Dichtungsring	Anillo de retención	
	30	8A00 68196	1	Leva	Lever	Levier	Hebel	Palanca	
	31	8000 56410	1	Dado	Nut	Ecrou	Mutter	Tuerca	
	32	1614 58901	1	Bussola	Bushing	Douille	Buchse	Manguito	
	33	1610 77701	2	Bussola	Bushing	Douille	Buchse	Manguito	
	35	8000 89899	1	Carter motore accoppiati compl.	Crankcase assy	Carter compl.	Kurberlgehäuse kpl.	Carter motor completo	
	36	8000 60464	1	Distanziale	Spacer	Entretoise	Distanzstück	Separador	
	37	8000 23110	1	Anello OR	O-Ring	Bague OR	O-Ring	Anillo OR	
	38	8A00 36022	1	Rosetta di rasamento Sp. 0,2	Washer	Rondelle	Scheibe	Arandela	
	33	8B00 36022	1	Rosetta di rasamento Sp. 0,3	Washer	Rondelle	Scheibe	Arandela	
	38	8C00 36022	1	Rosetta di rasamento Sp. 0,4	Washer	Rondelle	Scheibe	Arandela	
	38	8D00 36022	1	Rosetta di rasamento Sp. 0,5	Washer	Rondelle	Scheibe	Arandela	
	39	8A00 72425	1	Raccordo	Union	Raccord	Anschluss	Empaime	
	40	8000 34609	1	Anello di tenuta	Seal ring	Bague d'étanchéité	Dichtungsring	Anillo de retención	
	41	8000 72426	1	Filtro olio esterno	External oil filter	Filtre à huile	Ölfilter	Filtro aceite	
	42	0660 49053	1	Tappo	Plug	Bouchon	Verschluss	Tapón	
	43	62N0 15682	1	Rosetta	Washer	Rondelle	Scheibe	Arandela	
	44	8A00 66525	2	Vite	Screw	Vis	Schraube	Tomillo	

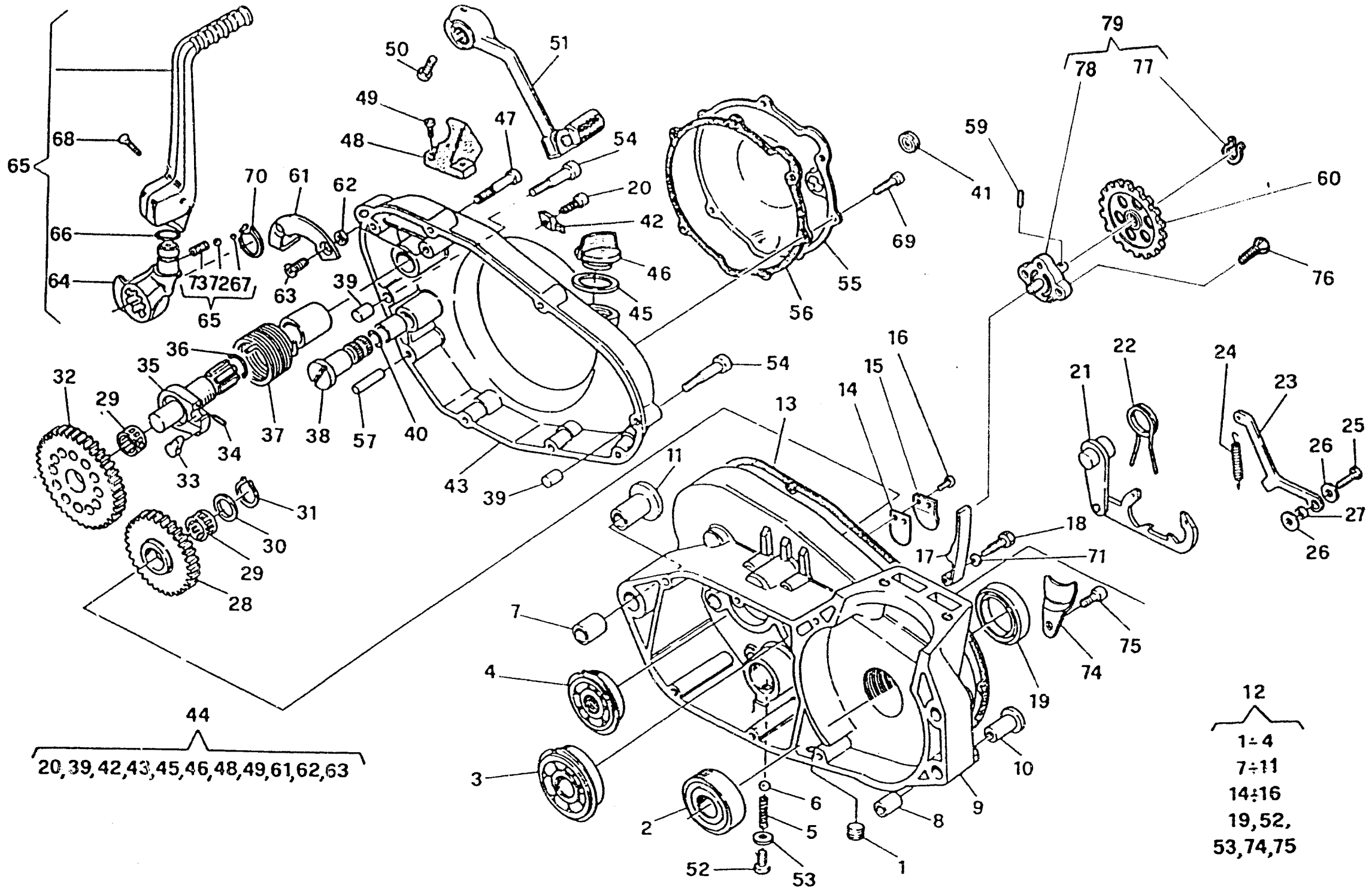

44
20, 39, 42, 43, 45, 46, 48, 49, 61, 62, 63

12
1-4
7-11
14-16
19, 52,
53, 74, 75



TE - TE U.S.A.
410 - 610 / 99
TC 610 / 99

TAVOLA
DRAWING
TABLE
BILD
TABLA

7

SEMICARTER SIN., AVVIAMENTO - L.H. HALF CRANKCASE, STARTING
CARTER G., DEMARRAGE - GEHAUSEDECKEL L., ANLASSER
BANCADA IZQ., ARRANQUE

Note Notes Notas	Pos. Nu. N. Index Pos.	N. Cod. Code No. Nr. Code Code Nr N. Cod.	Q.tà Q.ty Q.té M.ge C.ad	DENOMINAZIONE	NAME	DESIGNATION	BESCHREIBUNG	DENOMINACION	Validità Validity Validité Gültig Validez
	1	8000 69769	1	Tappo	Plug	Bouchon	Verschluss	Tapón	
	2	8A00 28182	1	Cuscinetto	Bearing	Roulement	Lager	Cojinete	
	3	8000 59975	1	Cuscinetto	Bearing	Roulement	Lager	Cojinete	
	4	8000 59976	1	Cuscinetto	Bearing	Roulement	Lager	Cojinete	
	5	8000 61263	1	Molla	Spring	Ressort	Feder	Resorte	
	6	8000 60476	1	Sfera	Ball	Bille	Kugel	Esfera	
	7	1614 59001	1	Bussola di riferimento	Bushing	Douille	Buchse	Manguito	
	8	1610 77601	1	Bussola di riferimento	Bushing	Douille	Buchse	Manguito	
	10	1610 77701	1	Bussola	Bushing	Douille	Buchse	Manguito	
	11	1614 58901	1	Bussola	Bushing	Douille	Buchse	Manguito	
	12	8000 89899	1	Carter motore accoppiati compl.	Crankcase assy	Carter compl.	Kurbergehäuse kpl.	Carter motor completi	
	13	1611 65003	1	Guarnizione	Gasket	Garnitue	Dichtung	Junta	
	14	1615 34801	1	Valvola lamellare	Reed valve	Soupape lamellaire	Ventil lamellar	Válvula laminar	
	15	1615 10501	1	Supporto	Support	Support	Halterung	Soporte elástico	
	16	60N1 02866	2	Vite	Screw	Vis	Schraube	Tornillo	
	17	8000 68686	1	Tendicatena distr.	Chain adjuster	Tendeur de chaine	Kettenspanner	Tensor de cadena	
	18	1615 35902	1	Vite	Screw	Vis	Schraube	Tornillo	
	19	1513 72602	1	Anello di tenuta	Seal ring	Bague d'étanchéité	Dichtungsring	Anillo de retención	
	20	8000 26970	1	Vite	Screw	Vis	Schraube	Tornillo	
	21	1611 68601	1	Selettore cambio	Selector	Selecteur	Wahler	Selector com.	
	22	1611 69201	1	Molla	Spring	Ressort	Feder	Resorte	
	23	8000 90054	1	Saltarello	Click	Cliquet	Strumhaken	Saltarelo	
	24	1611 68401	1	Molla	Spring	Ressort	Feder	Resorte	
	25	8000 47422	1	Vite	Screw	Vis	Schraube	Tornillo	
	26	8A00 37003	1	Rosetta piana	Washer	Rondelle	Scheibe	Arandela	
	27	1611 21601	1	Bussola	Bushing	Douille	Buchse	Manguito	
	28	1611 27101	1	Ingranaggio di rinvio	Gear	Engranage	Zahnrad	Engranaje	
	29	8000 40449	2	Cuscinetto a rullini	Needle bearing	Roulement à aiguilles	Nadelkäfig	Cojinete de rodillos	
	30	8000 38110	1	Rosetta di rasamento Sp.0,3	Washer	Rondelle	Scheibe	Arandela	
	30	8B00 38110	1	Rosetta di rasamento Sp.0,5	Washer	Rondelle	Scheibe	Arandela	
	30	8F00 38110	1	Rosetta di rasamento Sp.1,0	Washer	Rondelle	Scheibe	Arandela	
	31	66N0 21205	1	Anello di fermo	Stop ring	Bague d'arrêt	Haltering	Anillo de retención	

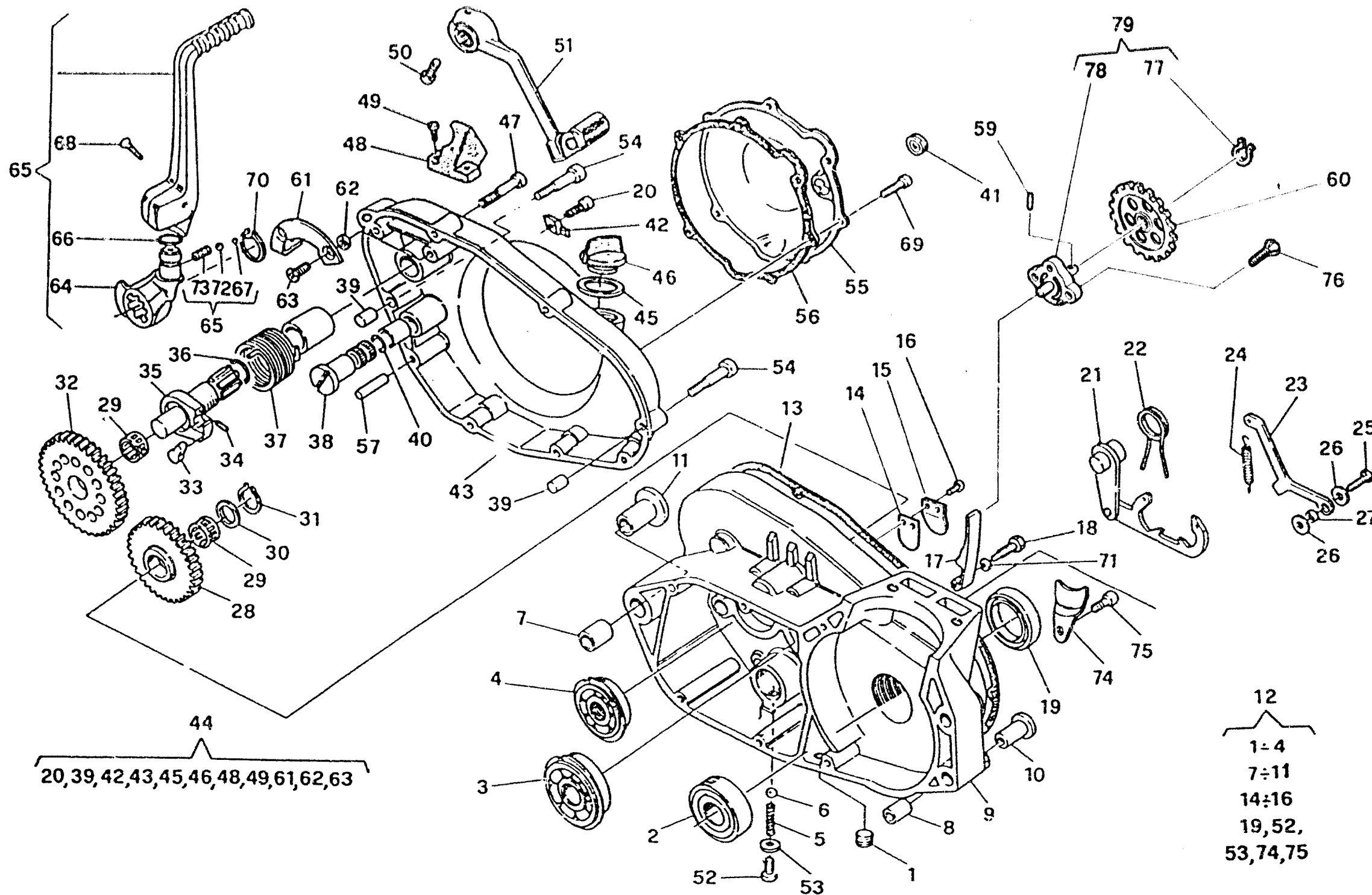

20, 39, 42, 43, 45, 46, 48, 49, 61, 62, 63

12
1-4
7-11
14-16
19, 52,
53, 74, 75



TE - TE U.S.A.
410 - 610 / 99
TC 610 / 99

TAVOLA
DRAWING
TABLE
BILD
TABLA

7

SEMICARTER SIN., AVVIAMENTO - L.H. HALF CRANKCASE, STARTING
CARTER G., DEMARRAGE - GEHAUSEDECKEL L., ANLASSER
BANCADA IZQ., ARRANQUE

Note Notes Notas	Pos. No. Index	N. Cod. Code No. Nr. Code Code Nr N. Cod.	Q.ia Q.ty Q.ite M. ge C. ad	DENOMINAZIONE	NAME	DESIGNATION	BESCHREIBUNG	DENOMINACION	Valida Valido Gültig Váldez
	32	1615 39101	1	Ingranaggio avviamento	Driven gear	Engrange conduit	Zahnrad	Engranaje conducto	
	33	1611 68001	1	Saltarello	Click	Cliquet	Strumhaken	Saltarelo	
	34	1611 68101	1	Molla	Spring	Ressort	Feder	Resorte	
	35	1611 67702	1	Albero avviamento	Starter crank shaft	Arbre de démarrage	Kickstarterwelle	Eje arranque	
	36	8000 60475	2	Anello OR	O-Ring	Bague OR	O-Ring	Anillo OR	
	37	1616 36201	1	Molla	Spring	Ressort	Feder	Resorte	
	38	1611 74601	1	Albero pedale cambio	Gearbox pedal shaft	Arbre pédale change de vitesse	Pedal Umsteuerungswelle	Eje pedal cambio	
	39	1611 70801	2	Spina di riferimento	Pin	Goupille	Stift	Clavija	
	40	8000 60474	2	Anello OR	O-Ring	Bague OR	O-Ring	Anillo OR	
	41	8000 53340	1	Oblò	Inspection plug	Capuchon de inspection	Stopfen	Portilla	
	42	8000 68710	1	Gommino	Rubber pad	Pièce caoutchouc	Gummistück	Junta de goma	
	44	8A00 75764	1	Coperchio trasmissione compl.	Cover	Couvercle	Deckel	Tapa	
	45	8000 27960	1	Guarnizione	Gasket	Garnitue	Dichtung	Junta	
	46	8000 36786	1	Tappo	Plug	Bouchon	Verschluss	Tapón	
	47	60N1 02512	5	Vite	Screw	Vis	Schraube	Tomillo	
	48	8000 68584	1	Tampone ferma pedale	Pad	Tampon	Stopfen	Tampón	
	49	60N1 02900	2	Vite	Screw	Vis	Schraube	Tomillo	
	50	60N1 02510	1	Vite	Screw	Vis	Schraube	Tomillo	
	51	8000 69983	1	Leva cambio compl.	Gearchange lever	Levier comm. vitesse	Schalthebel	Palanca del cambio	
	52	8000 66101	1	Vite	Screw	Vis	Schraube	Tomillo	
	53	8000 47763	1	Bussola	Bushing	Douille	Buchse	Manguito	
	54	60N1 02513	2	Vite	Screw	Vis	Schraube	Tomillo	
	55	8A00 67216	1	Coperchio	Cover	Couvercle	Deckel	Tapa	
	56	8000 68191	1	Guarnizione	Gasket	Garnitue	Dichtung	Junta	
	57	8000 60477	1	Spina di riferimento	Pin	Goupille	Stift	Clavija	
	59	8C00 27690	1	Rullino	Roller	Aiguille	Rolle	Rodillo	
	60	8000 90052	1	Ingranaggio pompa	Pump gear	Engrenage	Zahnrad	Engranaje	
	61	1611 70401	1	Piastrina fine corsa	Plate	Plaquette	Plättchen	Placa	
	62	1611 70601	2	Distanziale	Spacer	Entretoise	Distanzstück	Separador	
	63	8000 60577	2	Vite	Screw	Vis	Schraube	Tomillo	
	64	8000 68174	1	Mozzetto	Hub	Moyeau	Radnabe	Cubo	
	65	8000 84321	1	Pedale avviamento completo	Pedal	Pedale	Pedal	Pedal	

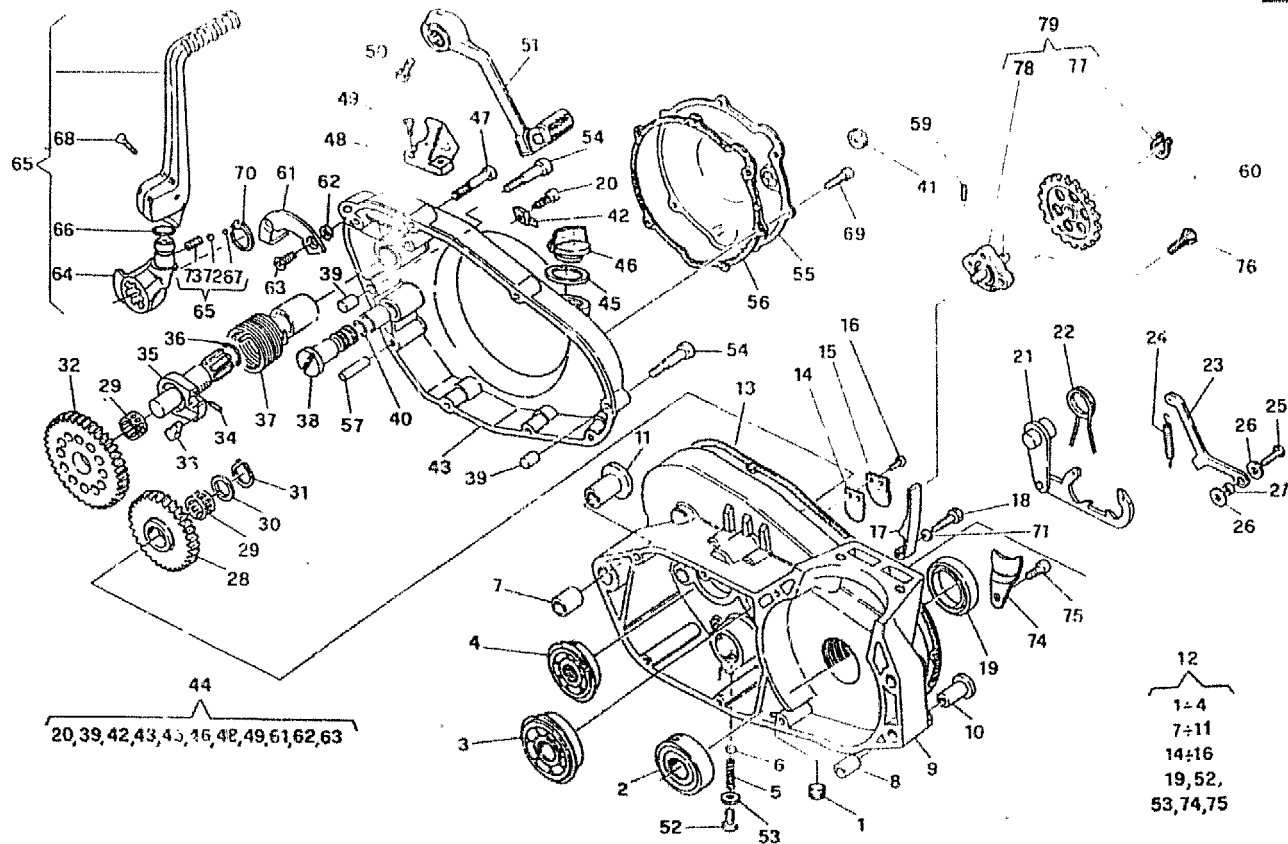



TE - TE U.S.A.
410 - 610 / 99
TC 610 / 99

TAVOLA
DRAWING
TABLE
BILD
TABLA

7

SEMICARTER SIN., AVVIAMENTO - L.H. HALF CRANKCASE, STARTING
CARTER G., DEMARRAGE - GEHAUSEDECKEL L., ANLASSER
BANCADA IZQ., ARRANQUE

Note Notes Marka Notas	Pos. No. N. Index Pos.	N. Cod. Code No. Nr. Code Code Nr N. Cod.	Q. IA Q. ty Q. te M. ge C. ad	DENOMINAZIONE	NAME	DESIGNATION	BESCHREIBUNG	DENOMINACION	Valida Validity Vahdie Gültig Valdez
	66	8000 31271	1	Anello OR	O-Ring	Bague OR	O-Ring	Anillo OR	
	67	1611 08501	1	Tappo	Plug	Bouchon	Verschluss	Tapón	
	68	8000 58140	1	Vite	Screw	Vis	Schraube	Tornillo	
	69	60N1 07335	6	Vite	Screw	Vis	Schraube	Tornillo	
	70	66N0 21208	1	Anello di fermo	Stop ring	Bague d'arrêt	Haltering	Anillo de retención	
	71	8000 45194	1	Rosetta	Washer	Rondelle	Scheibe	Arandela	
	72	8000 60472	1	Sfera	Ball	Bille	Kugel	Esfera	
	73	1611 08401	1	Molla	Spring	Ressort	Feder	Resorte	
	74	8000 61269	1	Piastrina	Plate	Plaquette	Plättchen	Placa	
	75	60N1 02504	1	Vite	Screw	Vis	Schraube	Tornillo	
	76	8000 60577	2	Vite	Screw	Vis	Schraube	Tornillo	
	77	8000 90057	1	Anello elastico	Split ring	Anneau ressort	Sprengring	Anillo elástico	
	78	8000 89829	1	Pompa olio	Oil pump	Pompe huile	ölpumpen	Bombeadora aceite	
	79	8000 90056	1	Ass. pompa olio	Oil pump assy	Groupe pompe huile	ölpumpen Kpl	Grupo bombeadora aceite	

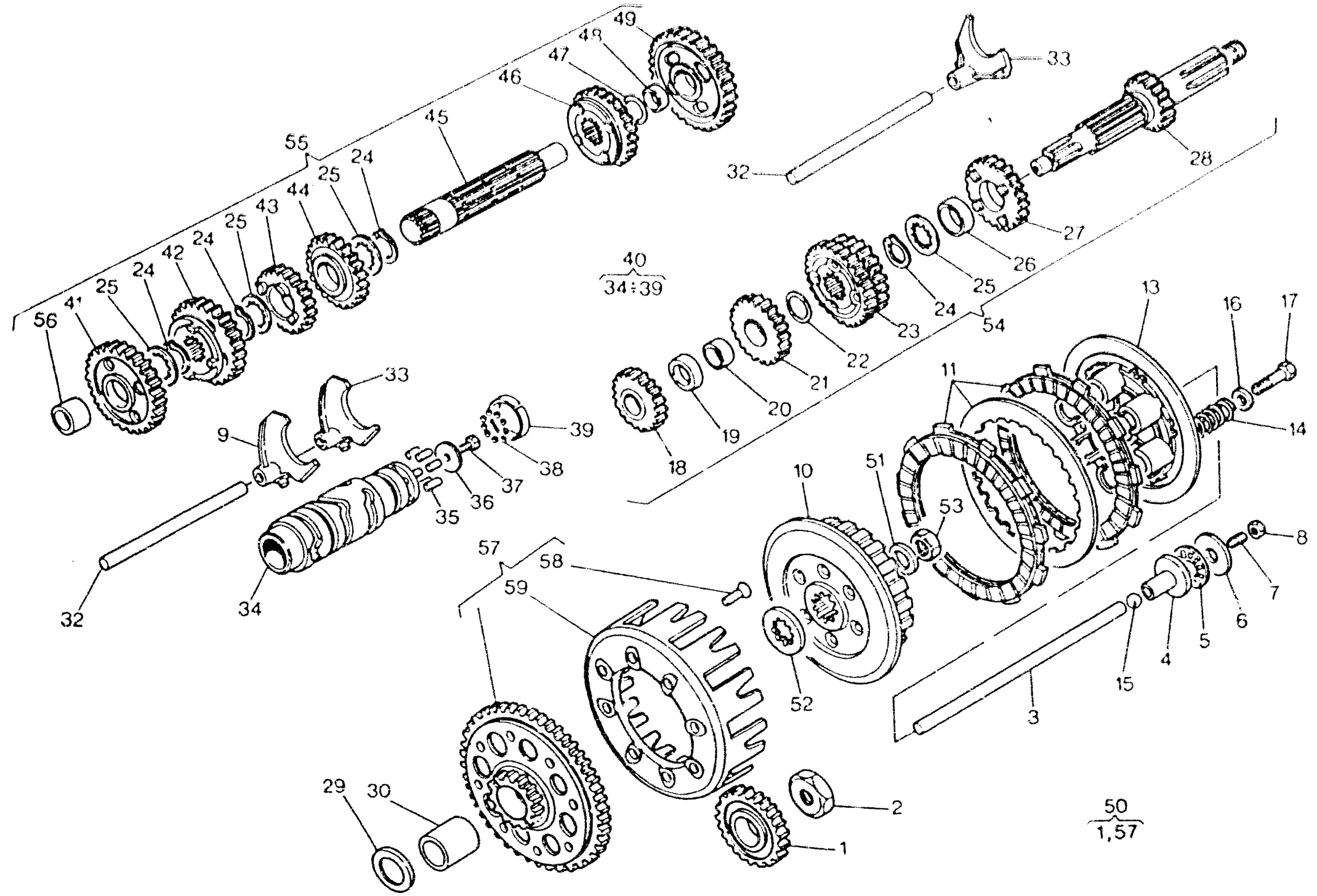



TE - TE U.S.A.
410 - 610 / 99

TAVOLA
DRAWING
TABLE
BILD
TABLA

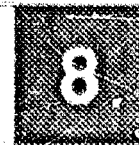

CAMBIO, COMANDO CAMBIO, FRIZIONE - TRANSMISSION, SHIFTER, CLUTCH
BOÎTE DE VITESSE, COMMANDE DE VITESSE, EMBRAYAGE
WECHSELGETRIEBE, GANGSCHALTUNG, KUPPLUNG - CAMBIO, MANDO CAMBIO, ENBRAGUE

Note Notes Marka Notas	Pos. No. Index Pos.	N. Cod. Code No. Nr. Code Code Nr. N. Cod.	Q1A Q1y Q1e M ge C ad	DENOMINAZIONE	NAME	DESIGNATION	BESCHREIBUNG	DENOMINACION	Vertrieb Vertrieb Vertrieb Vertrieb
	1	8000 69715	1	Ingranaggio conduttore	Driving gear	Engraiage conducteur	Zahnrad	Engranaje conductor	
	2	8000 59965	1	Dado	Nut	Ecrou	Mutter	Tuerca	
	3	1615 31502	1	Asta di forza	Fork tube	Barre de force	Druckstab	Varilla de fuerza	
	4	8000 54477	1	Piattello	Plate	Plateau	Teller	Placa	
	5	8000 35780	1	Cuscinetto assiale	Bearing	Roulement	Kugellager	Cojinete	
	6	8000 35781	1	Rosetta	Washer	Rondelle	Scheibe	Arandela	
	7	8000 54692	1	Vite	Screw	Vis	Schraube	Tornillo	
	8	61N1 15062	1	Dado	Nut	Ecrou	Mutter	Tuerca	
	9	8000 63425	1	Forcella 3 ^a vel.	Fork	Fourche	Gabel	Horquilla	
	10	8A00 48137	1	Mozzo frizione	Hub	Moyeau	Radnabe	Cubo	
	11	8B00 82861	1	Ass. gruppo frizione	Clutch group assy	Groupe embrayage compl.	Kupplungsgruppe Kpl	Grupo embrague compl.	
	13	8000 48138	1	Piastra spingidisci	Plate	Plaque	Platte	Placa	
	14	8000 71230	5	Molla frizione	Clutch spring	Ressort embrayage	Kupplungsfeder	Resorte embrague	
	15	6BN0 21509	1	Sfera	Ball	Bille	Kugel	Esfera	
	16	8000 21535	5	Rosetta	Washer	Rondelle	Scheibe	Arandela	
	17	60N1 01081	5	Vite	Screw	Vis	Schraube	Tornillo	
	18	1612 36201	1	Ingranaggio 2 ^a A.P.	Main shaft 2nd gear	Engrenage 2ème vitesse A.P.	Zahn. 1. 2. Geschw. Antriebsw.	Engranaje 2 ^o velocidad Eje P.	
	19	1612 48101	1	Distanziale	Spacer	Entretoise	Distanzstück	Separador	
	20	1612 48001	1	Bussola	Bushing	Douille	Buchse	Manguito	
	21	1612 36301	1	Ingranaggio 3 ^a A.P.	Main shaft 3rd gear	Engrenage 3ème vitesse A.P.	Zahn. 1. 3. Geschw. Antriebsw.	Engranaje 3 ^o velocidad Eje P.	
	22	1612 84201	1	Rosetta	Washer	Rondelle	Scheibe	Arandela	
	23	1612 39001	1	Ingran. 5 ^a e 6 ^a A.P.	Gear 5th - 6th speed	Engrenage 5ème 6ème	Zahnrad 5. - 6. Gang	Engranaje 5 ^o - 6 ^o velocidad	
	24	66N0 21211	4	Anello di fermo	Stop ring	Bague d'arrêt	Haltering	Anillo de retención	
	25	1611 71701	4	Rosetta	Washer	Rondelle	Scheibe	Arandela	
	26	8000 63821	1	Bussola	Bushing	Douille	Buchse	Manguito	
	27	1611 83701	1	Ingranaggio 4 ^a A.P.	Main shaft 4th gear	Engrenage 4ème vitesse A.P.	Zahn. 1. 4. Geschw. Antriebsw.	Engranaje 4 ^o velocidad Eje P.	
	28	8000 69736	1	Albero primario	Main shaft	Arbre primaire	Hauptwelle	Eje primario	
	29	8E00 30053	1	Rosetta di rasamento	Washer	Rondelle	Scheibe	Arandela	
	30	1615 38901	1	Bussola	Bushing	Douille	Buchse	Manguito	
	32	1611 69901	2	Perno	Pin	Pivot	Bolzen	Perno	
	33	1612 38401	2	Forcella cambio	Fork	Fourche	Gabel	Horquilla	
	35	8000 35823	6	Rullino	Roller	Aiguille	Rolle	Rodillo	

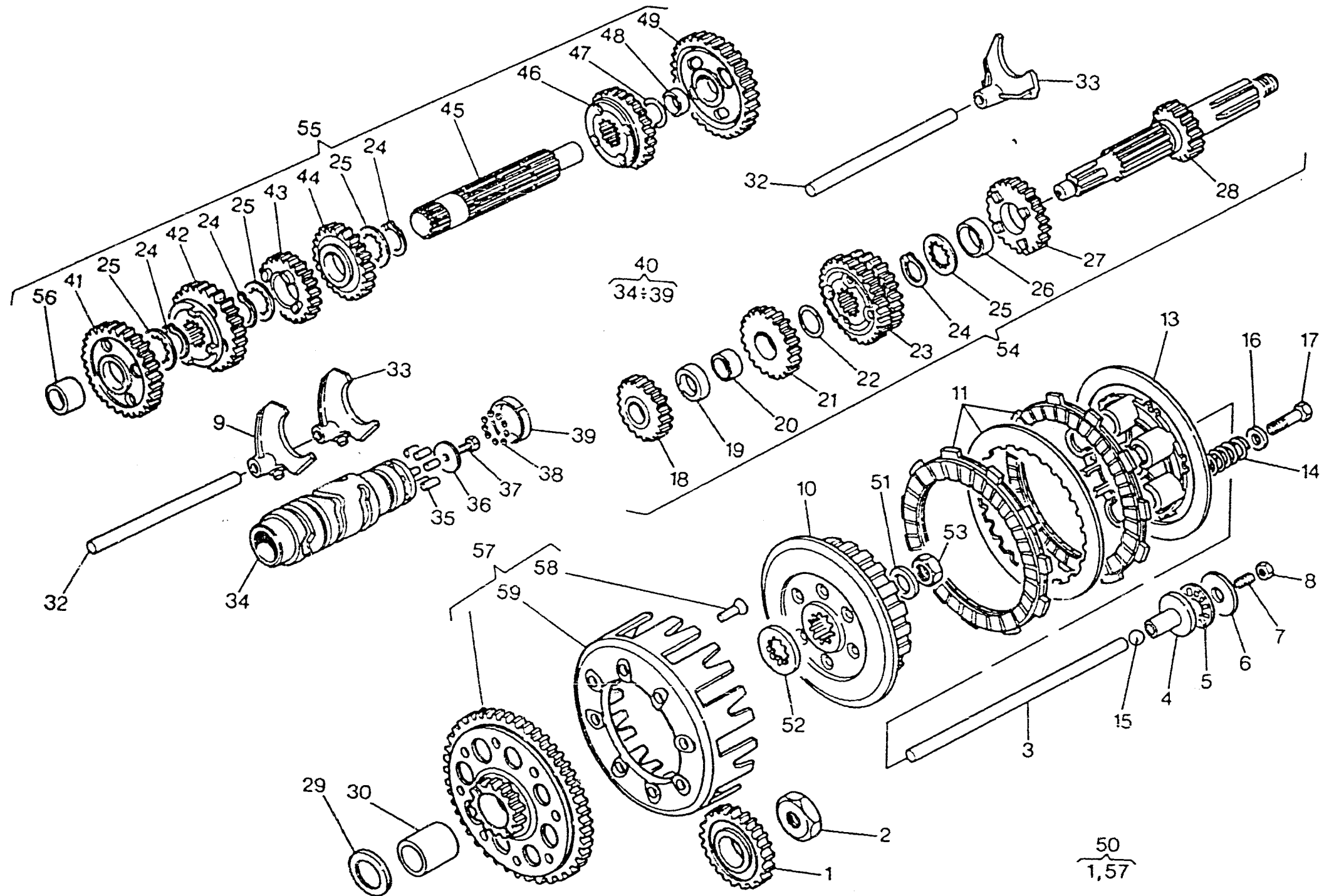



TE - TE U.S.A.
410 - 610 / 99

TAVOLA
DRAWING
TABLE
BILD
TABLA

8

CAMBIO, COMANDO CAMBIO, FRIZIONE - TRANSMISSION, SHIFTER, CLUTCH
BOITE DE VITESSE, COMMANDE DE VITESSE, EMBRAYAGE
WECHSELGETRIEBE, GANGSCHALTUNG, KUPPLUNG - CAMBIO, MANDO CAMBIO, ENBRAGUE

Note Notes Notas	Pos. No. Index Pos.	N. Cod. Code No. Nr. Code Code Nr N. Cod.	Q.tà Q.ty Q.te M.ge C.ad	DENOMINAZIONE	NAME	DESIGNATION	BESHREIBUNG	DENCMINACION	Validità Validity Validé Gültig Validez
	36	8000 30326	1	Rosetta	Washer	Rondelle	Scheibe	Arandela	
	37	8000 60473	1	Vite	Screw	Vis	Schraube	Tomillo	
	38	8000 60472	11	Sfera	Ball	Bille	Kugel	Esfera	
	39	1612 69901	1	Anello esterno	Ring	Bague	Ring	Anillo	
	40	1611 70101	1	Albero forcelle cambio compl.	Driving shaft gearbox forks	Arbre comm. fourches trans.	Antriebswelle Schaltgabel	Eje mando horquilla cambio	
	41	1612 36502	1	Ingranaggio 2 ^a A.S.	Secondary shaft 2nd gear	Engrenage 2ème vitesse A.S.	Zah. f. 2. Geschw. Vorgelegew.	Engranaje 2° velocidad Eje S.	
	42	8000 63424	1	Ingranaggio 3 ^a A.S.	Secondary shaft 3rd gear	Engrenage 3ème vitesse A.S.	Zah. f. 3. Geschw. Vorgelegew.	Engranaje 3° velocidad Eje S.	
	43	1612 35701	1	Ingranaggio 6 ^a A.S.	Secondary shaft 6th gear	Engrenage 6ème vitesse A.S.	Zah. f. 6. Geschw. Vorgelegew.	Engranaje 6° velocidad Eje S.	
	44	1611 71501	1	Ingranaggio 5 ^a A.S.	Secondary shaft 5th gear	Engrenage 5ème vitesse A.S.	Zah. f. 5. Geschw. Vorgelegew.	Engranaje 5° velocidad Eje S.	
	45	8000 60463	1	Albero secondario	Layshaft	Arbre secondaire	Vorgelegewelle	Eje secundario	
	46	1612 38801	1	Ingranaggio 4 ^a A.S.	Secondary shaft 4th gear	Engrenage 4ème vitesse A.S.	Zah. f. 4. Geschw. Vorgelegew.	Engranaje 4° velocidad Eje S.	
	47	1513 71401	1	Rosetta	Washer	Rondelle	Scheibe	Arandela	
	48	1612 41501	1	Bussola	Bushing	Douille	Buchse	Manguito	
	49	1612 36101	1	Ingranaggio 1 ^a A.S.	Gear 1st speed	Engrenage 1ère	Zahnrad 1. Gang	Engranaje 1° velocidad	
	50	8000 69729	1	Coppia ingran. trasm. primaria	Set of matched primary	Engrenages trans. prim.	Stirnradpaar	Copla engranaje trans. primaria	
	51	8000 36857	1	Rosetta di sicurezza	Washer	Rondelle	Scheibe	Arandela	
	52	8A00 38350	1	Rosetta	Washer	Rondelle	Scheibe	Arandela	
	53	8000 36856	1	Dado	Nut	Ecrou	Mutter	Tuerca	
	54	8000 69737	1	Albero primario completo	Main shaft	Arbre primaire	Hauptwelle	Eje principal completo	
	55	8000 60470	1	Albero secondario completo	Layshaft compl.	Arbre secondaire compl.	Vorgelegewelle kpl.	Eje secundario completo compl.	
	56	8000 63822	1	Bussola	Bushing	Douille	Buchse	Manguito	
	57	8000 69722	1	Campana frizione completo	Clutch housing compl.	Cage embrayage compl.	Kupplungskorb kpl.	Campana embrague compl.	
	58	63N0 16374	8	Ribattino	Rivet	Rivet	Niet	Remache	
	59	8000 69723	1	Campana frizione	Clutch housing	Cage embrayage	Kupplungskorb	Campana embrague	

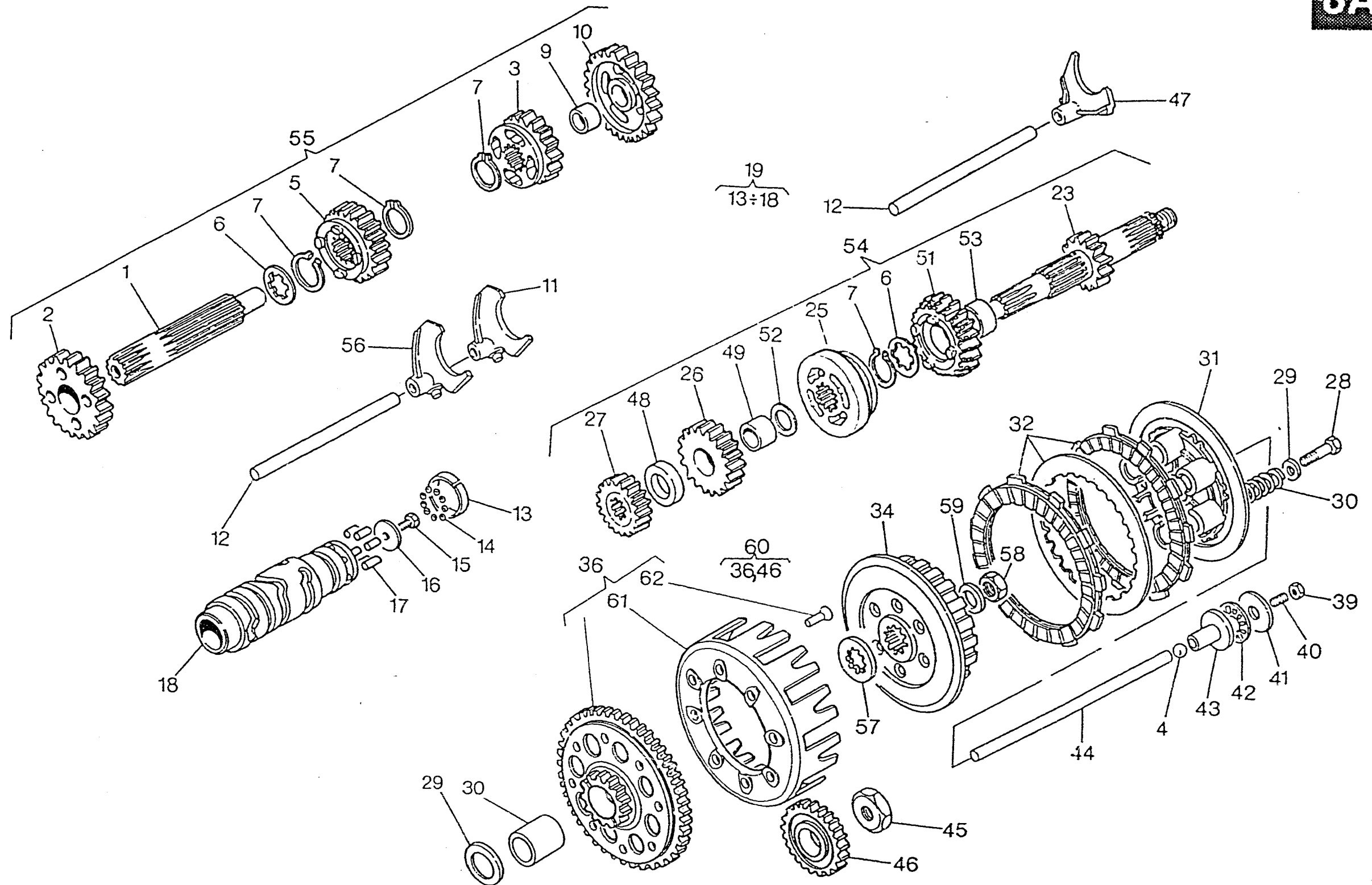



TC 610 / 99

TAVOLA
DRAWING
TABLE
BILD
TABELA

8A

CAMBIO, COMANDO CAMBIO, FRIZIONE - TRANSMISSION, SHIFTER, CLUTCH
BOITE DE VITESSE, COMMANDE DE VITESSE, EMBRAYAGE
WECHSELGETRIEBE, GANGSCHALTUNG, KUPPLUNG - CAMBIO, MANDO CAMBIO, ENBRAGUE

Note Notes Notas	Pos. No. Index Pos.	N. Cod. Code No. Nr. Code Code Nr N. Cod.	Q.tà Q.ty Q.te M.ge C.ad	DENOMINAZIONE	NAME	DESIGNATION	BESHREIBUNG	DENOMINACION	Validità Validity Validez Gültig Validez
	1	8000 60526	1	Albero secondario	Layshaft	Arbre secondaire	Vorgelegewelle	Eje secundario	
	2	1616 02201	1	Ingranaggio 2 ^a A.S.	Secondary shaft 2nd gear	Engrenage 2ème vitesse A.S.	Zah. f. 2. Geschw. Vorgelegew.	Engranaje 2° velocidad Eje S.	
	3	8000 80861	1	Ingranaggio 4 ^a A.S.	Secondary shaft 4th gear	Engrenage 4ème vitesse A.S.	Zah. f. 4. Geschw. Vorgelegew.	Engranaje 4° velocidad Eje S.	
	4	6BN0 21509	1	Sfera	Ball	Bille	Kugel	Esfera	
	5	8000 80860	1	Ingranaggio 3 ^a A.S.	Secondary shaft 3rd gear	Engrenage 3ème vitesse A.S.	Zah. f. 3. Geschw. Vorgelegew.	Engranaje 3° velocidad Eje S.	
	6	1611 71701	2	Rosetta	Washer	Rondelle	Scheibe	Arandela	
	7	66N0 21211	4	Anello di fermo	Stop ring	Bague d'arrêt	Haltering	Anillo de retención	
	9	1612 41501	1	Bussola	Bushing	Douille	Buchse	Manguito	
	10	8000 82213	1	Ingranaggio 1 ^a A.S.	Gear 1st speed	Engrenage 1ère	Zahnrad 1. Gang	Engranaje 1° velocidad	
	11	1612 38401	1	Forcella cambio	Fork	Fourche	Gabel	Horquilla	
	12	1611 69901	2	Perno	Pin	Pivot	Bolzen	Perno	
	13	1612 69901	1	Anello esterno	Ring	Bague	Ring	Anillo	
	14	8000 60472	11	Sfera	Ball	Bille	Kugel	Esfera	
	15	8000 60473	1	Vite	Screw	Vis	Schraube	Tornillo	
	16	8000 30326	1	Rosetta	Washer	Rondelle	Scheibe	Arandela	
	17	8000 35823	6	Rullino	Roller	Aiguille	Rolle	Rodillo	
	19	8000 87566	1	Albero forcelle cambio compl.	Driving shaft gearbox forks	Arbre comm. fourches trans.	Antriebswelle Schaltgabel	Eje mando horquilla cambio	
	20	8E00 30053	1	Rosetta di rasamento	Washer	Rondelle	Scheibe	Arandela	
	22	1615 38801	1	Bussola	Bushing	Douille	Buchse	Manguito	
	23	8000 82212	1	Albero primario	Main shaft	Arbre primaire	Hauptwelle	Eje primario	
	25	8000 80854	1	Distanziale innesto 3 ^a A.P.	Spacer 3th speed	Entretoise 3ème	Distanzstück 3. Gang	Separador 3° velocidad	
	26	8000 80855	1	Ingranaggio 3 ^a A.P.	Main shaft 3rd gear	Engrenage 3ème vitesse A.P.	Zahn. f. 3. Geschw. Antriebsw.	Engranaje 3° velocidad Eje P.	
	27	1616 01701	1	Ingranaggio 2 ^a A.P.	Main shaft 2nd gear	Engrenage 2ème vitesse A.P.	Zahn. f. 2. Geschw. Antriebsw.	Engranaje 2° velocidad Eje P.	
	28	60N1 01081	5	Vite	Screw	Vis	Schraube	Tornillo	
	29	8000 21535	5	Rosetta	Washer	Rondelle	Scheibe	Arandela	
	30	8000 71230	5	Molla frizione	Clutch spring	Ressort embrayage	Kupplungsfeder	Resorte embrague	
	31	8000 48138	1	Piastra spingidisci	Plate	Plaque	Platte	Placa	
	32	8B00 82861	1	Ass. gruppo frizione	Clutch group assy	Groupe embrayage compl.	Kupplungsgruppe Kpl	Grupo embrague compl.	
	34	8A00 48137	1	Mozzo frizione	Hub	Moyeau	Radnabe	Cubo	
	36	8000 69722	1	Campana frizione completo	Clutch housing compl.	Cage embrayage compl.	Kupplungskorb kpl.	Campana embrague compl.	
	39	61N1 15062	1	Dado	Nut	Ecrou	Mutter	Tuerca	
	40	8000 54692	1	Vite	Screw	Vis	Schraube	Tornillo	

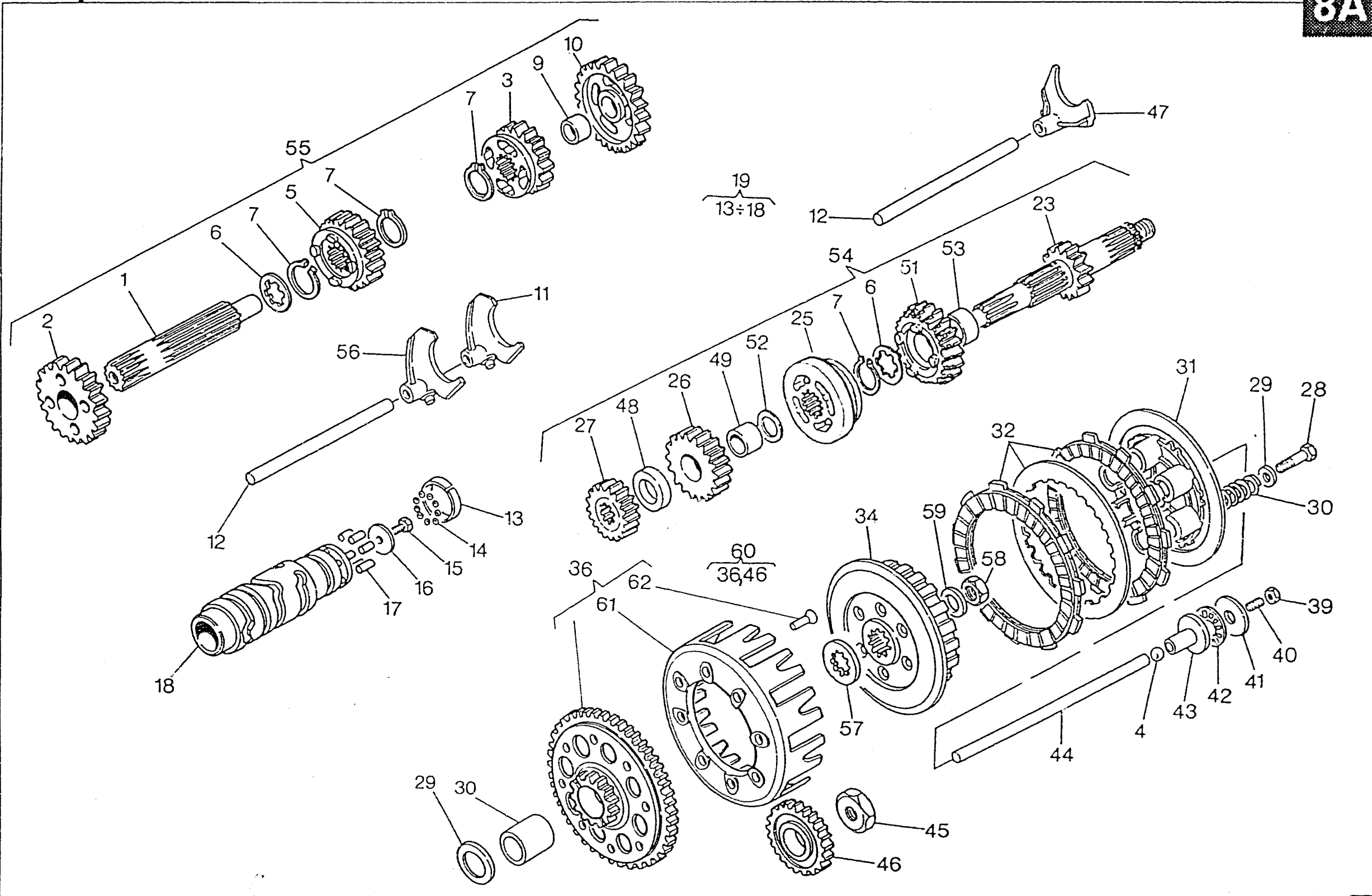



TC 610 / 99

TAVOLA
DRAWING
TABLE
BILD
TABLA

8A

CAMBIO, COMANDO CAMBIO, FRIZIONE - TRANSMISSION, SHIFTER, CLUTCH
BOITE DE VITESSE, COMMANDE DE VITESSE, EMBRAYAGE
WECHSELGETRIEBE, GANGSCHALTUNG, KUPPLUNG - CAMBIO, MANDO CAMBIO, ENBRAGUE

Note Notes Marka Notas	Pos. No. Index Pos.	N. Cod. Code No. Nr. Code Code Nr N. Cod.	Q.tà Q.ty Q.te M.ge C.ad	DENOMINAZIONE	NAME	DESIGNATION	BESHREIBUNG	DENOMINACION	Validità Validity Validité Gültig Validez
	41	8000 35781	1	Rosetta	Washer	Rondelle	Scheibe	Arandela	
	42	8000 35780	1	Cuscinetto assiale	Bearing	Roulement	Kugellager	Cojinete	
	43	8000 54477	1	Piattello	Plate	Plateau	Teller	Placa	
	44	1615 31502	1	Asta di forza	Fork tube	Barre de force	Druckstab	Varilla de fuerza	
	45	8000 59965	1	Dado	Nut	Ecrou	Mutter	Tuerca	
	46	8000 69715	1	Ingranaggio conduttore	Driving gear	Engranage conducteur	Zahnrad	Engranaje conductor	
	47	1616 01501	1	Forcella cambio	Fork	Fourche	Gabel	Horquilla	
	48	1616 02701	1	Distanziale	Spacer	Entretoise	Distanzstück	Separador	
	49	1616 36001	1	Bussola	Bushing	Douille	Buchse	Manguito	
	51	8000 80856	1	Ingranaggio 4 ^a A.P.	Main shaft 4th gear	Engrenage 4ème vitesse A.P.	Zahnw. f. 4. Geschw. Antriebsw.	Engranaje 4° velocidad Eje P.	
	52	1612 84201	1	Rosetta	Washer	Rondelle	Scheibe	Arandela	
	53	8000 63798	1	Bussola	Bushing	Douille	Buchse	Manguito	
	54	8000 87251	1	Albero primario completo	Main shaft	Arbre primaire	Hauptwelle	Eje principal completo	
	55	8000 87520	1	Albero secondario completo	Layshaft compl.	Arbre secondaire compl.	Vorgelegewelle kpl.	Eje secundario completo compl.	
	56	8000 63425	1	Forcella 3 ^a vel. sul secondario	Fork	Fourche	Gabel	Horquilla	
	57	8A00 38350	1	Rosetta	Washer	Rondelle	Scheibe	Arandela	
	58	8000 36856	1	Dado	Nut	Ecrou	Mutter	Tuerca	
	59	8000 36857	1	Rosetta di sicurezza	Washer	Rondelle	Scheibe	Arandela	
	60	8000 69729	1	Coppia ingran. trasm. primaria	Set of matched primary	Engrenages trans. prim.	Stirnradpaar	Copla engranaje trans. primaria	
	61	8000 69723	1	Campana frizione	Clutch housing	Cage embrayage	Kupplungskorb	Campana embrague	
	62	63N0 16374	8	Ribattino	Rivet	Rivet	Niet	Remache	

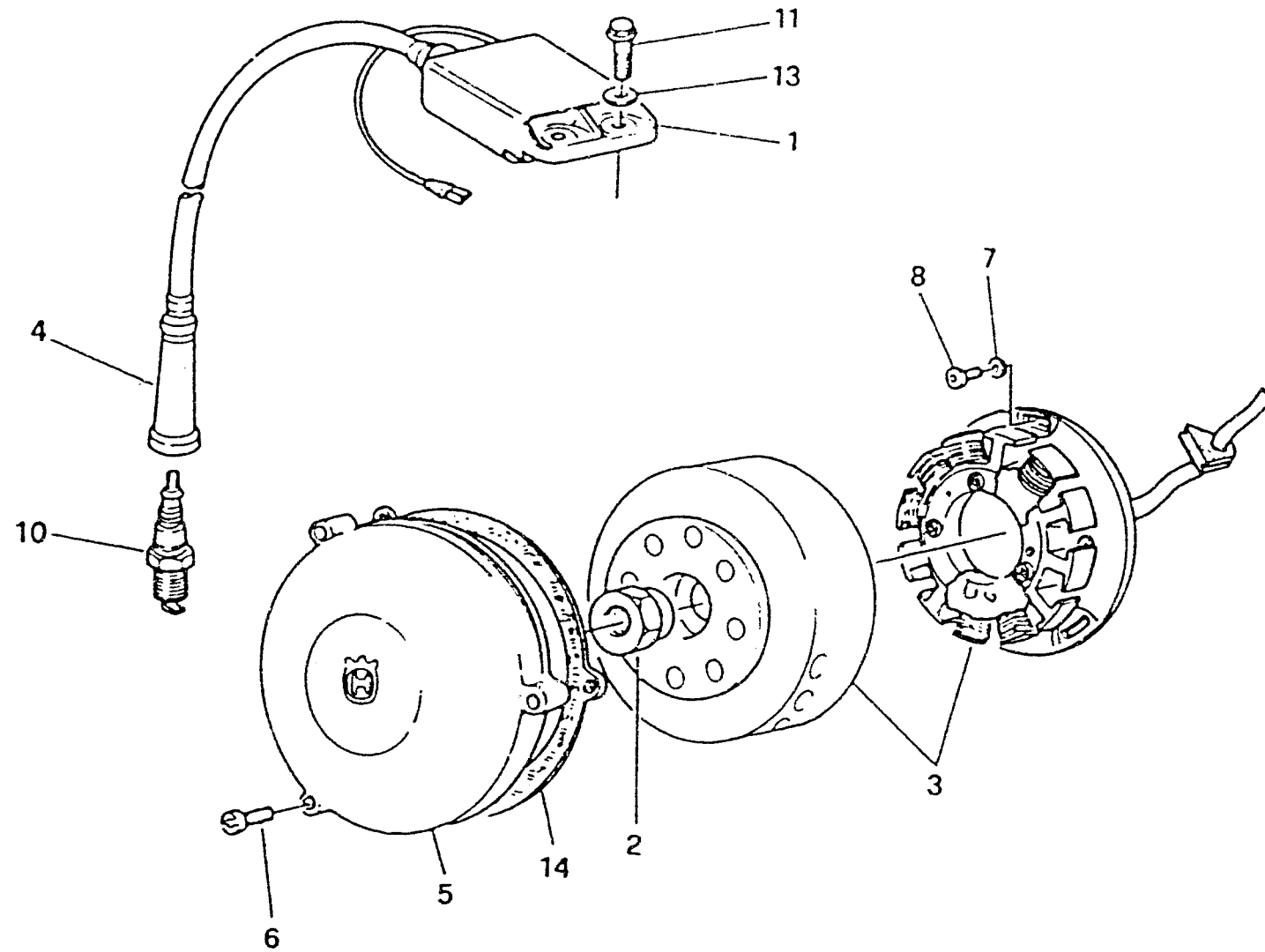



TE - TE U.S.A.
410 - 610 / 99
TC 610 / 99

TAVOLA
DRAWING
TABLE
BILD
TABLA

9

ACCENSIONE - IGNITION
ALLUMAGE - ZUNDUNG
ENCENDIDO

Note Notes Marka Notas	Pos. No. N. Index Pos.	N. Cod. Code No. Nr. Code Code Nr N. Cod.	Q.tà Q.ty Q.té M.ge C.ad	DE.NOMINAZIONE	NAME	DESIGNATION	BESHREIBUNG	DENOMINACION	Validità Validity Validité Gültig Validez
	1	8000 75451	1	Bobina completa	Coil compl.	Bobine compl.	Zündspule kpl.	Bobina compl.	
	2	8A00 59964	1	Dado	Nut	Ecrou	Mutter	Tuerca	
	3	8000 77391	1	Alternatore compl.	Alternator compl.	Alternateur compl.	Lichtmaschine kpl.	Alternador compl.	
WU	4	1615 38201	1	Cappuccio candela	Cap	Capuchon	Kappe	Capuchón	
C	4	8000 85419	1	Cappuccio candela	Cap	Capuchon	Kappe	Capuchón	
	5	80C0 60559	1	Coperchio accensione	Cover	Couvercle	Deckel	Tapa	
	6	60N1 02513	3	Vite	Screw	Vis	Schraube	Tornillo	
	7	8000 85322	3	Rosetta	Washer	Rondelle	Scheibe	Arandela	
	8	60N1 02487	3	Vite	Screw	Vis	Schraube	Tornillo	
A	10	1615 38301	1	Candela NGK	Spark plug	Bougie	Zündkerze	Bujía	
A	10	8000 77478	1	Candela CHAMPION	Spark plug	Bougie	Zündkerze	Bujía	
	11	8C00 67997	2	Vite	Screw	Vis	Schraube	Tornillo	
	13	62N4 15548	2	Rosetta	Washer	Rondelle	Scheibe	Arandela	
	14	1615 27501	1	Guarnizione	Gasket	Garnitue	Dichtung	Junta	

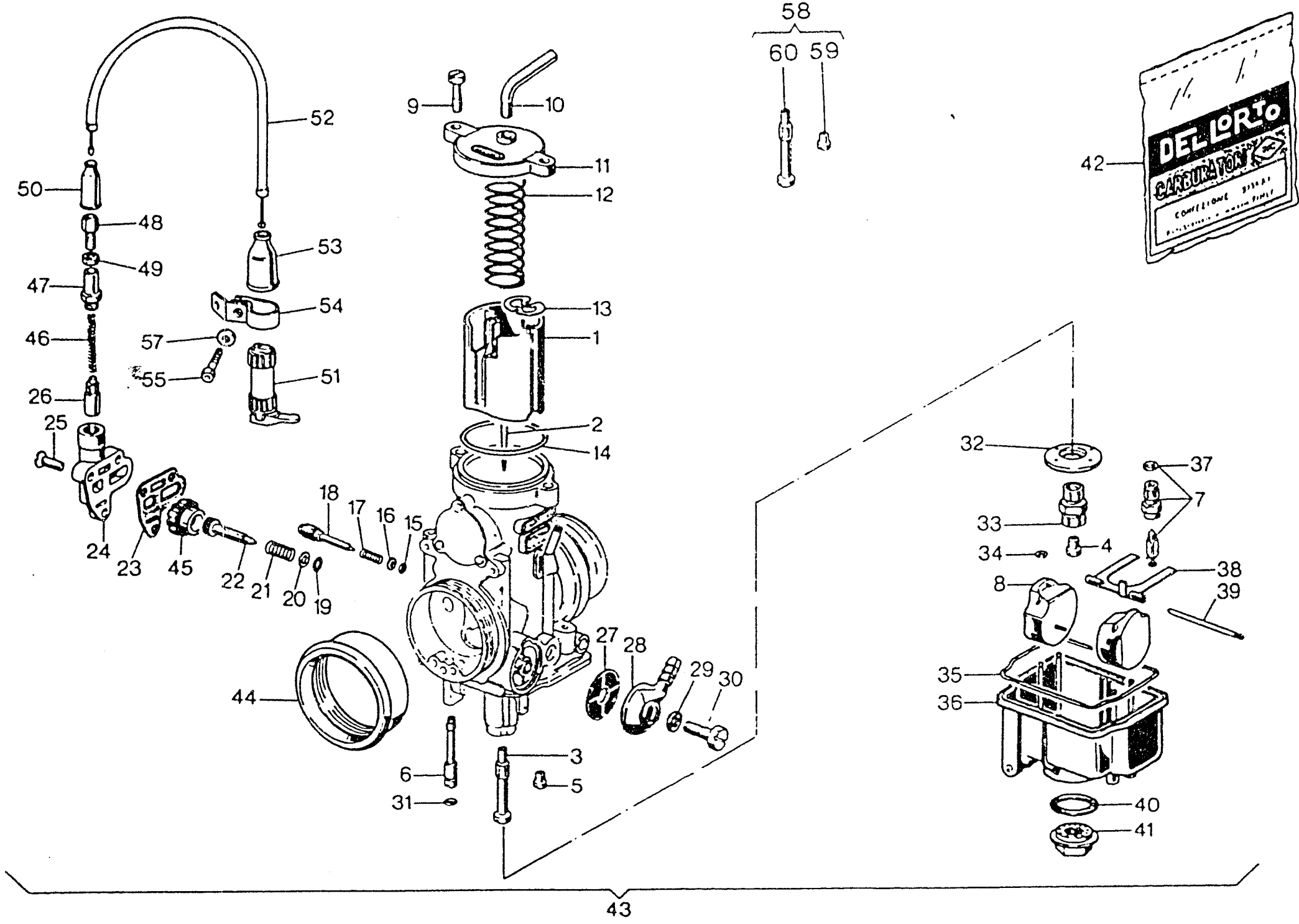



TE - TE U.S.A.
610 / 99

TAVOLA
DRAWING
TABLE
BILD
TABLA

10

CARBURATORE - CARBURETOR
CARBURATEUR - VERGASER
CARBURADOR

Note Notes Notas	Pos. No. N. Index Pos.	N. Cod. Code No. Nr. Code Code Nr N. Cod.	Q.tà Q.ty Q.té M.ge C.ad	DENOMINAZIONE	NAME	DESIGNATION	BESHREIBUNG	DENOMINACION	Validità Validité Gültig Vabdez
	1	8000 60479	1	Valvola gas da 50	Throttle valve 50	Papillon de gaz 50	Drosselklappe 50	Válvula 50	
	2	8000 27910	1	Spillo conico K32	Needle K32	Pointeau conique K32	Kon. Nadel K32	Pasador cónico K32	
	3	8000 24058	1	Polverizzatore 264 AB	Fuel nozzle 264 AB	Pulvérisateur 264 AB	Einspritzdüse 264 AB	Pulverizador 264 AB	
	4	8000 12041	1	Getto massimo 175	Main jet 175	Gicleur principal 175	Hauptdüse 175	Chiclé máximo 175	
	5	8000 05761	1	Getto minimo da 62	Idle jet 62	Gicleur minimum 62	Leerlaufdüse 62	Chiclé mínimo 62	
	6	8000 12032	1	Getto avviamento da 60	Starting jet 60	Gicleur de starter 60	Starterdüse 60	Chiclé arranque 60	
	7	8000 33109	1	Valvola a spillo 300	Needle valve 300	Soupape à pointeau 300	Nadelventil 300	Válvula de aguja 300	
	8	8000 29665	2	Galleggiante g.3,5	Float g.3,5	Flotteur g.3,5	Schwimmer g.3,5	Flotador g.3,5	
	9	8000 23981	2	Vite	Screw	Vis	Schraube	Tomillo	
	10	8000 67457	1	Tubetto	Tube	Tuyau	Rohr	Tube	
	11	8000 60480	1	Coperchio	Cover	Couvercle	Deckel	Tapa	
	12	8000 40578	1	Molla	Spring	Ressort	Feder	Resorte	
	13	8000 23979	1	Fermaglio	Retainer	Arret	Klammer	Abrazadera de sujeción	
	14		1	Guarnizione	Gasket	Garnitue	Dichtung	Junta	
	15		1	Guarnizione	Gasket	Garnitue	Dichtung	Junta	
	16	8000 23985	1	Rosetta piana	Washer	Rondelle	Scheibe	Arandela	
	17	8000 12034	1	Molla	Spring	Ressort	Feder	Resorte	
	18	8000 12033	1	Vite regolazione minimo	Idling mixture adj. screw	Vis réglage mélange de ralenti	Regulierschraube	Tomillo regul. mezcla relenti	
	19		1	Guarnizione	Gasket	Garnitue	Dichtung	Junta	
	20	8000 23983	1	Rosetta piana	Washer	Rondelle	Scheibe	Arandela	
	21	8000 12030	1	Molla	Spring	Ressort	Feder	Resorte	
	22	8000 12029	1	Vite registro valvola gas	Throttle adj. screw	Vis réglage papillons	Drosseleinstellschraube	Tomillo	
	23		1	Guarnizione	Gasket	Garnitue	Dichtung	Junta	
	24	8000 28799	1	Corpo dispositivo avviamento	Starter body	Corps démarrage	Körper Anlass	Cuerpo puesta en marcha	
	25	8000 28798	3	Vite	Screw	Vis	Schraube	Tomillo	
	26	8000 40580	1	Dispositivo avviamento	Starting device	Dispositif de démarrage	Startvorrichtung	Dispositivo puesta en marcha	
	27	8000 12045	1	Filtro benzina	Fuel filter	Filtre essence	Benzinfilter	Filtro gasolina	
	28	8000 12046	1	Pipetta	Pipette	Pipette	Pipette	Pipa	
	29		1	Guarnizione	Gasket	Garnitue	Dichtung	Junta	
	30	8000 12048	1	Vite	Screw	Vis	Schraube	Tomillo	
	31		1	Guarnizione	Gasket	Garnitue	Dichtung	Junta	
	32	8000 32866	1	Fondello	Bottom	Fond	Bodenscheibe	Casquillo	

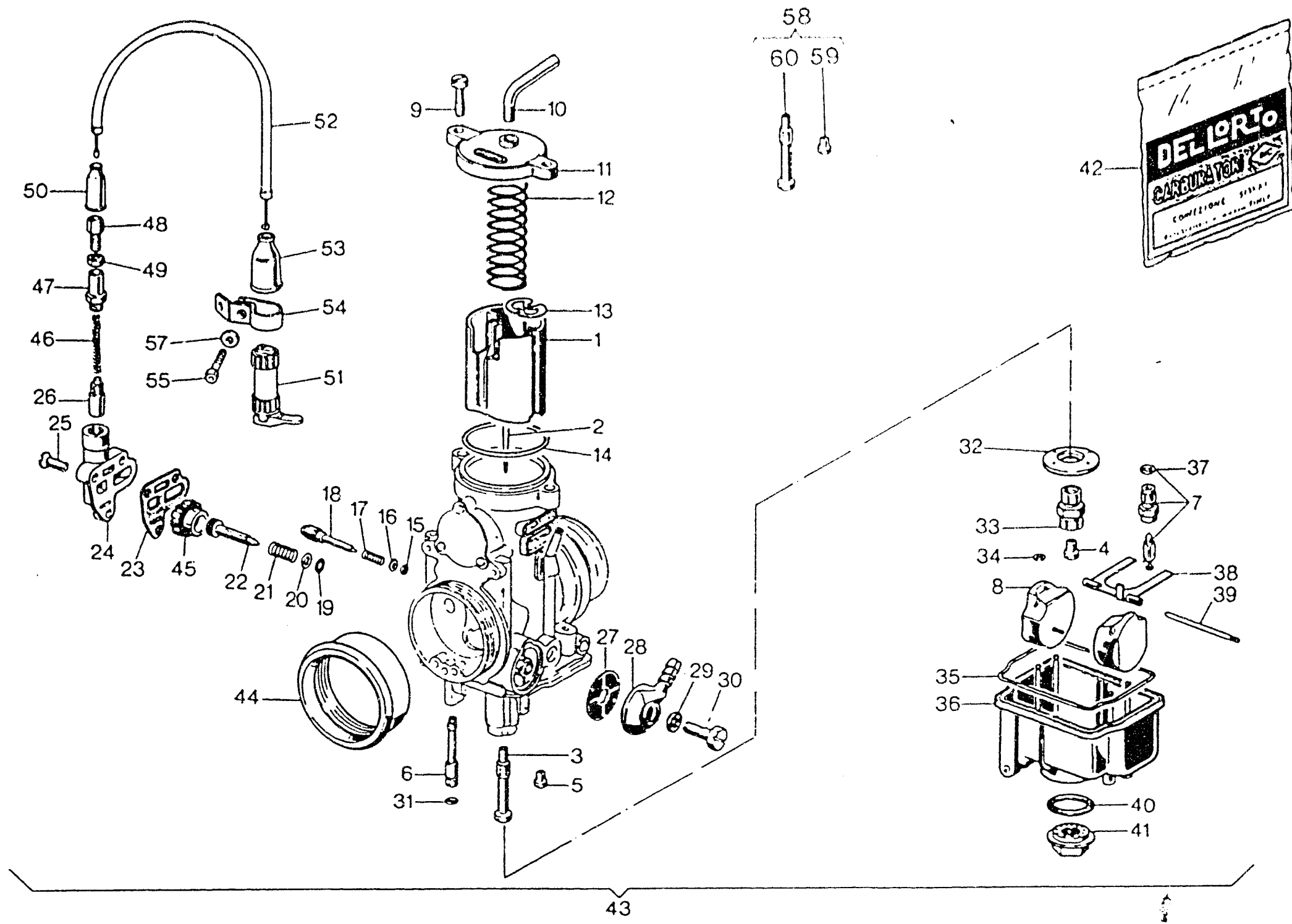



TE - TE U.S.A.
610 / 99

TAVOLA
DRAWING
TABLE
BILD
TABLA

10

CARBURATORE - CARBURETOR
CARBURATEUR - VERGASER
CARBURADOR

Note Notes Notas	Pos. No. Indez. Pos.	N. Cod. Code No. Nr. Code Code Nr N. Cod.	Q. IA Q. ty Q. te M. ge C. ad	DENOMINAZIONE	NAME	DESIGNATION	BESHREIBUNG	DENOMINACION	Validná Validny Validné Gültig Validez
	33	8000 23990	1	Portagetto	Jet-holder	Porte-gicleur	Düsenträger	Porta-chiclé	
	34	8000 32865	2	Fermaglio	Retainer	Arret	Klammer	Abrazadera de sujeción	
I	35		1	Guarnizione	Gasket	Garnitue	Dichtung	Junta	
	36	8000 60502	1	Vaschetta	Chamber	Cuvette	Becken	Cubeta	
I	37		1	Guarnizione	Gasket	Garnitue	Dichtung	Junta	
	38	8000 60501	1	Bilanciere	Rocking lever	Balancier	Schwinge	Balancines	
	39	8000 32867	1	Perno	Pin	Pivot	Bolzen	Perno	
I	40		1	Guarnizione	Gasket	Garnitue	Dichtung	Junta	
	41	8000 33211	1	Tappo	Plug	Bouchon	Verschluss	Tapón	
	42	8000 60504	1	Busta guarnizioni	Gasket set	Jeu joints	Dichtungssatz	Serie juntas	
	43	8A00 67932	1	Carburatore completo	Carburetor assy	Carburateur complet	Vegaser, kpl.	Carburador compl.	
	44	1615 39001	1	Cornetto presa aria	Pipe	Manchon	Muffe	Tubo toma aire	
	45	8000 57413	1	Pomello	Knob	Poignée	Knopf	Pomo	
	46	8000 44043	1	Molla	Spring	Ressort	Feder	Resorte	
	47	8000 67458	1	Tappo	Plug	Bouchon	Verschluss	Tapón	
	48	8000 04103	1	Vite	Screw	Vis	Schraube	Tomillo	
	49	8000 04104	1	Dado	Nut	Ecrou	Mutter	Tuerca	
	50	8000 12451	1	Cappuccio	Cap	Capuchon	Kappe	Capuchón	
	51	8A00 40877	1	Leva comando starter	Lever	Levier	Hebel	Palanca	
	52	8000 67444	1	Trasmissione comando starter	Starter wire	Trasm. comm. starter	Anlassen Kabel	Transm. mando starter	
	53	8000 42980	1	Cappuccio	Cap	Capuchon	Kappe	Capuchón	
	54	8000 67434	1	Staffetta	Bracket	Etrier	Buegel	Brida	
	55	60N1 01048	1	Vite	Screw	Vis	Schraube	Tomillo	
	57	62N1 15503	1	Rosetta	Washer	Rondelle	Scheibe	Arandela	
XR	58	8000 72092	1	Kit omologazione ECE	ECE homologation kit	Gr. homolog. ECE	Ratifikation ECE Gruppe	Kit homologación ECE	
XR	59	80C0 05761	1	Getto minimo da 55	Idle jet 55	Gicleur minimum 55	Leerlaufdüse 55	Chiclé mínimo 55	
XR	60	80C0 24058	1	Polverizzatore 262 AB	Fuel nozzle 262 AB	Pulvérisateur 262 AB	Einspritzdüse 262 AB	Pulverizador 262 AB	
I				Contenuto nella busta guarnizioni Pos.42	Gasket bag No.42	Dans l'enveloppe à joints N 42	mbeutel d. Dichtungen enthalt. Index 42	En el saquito de guarniciones Pos.42	

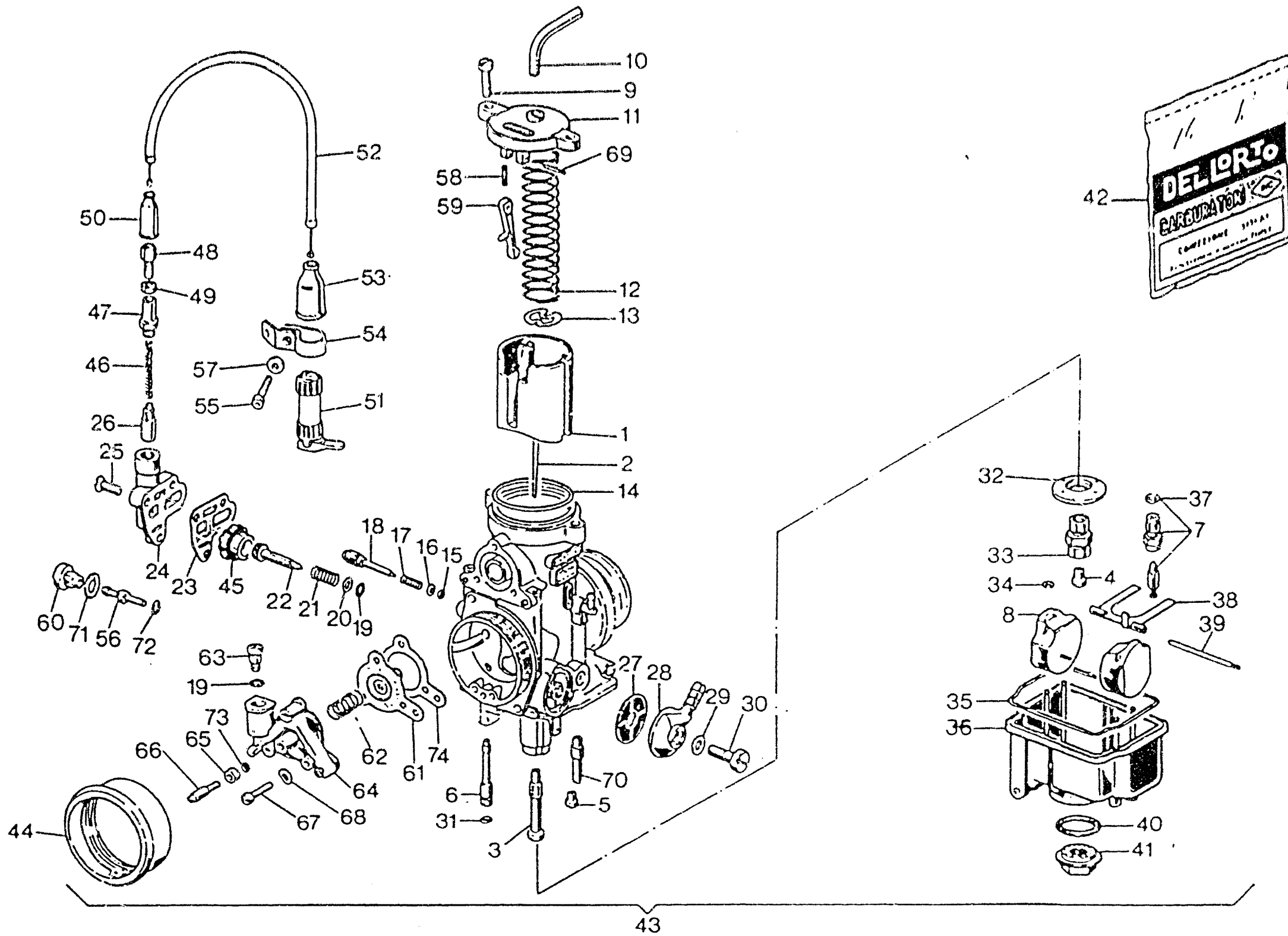



TC 610 / 99

TAVOLA
DRAWING
TABLE
BILD
TABLA

10A

CARBURATORE - CARBURETOR
CARBURATEUR - VERGASER
CARBURADOR

Note Notes Notas	Poe. No. Index Poe.	N. Cod. Code No. Nr. Code Code Nr N. Cod.	Q.tà Q.ty Q.te M.ge C.ad	DENOMINAZIONE	NAME	DESIGNATION	BESCHREIBUNG	DENOMINACION	Validità Validité Validad Gültig Validez
	1	8000 77878	1	Valvola gas da 50	Throttle valve 50	Papillon de gaz 50	Drosselklappe 50	Válvula 50	
	2	8Q00 27910	1	Spillo conico K32	Needle K32	Pointeau conique K32	Kon. Nadel K32	Pasador cónico K32	
	3	8C00 24058	1	Polverizzatore 264 AB	Fuel nozzle 264 AB	Pulvérisateur 264 AB	Einspritzdüse 264 AB	Pulverizador 264 AB	
	4	80U0 12041	1	Getto massimo 170	Main jet 170	Gicleur principal 170	Hauptdüse 170	Chiclé máximo 170	
	5	8GA0 05761	1	Getto minimo da 62	Idle jet 62	Gicleur minimum 62	Leerdüse 62	Chiclé mínimo 62	
	6	80A0 12032	1	Getto avviamento da 60	Starting jet 60	Gicleur de starter 60	Starterdüse 60	Chiclé arranque 60	
	7	8000 33109	1	Valvola a spillo 300	Needle valve 300	Soupape à pointeau 300	Nadelventil 300	Válvula de aguja 300	
	8	8000 29665	2	Galleggiante g.3,5	Float g.3,5	Flotteur g.3,5	Schwimmer g.3,5	Flotador g.3,5	
	9	8000 23981	2	Vite	Screw	Vis	Schraube	Tornillo	
	10	8000 67457	1	Tubetto	Tube	Tuyau	Rohr	Tube	
	11	8000 60480	1	Coperchio	Cover	Couvercle	Deckel	Tapa	
	12	8000 22466	1	Molla	Spring	Ressort	Feder	Resorte	
	13	8000 23979	1	Fermaglio	Retainer	Arret	Klammer	Abrazadera de sujeción	
	14		1	Guarnizione	Gasket	Garnitue	Dichtung	Junta	
	15		1	Guarnizione	Gasket	Garnitue	Dichtung	Junta	
	16	8000 23985	1	Rosetta piana	Washer	Rondelle	Scheibe	Arandela	
	17	8000 12034	1	Molla	Spring	Ressort	Feder	Resorte	
	18	8000 12033	1	Vite regolazione minimo	Idling mixture adj. screw	Vis réglage mélange de ralenti	Regulierschraube	Tornillo regul. mezcla ralenti	
	19		1	Guarnizione	Gasket	Garnitue	Dichtung	Junta	
	20	8000 23983	1	Rosetta piana	Washer	Rondelle	Scheibe	Arandela	
	21	8000 12030	1	Molla	Spring	Ressort	Feder	Resorte	
	22	8000 12029	1	Vite registro valvola gas	Throttle adj. screw	Vis réglage papillons	Drosseleinstellschraube	Tornillo	
	23		1	Guarnizione	Gasket	Garnitue	Dichtung	Junta	
	24	8000 28799	1	Corpo dispositivo avviamento	Starter body	Corps démarrage	Körper Anlass	Cuerpo puesta en marcha	
	25	8000 28798	3	Vite	Screw	Vis	Schraube	Tornillo	
	26	8000 40580	1	Dispositivo avviamento	Starting device	Dispositif de démarrage	Startvorrichtung	Dispositivo puesta en marcha	
	27	8000 12045	1	Filtro benzina	Fuel filter	Filter essence	Benzinfilter	Filtro gasolina	
	28	8000 12046	1	Pipetta	Pipette	Pipette	Pipette	Pipa	
	29		1	Guarnizione	Gasket	Garnitue	Dichtung	Junta	
	30	8000 12048	1	Vite	Screw	Vis	Schraube	Tornillo	
	31		1	Guarnizione	Gasket	Garnitue	Dichtung	Junta	
	32	8000 32866	1	Fondello	Bottom	Fond	Bodenscheibe	Casquillo	

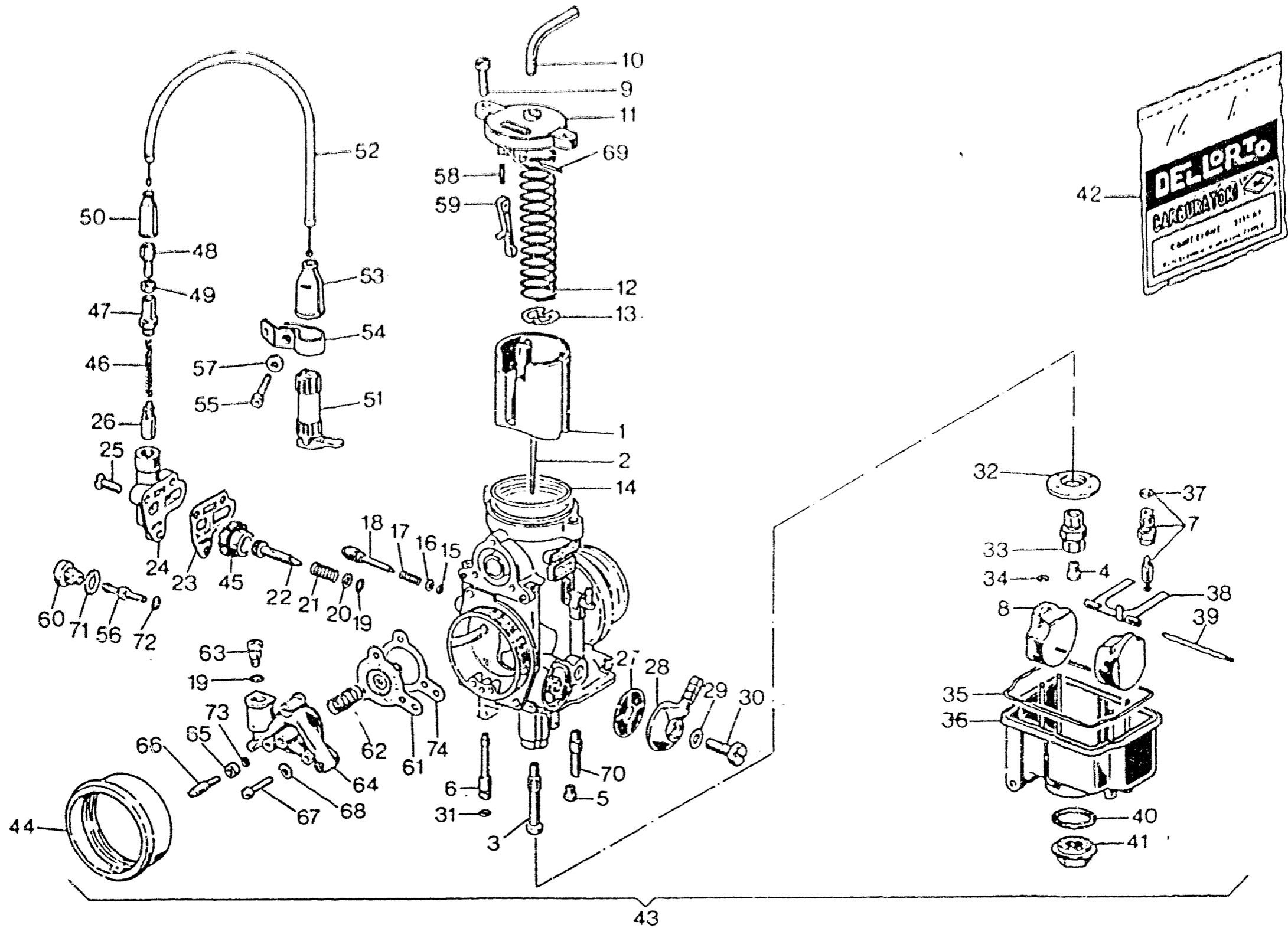



TC 610 / 99

TAVOLA
DRAWING
TABLE
BILD
TABLA

10A

CARBURATORE - CARBURETOR
CARBURATEUR - VERGASER
CARBURADOR

Note Notes Marken Notas	Pos. No. Index Pos.	N. Cod. Code No. Nr. Code Code Nr. N. Cod.	Q.tà Qty Q.té M.ge C.ad	DENOMINAZIONE	NAME	DESIGNATION	BESCHREIBUNG	DENOMINACION	Vertrieb Vertrieb Vertrieb Vertrieb
	33	8000 23990	1	Portagetto	Jet-holder	Porte-gicleur	Düsensträger	Porta-chiclé	
	34	8000 32865	2	Fermaglio	Retainer	Arret	Klammer	Abrazadera de sujeción	
I	35		1	Guarnizione	Gasket	Garniture	Dichtung	Junta	
	36	8000 60502	1	Vaschetta	Chamber	Cuvette	Becken	Cubeta	
I	37		1	Guarnizione	Gasket	Garniture	Dichtung	Junta	
	38	8000 60501	1	Bilanciere	Rocking lever	Balancier	Schwinge	Balancines	
	39	8000 32867	1	Perno	Pin	Pivot	Bolzen	Perno	
I	40		1	Guarnizione	Gasket	Garniture	Dichtung	Junta	
	41	8000 33211	1	Tappo	Plug	Bouchon	Verschluss	Tapón	
	42	8000 77879	1	Busta guarnizioni	Gasket set	Jeu joints	Dichtungssatz	Sete juntas	
	43	8000 75847	1	Carburatore completo	Carburetor assy	Carburateur complet	Vergaser, kpl.	Carburador compl.	
	44	1615 39001	1	Cometto presa aria	Pipe	Manchon	Muffe	Tubo toma aire	
	45	8000 57413	1	Pomello	Knob	Poignée	Knopf	Pomo	
	46	8000 44043	1	Molla	Spring	Ressort	Feder	Resorte	
	47	8000 67458	1	Tappo	Plug	Bouchon	Verschluss	Tapón	
	48	8000 04103	1	Vite	Screw	Vis	Schraube	Tornillo	
	49	8000 04104	1	Dado	Nut	Ecrou	Mutter	Tuerca	
	50	8000 12451	1	Cappuccio	Cap	Capuchon	Kappe	Capuchón	
	51	8A00 40877	1	Leva comando starter	Lever	Levier	Hebel	Palanca	
	52	8000 67444	1	Trasmissione comando starter	Starter wire	Trasm. comm. starter	Anlassen Kabel	Transm. mando starter	
	53	8000 42980	1	Cappuccio	Cap	Capuchon	Kappe	Capuchón	
	54	8000 67434	1	Staffetta	Bracket	Etrier	Buegel	Brida	
	55	60N1 01048	1	Vite	Screw	Vis	Schraube	Tornillo	
	56	80B0 40596	1	Getto pompa 48	Pump jet 48	Gicleur pompe 48	Pumpendüse 48	Chiclé bomba 48	
	57	62N1 15503	1	Rosetta	Washer	Rondelle	Scheibe	Arandela	
	58	8000 40586	1	Molla	Spring	Ressort	Feder	Resorte	
	59	8000 42955	1	Leva coman. pompa	Lever	Levier	Hebel	Palanca	
	60	8000 40597	1	Portagetto	Jet-holder	Porte-gicleur	Düsensträger	Porta-chiclé	
	61	8000 40593	1	Membrana pompa	Pump diaphragm	Diaphragme pompe	Pumpenmembrane	Membrana bomba	
	62	8000 40594	1	Molla	Spring	Ressort	Feder	Resorte	
	63	8000 40595	1	Valvola mandata pompa	Pump del. valve	Soupape réfoul. pompe	Pumpendruckventil	Válvula envío bomba	
	64	8000 40588	1	Coperchio	Cover	Couvercle	Deckel	Tapa	

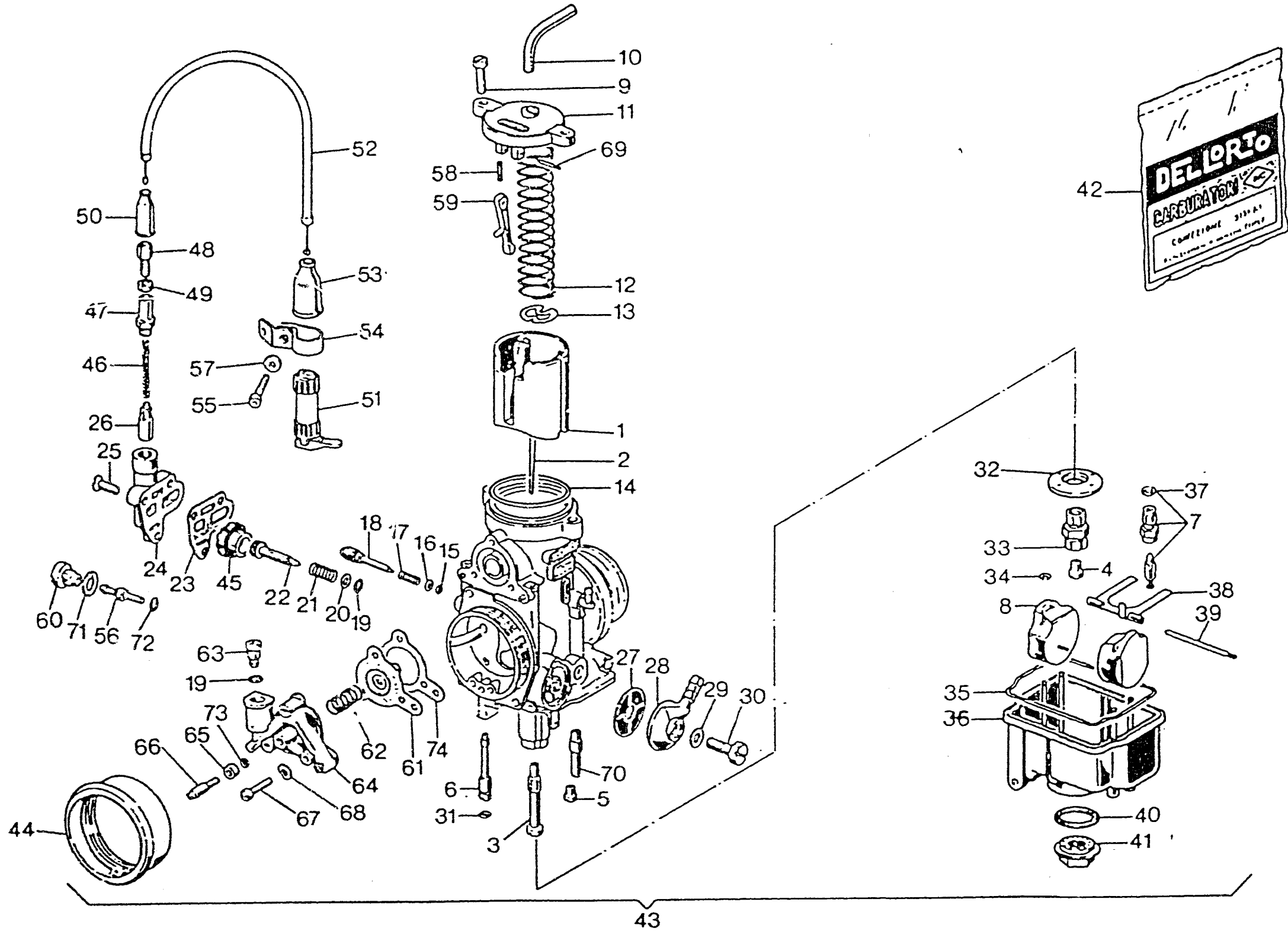



TC 610 / 99

TAVOLA
DRAWING
TABLE
BILD
TABLA

10A

CARBURATORE - CARBURETOR
CARBURATEUR - VERGASER
CARBURADOR

Note Notes Notas	Pos. No. N. Index Pos.	N. Cod. Code No. Nr. Code Code Nr N. Cod.	Q.tà Q.ty Q.té M.ge C.ad	DENOMINAZIONE	NAME	DESIGNATION	BESHREIBUNG	DENOMINACION	Validità Validity Gültig Validez
	65	8000 40592	1	Dado	Nut	Ecrou	Mutter	Tuerca	
	66	8000 40591	1	Vite	Screw	Vis	Schraube	Tornillo	
	67	8000 40589	3	Vite	Screw	Vis	Schraube	Tornillo	
	68	8000 40590	3	Rosetta	Washer	Rondelle	Scheibe	Arandela	
	69	8000 40587	1	Perno leva coman. pompa	Pin	Pivot	Bolzen	Perno	
	70	8000 40584	1	Valvola aspirazione	Inlet valve	Soupape admission	Einlass-Ventil	Válvula aspiración	
	71		1	Guarnizione	Gasket	Garnitue	Dichtung	Junta	
	72		1	Guarnizione	Gasket	Garnitue	Dichtung	Junta	
	73		1	Guarnizione	Gasket	Garnitue	Dichtung	Junta	
	74		1	Guarnizione	Gasket	Garnitue	Dichtung	Junta	
				Contenuto nella busta guarnizioni Pos.42	Gasket bag No.42	Dans l'enveloppe à joints N 42	Imbeutel d. Dichtungen enthalt. Index 42	En el saquito de guarniciones Pos.42	

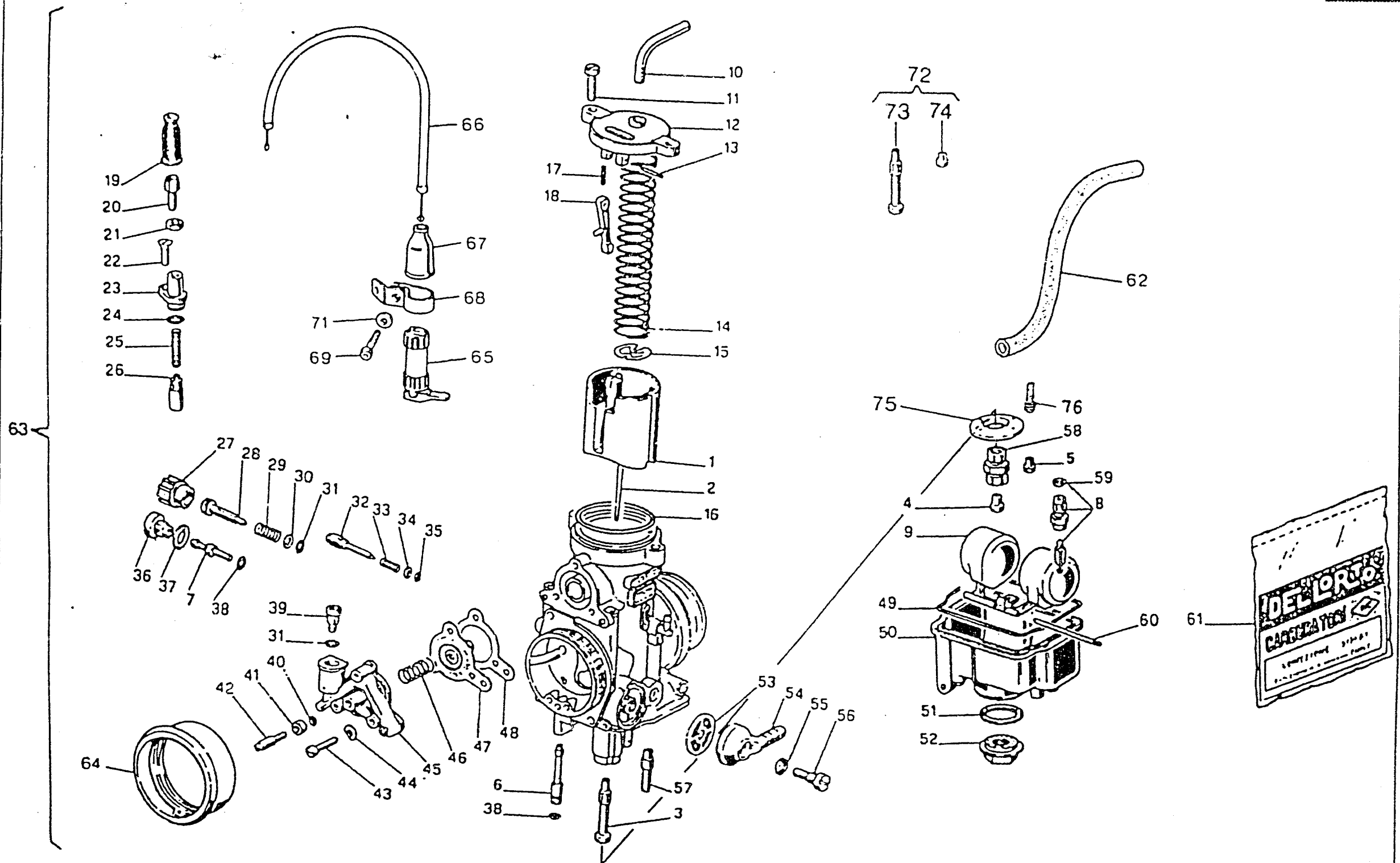



TE - TE U.S.A.
410 / 99

TAVOLA
DRAWING
TABLE
BILD
TABLA

10B

CARBURATORE - CARBURETOR
CARBURATEUR - VERGASER
CARBURADOR

Note Notes Marka Notas	Pos. No. N. Index Pos.	N. Cod. Code No. Nr. Code Code Nr N. Cod.	Q.tà Q.ty Q.te M.ge C.ad	DENOMINAZIONE	NAME	DESIGNATION	BESHREIBUNG	DE-NOMINACION	Validità Validity Validité Gültig Validez
	1	8A00 55248	1	Valvola gas 40/3	Throttle valve 40/3	Papillon de gaz 40/3	Drosselklappe 40/3	Válvula 40/3	
	2	8Q00 27910	1	Spillo conico K32 (3ª tacca)	Needle K32/3	Pointeau conique K32/3	Kon. Nadel K32/3	Pasador cónico K32/3	
	3	8000 24058	1	Polverizzatore 258 AB	Fuel nozzle 258 AB	Pulvérisateur 258 AB	Einspritzdüse 258 AB	Pulverizador 258 AB	
	4	80U0 12041	1	Getto massimo 170	Main jet 170	Gicleur principal 170	Hauptdüse 170	Chiclé máximo 170	
D	4	8PLO 12041	1	Getto massimo 158	Main jet 158	Gicleur principal 158	Hauptdüse 158	Chiclé máximo 158	
	5	80F0 05761	1	Getto minimo 58	Idle jet 58	Gicleur minimum 58	Leerlaufdüse 58	Chiclé mínimo 58	
D	5	8B00 87148	1	Getto minimo 60	Idle jet 60	Gicleur minimum 60	Leerlaufdüse 60	Chiclé mínimo 60	
	6	80H0 12032	1	Getto avviamento 45	Starting jet 45	Gicleur de starter 45	Starterdüse 45	Chiclé arranque 45	
	7	8000 40596	1	Getto pompa 35	Pump jet 35	Gicleur pompe 35	Pumpendüse 35	Chiclé bomba 35	
	8	8000 25117	1	Valvola a spillo 250	Needle valve 250	Soupape à pointeau 250	Nadelventil 250	Válvula de aguja 250	
	9	8000 34128	1	Galleggiante gr.12,5	Float gr.12,5	Flotteur gr.12,5	Schwimmer gr.12,5	Flotador gr.12,5	
	10	8000 67457	1	Tubetto	Tube	Tuyau	Rohr	Tubo	
	11	8000 23981	2	Vite	Screw	Vis	Schraube	Tomillo	
	12	8000 40579	1	Coperchio	Cover	Couvercle	Deckel	Tapa	
	13	8000 40587	1	Perno leva coman. pompa	Pin	Pivot	Bolzen	Perno	
	14	8000 35086	1	Molla	Spring	Ressort	Feder	Resorte	
	15	8000 23979	1	Fermaglio	Retainer	Arret	Klammer	Abrazadera de sujeción	
	16	I	1	Guarnizione	Gasket	Garnitue	Dichtung	Junta	
	17	8000 40586	1	Molla	Spring	Ressort	Feder	Resorte	
	18	8000 40585	1	Leva coman. pompa	Lever	Levier	Hebel	Palanca	
	19	8000 12451	1	Cappuccio	Cap	Capuchon	Kappe	Capuchón	
	20	8000 04103	1	Vite	Screw	Vis	Schraube	Tomillo	
	21	8000 04104	1	Dado	Nut	Ecrou	Mutter	Tuerca	
	22	8000 32855	1	Vite	Screw	Vis	Schraube	Tomillo	
	23	8000 40582	1	Coperchio	Cover	Couvercle	Deckel	Tapa	
	24	I	1	Guarnizione	Gasket	Garnitue	Dichtung	Junta	
	25	8000 40581	1	Molla	Spring	Ressort	Feder	Resorte	
	26	8000 40580	1	Dispositivo avviamento	Starting device	Dispositif de démarrage	Startvorrichtung	Dispositivo puesta en marcha	
	27	8000 57413	1	Pomello	Knob	Poignée	Knopf	Pomo	
	28	8000 12029	1	Vite	Screw	Vis	Schraube	Tomillo	
	29	8000 12030	1	Molla	Spring	Ressort	Feder	Resorte	
	30	8000 23983	1	Rosetta	Washer	Rondelle	Scheibe	Arandela	

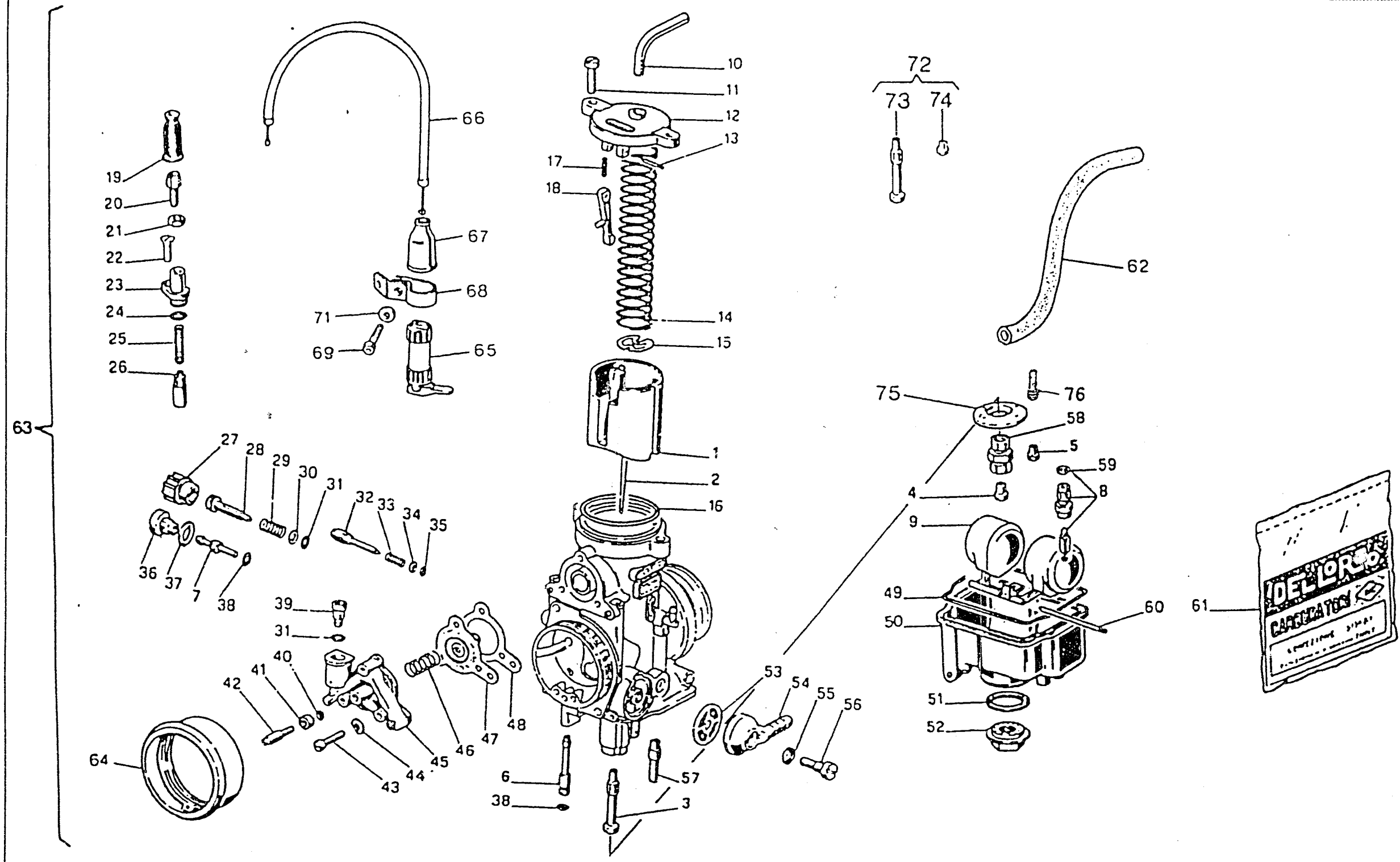



TE - TE U.S.A.
410 / 99

TAVOLA
DRAWING
TABLE
BILD
TABLA

10B

CARBURATORE - CARBURETOR
CARBURATEUR - VERGASER
CARBURADOR

Note Notes Marka Notas	Pos. No. N. Index Pos.	N. Cod. Code No. Nr. Code Code Nr N. Cod.	Q.ia Q.ty Q.te M.ge C.ad	DENOMINAZIONE	NAME	DESIGNATION	BESHREIBUNG	DENOMINACION	Validità Validité Gültig Validez
	31	I	1	Guarnizione	Gasket	Garnitue	Dichtung	Junta	
	32	8000 40620	1	Vite regolazione minimo	Idling mixture adj. screw	Vis réglage mélange de ralenti	Regulierschraube	Tomillo regul. mezcla relenti	
	33	8000 12034	1	Molla	Spring	Ressort	Feder	Resorte	
	34	8000 23985	1	Rosetta	Washer	Rondelle	Scheibe	Arandela	
	35	I	1	Guarnizione	Gasket	Garnitue	Dichtung	Junta	
	36	8000 40597	1	Portagetto	Jet-holder	Porte-gicleur	Düsenträger	Porta-chiclé	
	37	i	1	Guarnizione	Gasket	Garnitue	Dichtung	Junta	
	38	I	1	Guarnizione	Gasket	Garnitue	Dichtung	Junta	
	39	8000 40595	1	Valvola mandata pompa	Pump del. valve	Soupape réfoul. pompe	Pumpendruckventil	Válvula envío bomba	
	40	I	1	Guarnizione	Gasket	Garnitue	Dichtung	Junta	
	41	8000 40592	1	Dado	Nut	Ecrou	Mutter	Tuerca	
	42	8000 40591	1	Vite	Screw	Vis	Schraube	Tomillo	
	43	8000 40589	3	Vite	Screw	Vis	Schraube	Tomillo	
	44	8000 40590	3	Rosetta	Washer	Rondelle	Scheibe	Arandela	
	45	8000 40588	1	Coperchio	Cover	Couvercle	Deckel	Tapa	
	46	8000 40594	1	Molla	Spring	Ressort	Feder	Resorte	
	47	8000 40593	1	Membrana pompa	Pump diaphragm	Diaphragme pompe	Pumpenmembrane	Membrana bomba	
	48	I	1	Guarnizione	Gasket	Garnitue	Dichtung	Junta	
	49	I	1	Guarnizione	Gasket	Garnitue	Dichtung	Junta	
	50	8000 36500	1	Vaschetta	Chamber	Cuvette	Becken	Cubeta	
	51	I	1	Guarnizione	Gasket	Garnitue	Dichtung	Junta	
	52	8000 33211	1	Tappo	Plug	Bouchon	Verschluss	Tapón	
	53	8000 12045	1	Filtro benzina	Fuel filter	Filtre essence	Benzinfilter	Filtro gasolina	
	54	8000 12046	1	Pipetta	Pipette	Pipette	Pipette	Pipa	
	55	I	1	Guarnizione	Gasket	Garnitue	Dichtung	Junta	
	56	8000 12048	1	Vite	Screw	Vis	Schraube	Tomillo	
	57	8000 40584	1	Valvola aspirazione	Inlet valve	Soupape admission	Einlass-Ventil	Válvula aspiración	
	58	8000 23990	1	Portagetto	Jet-holder	Porte-gicleur	Düsenträger	Porta-chiclé	
	59	I	1	Guarnizione	Gasket	Garnitue	Dichtung	Junta	
	60	8000 32867	1	Perno	Pin	Pivot	Bolzen	Perno	
	61	8000 68110	1	Busta guarnizioni	Gasket set	Jeu joints	Dichtungssatz	Serie juntas	
	62	8000 67498	1	Tube sfianto	Tube	Tuyau	Rohr	Tube	

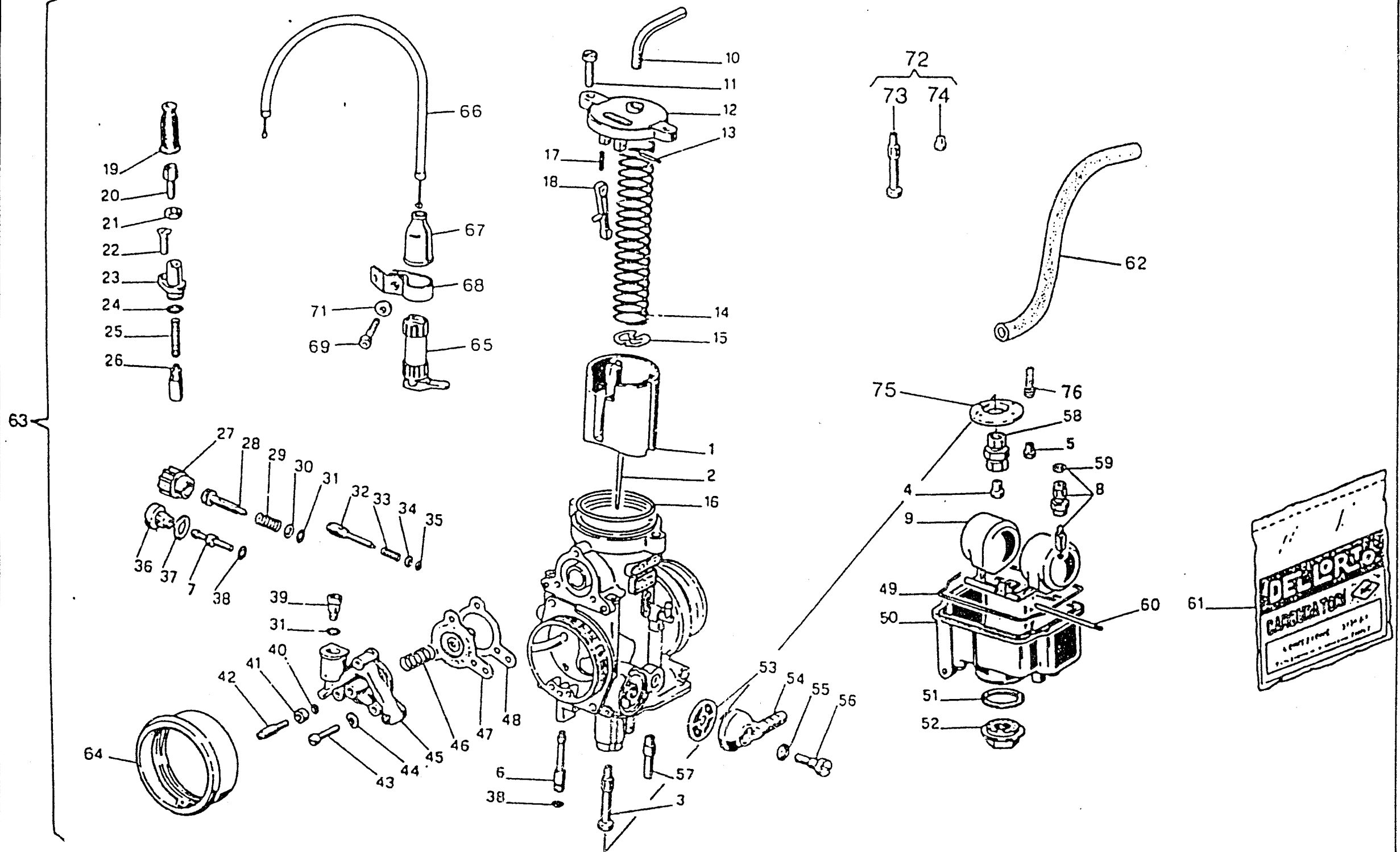



TE - TE U.S.A.
410 / 99

TAVOLA
DRAWING
TABLE
BILD
TABLA

103

CARBURATORE - CARBURETOR
CARBURATEUR - VERGASER
CARBURADOR

Note Notes Marka Notas	Pos. No. N. Index Pos.	N. Cod. Code No. Nr. Code Code Nr N. Cod.	Q.tà Q.ty Q.té M.ge C.ad	DENOMINAZIONE	NAME	DESIGNATION	BESHREIBUNG	DENOMINACION	Validità Validity Validité Gültig Validez
	63	8000 82044	1	Carburatore completo	Carburetor assy	Carburateur complet	Vegaser, kpl.	Carburador compl.	
	64	8000 63655	1	Cornetto presa aria	Pipe	Manchon	Muffe	Tubo toma aire	
	65	8A00 40877	1	Leva comando starter	Lever	Levier	Hebel	Palanca	
	66	8A00 67444	1	Trasmissione comando starter	Starter wire	Trasm. comm. starter	Anlassen Kabel	Transm. mando starter	
	67	8000 42980	1	Cappuccio	Cap	Capuchon	Kappe	Capuchón	
	68	8000 67434	1	Staffetta	Bracket	Etrier	Buegel	Brida	
		60N1 01048	1	Vite	Screw	Vis	Schraube	Tomillo	
	/1	62N1 15503	1	Rosetta	Washer	Rondelle	Scheibe	Arandela	
R	72	8000 72092	1	Kit omologazione ECE	ECE homologation kit	Gr. homolog. ECE	Ratifikation ECE Gruppe	Kit homologación ECE	
R	73	80C0 24058	1	Polverizzatore 262 AB	Fuel nozzle	Pulvérisateur	Einspritzdüse	Pulverizador	
R	74	80C0 05761	1	Getto minimo 55	Idle jet	Gicleur minimum	Leerlaufdüse	Chiclé mínimo	
	75	8000 32866	1	Fondello	Bottom	Fond	Bodenscheibe	Casquillo	
D	76	80B0 63846	1	Emulsionatore minimo	Emulsifier	Emulsionneur	Mischer	Emulsionador	
I				Contenuto nella busta guarnizioni Pos.61	Gasket bag No.61	Dans l'enveloppe à joints N 61	Imbeutel d. Dichtungen enthalt. Index 61	En el saquito de guarniciones Pos.61	

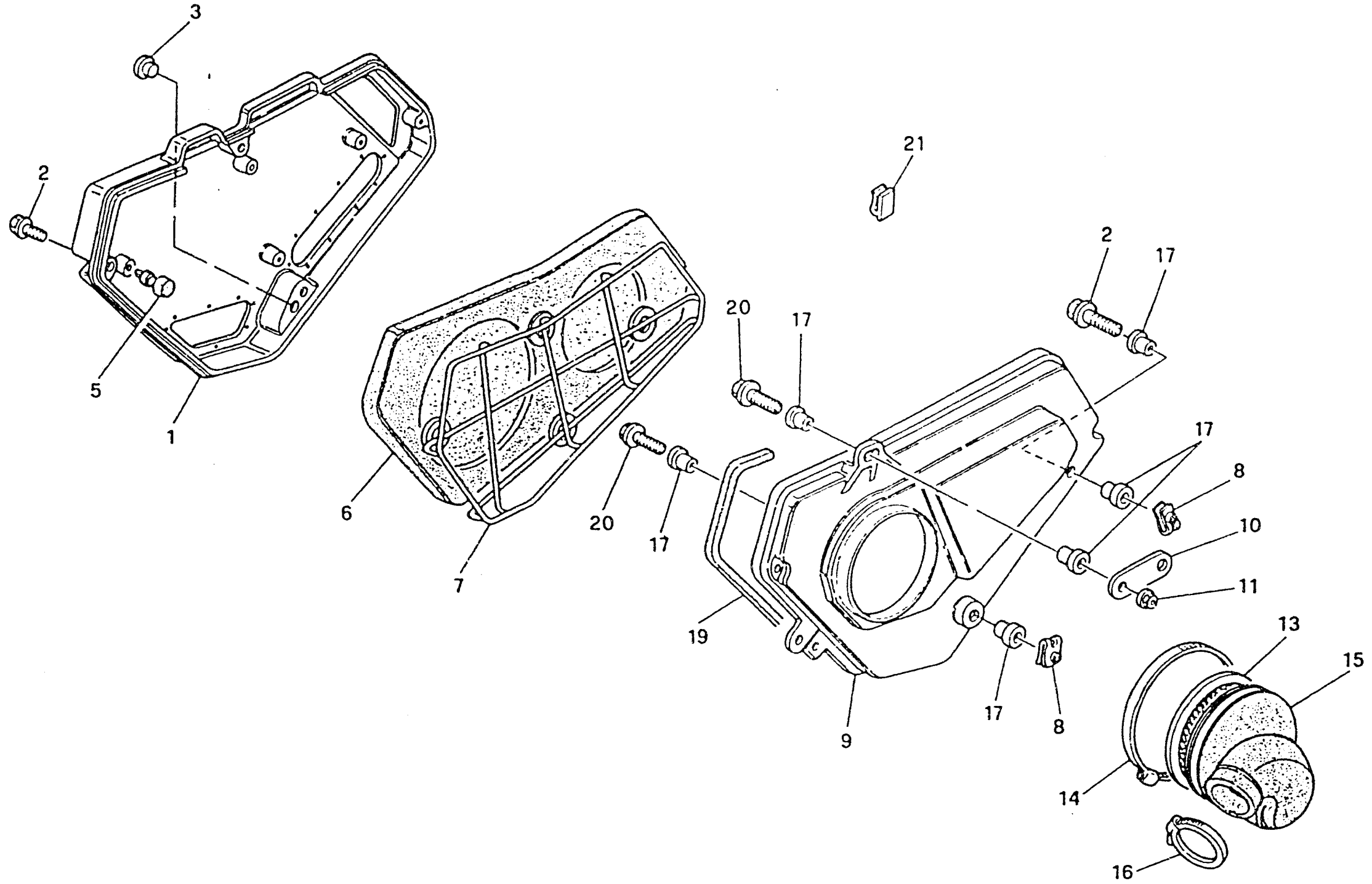



TE - TE U.S.A.
410 - 610 / 99
TC 610 / 99

TAVOLA
DRAWING
TABLE
BILD
TABLA

11

FILTRO ARIA - AIR FILTER
FILTRE AIRE - AIRFILTER
FILTRO DE AIRE

Note Notes Mark Notas	Pos. No. Index Pos.	N. Cod. Code No. Nr. Code Code Nr N. Cod.	Q.tà Q.ty Q.te M.ge C.ad	DENOMINAZIONE	NAME	DESIGNATION	BESHREIBUNG	DENOMINACION	Valida Validty Validé Gültig Validez
	1	8A00 69782	1	Coperchio	Cover	Couvercle	Deckel	Tapa	
	2	8000 62727	2	Vite	Screw	Vis	Schraube	Tornillo	
	3	8000 55101	1	Tappo	Plug	Bouchon	Verschluss	Tapón	
	5	8000 67970	1	Tampone	Pad	Tampon	Stopfen	Tampón	
	6	8000 69783	1	Filtro aria	Air filter	Filtre à air	Luftfilter	Filtro aire	
	7	8000 69784	1	Gabbia filtro	Cleaner cage	Cage pour filtre	Filterkafig	Caja filtro	
	8	8000 46893	2	Dado	Nut	Ecrou	Mutter	Tuerca	
	9	80A0 75671	1	Scatola filtro	Air filter box	Boîte filtre	Filterkasten	Caja filtro aire	
	10	1515 80301	1	Piastrina	Plate	Plaque	Plättchen	Placa	
	11	8000 44240	1	Dado	Nut	Ecrou	Mutter	Tuerca	
	13	8000 75673	1	Protezione	Guard	Protection	Schutz	Protección	
	14	8F00 56515	1	Fascetta	Clamp	Collier	Schelle	Banda	
	15	8000 75672	1	Raccordo	Union	Raccord	Anschluss	Empalme	
	16	8000 37906	1	Fascetta	Clamp	Collier	Schelle	Banda	
	17	8000 45495	3	Bussola	Bushing	Douille	Buchse	Manguito	
	19	8A00 60652	1	Guarnizione	Gasket	Garnitue	Dichtung	Junta	
	20	8000 62728	4	Vite	Screw	Vis	Schraube	Tornillo	
	21	8000 56806	1	Gancio adesivo	Hook	Crochet	Haken	Gancho	

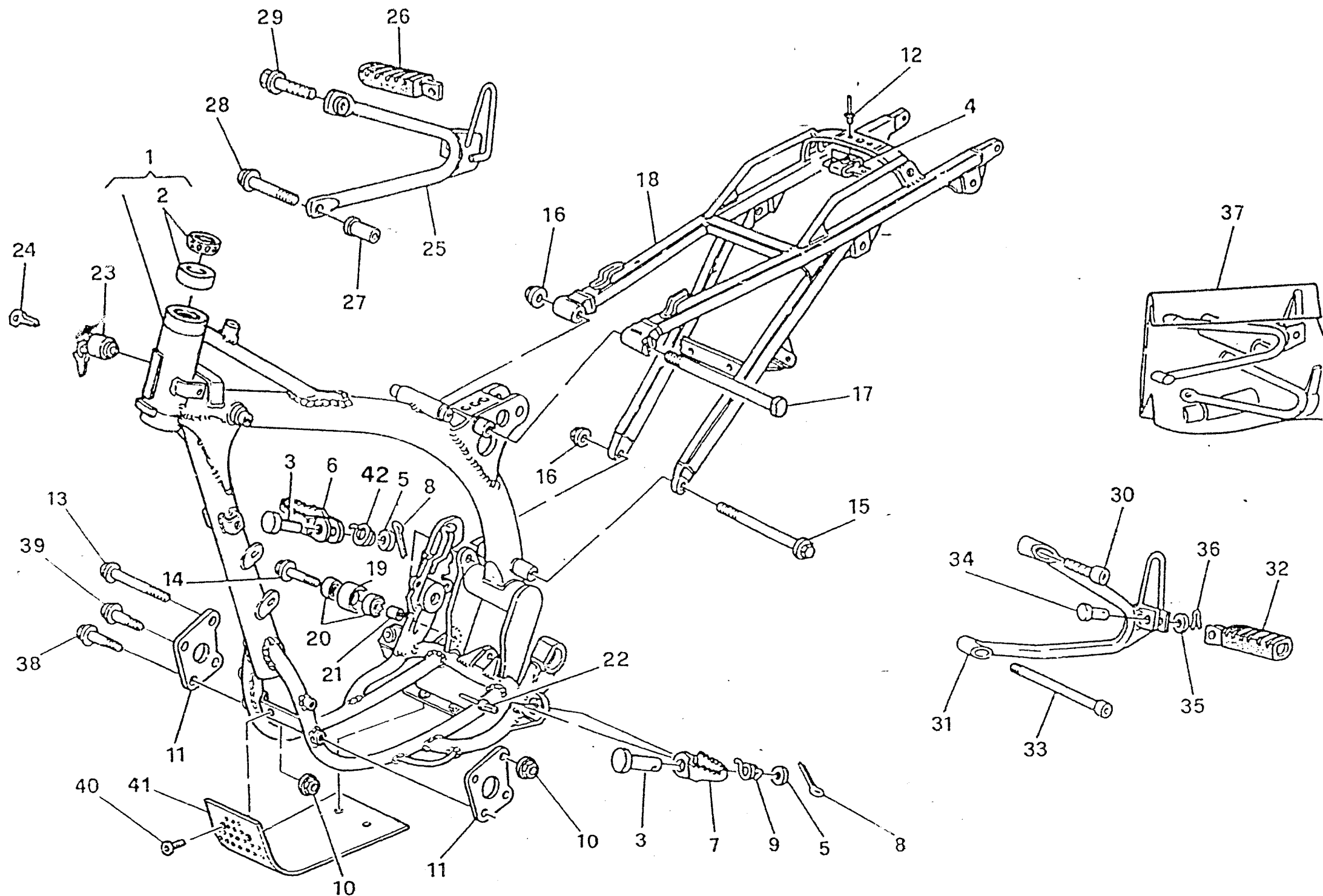



TE - TE U.S.A.
410 - 610 / 99
TC 610 / 99

TAVOLA
DRAWING
TABLE
BILD
TABLA

12

TELAIO, PEDANE - FRAME, FOOT RESTS
CADRE, REPOSE PIEDS - RAHMEN, FUSSBRETT
BASTIDOR, REPOSAPIES

Note Notes Marka Notas	Pos. No. N. Index Pos.	N. Cod. Code No. Nr. Code Code Nr N. Cod.	Q.tà Q.ty Q.te M.ge C.ad	DENOMINAZIONE	NAME	DESIGNATION	BESHREIBUNG	DENOMINACION	Validità Validity Validité Gültig Validez
W	1	8A00 90111	1	Telaio	Frame	Chassis	Rahmen	Bastidor	
U	1	8E00 90111	1	Telaio	Frame	Chassis	Rahmen	Bastidor	
C	1	8A00 90170	1	Telaio	Frame	Chassis	Rahmen	Bastidor	
WU	2	1513 07001	2	Cuscinetto	Bearing	Roulement	Lager	Cojinete	
C	2	8000 87243	2	Cuscinetto	Bearing	Roulement	Lager	Cojinete	
	3	8000 73140	2	Perno	Pin	Pivot	Bolzen	Perno	
	4	8000 69150	1	Piastrina	Plate	Plaquette	Plättchen	Placa	
	5	62N1 15507	2	Rosetta	Washer	Rondelle	Scheibe	Arandela	
	6	80A0 89953	1	Poggiapiedi Dx.	R.H. foot rest support	Support repose pied D.	R., Fussraster	Prisioneros derech. compl.	
	7	80A0 89962	1	Poggiapiedi Sx.	L.H. foot rest support	Support repose pied G.	L., Fussraster	Prisioneros compl.	
	8	64N1 20068	2	Copiglia	Split pin	Goupille	Splint	Clavija	
	9	8000 89882	1	Molla Dx	R.H. spring	Ressort D.	Feder Rechte	Resorte der.	
	10	80B0 43928	6	Dado	Nut	Ecrou	Mutter	Tuerca	
	11	8000 84665	2	Piastra motore	Motor plate	Plaquette moteur	Motorplättchen	Placa motor	
	12	8000 33373	2	Rivetto	Rivet	Rivet	Niet	Remache	
	13	8000 80277	2	Vite	Screw	Vis	Schraube	Tornillo	
	14	8000 62796	2	Vite	Screw	Vis	Schraube	Tornillo	
	15	8C00 69112	1	Vite	Screw	Vis	Schraube	Tornillo	
	16	8000 43928	2	Dado	Nut	Ecrou	Mutter	Tuerca	
	17	8000 69111	1	Vite	Screw	Vis	Schraube	Tornillo	
W	18	8000 75800	1	Telaio posteriore	Rear frame side	Chassis arrière	Sattelbrücke	Cuadro posterior	
CU	18	8000 75801	1	Telaio posteriore	Rear frame side	Chassis arrière	Sattelbrücke	Cuadro posterior	
	19	8000 59433	2	Rullo	Roller	Aiguille	Rolle	Rodillo	
	20	8000 63312	4	Cuscinetto	Bearing	Roulement	Lager	Cojinete	
	21	8000 59434	2	Distanziale	Spacer	Entretoise	Distanzstück	Separador	
	22	8000 41922	2	Rivetto	Rivet	Rivet	Niet	Remache	
XY	23	8000 43391	1	Serratura antifurto	Anti-left lock assy	Serrure anti-vol compl.	Sicherheitsschloss kpl.	Cerradura compl.	
XY	24	8000 35531	1	Chiave grezza	Raw key	Clef primitive	Schlüssel	Llave	
XYD	25	80A0 67720	1	Supp. poggia piedi Passegg. Dx.	Support	Support	Halterung	Soporte elástico	
XYD	26	8000 66652	1	Poggiapiedi passeggero Dx.	R.H. foot rest support	Support repose pied D.	R., Fussraster	Prisioneros derech. compl.	
XYD	27	8000 67724	1	Distanziale	Spacer	Entretoise	Distanzstück	Separador	
XYD	28	8A00 62797	1	Vite	Screw	Vis	Schraube	Tornillo	

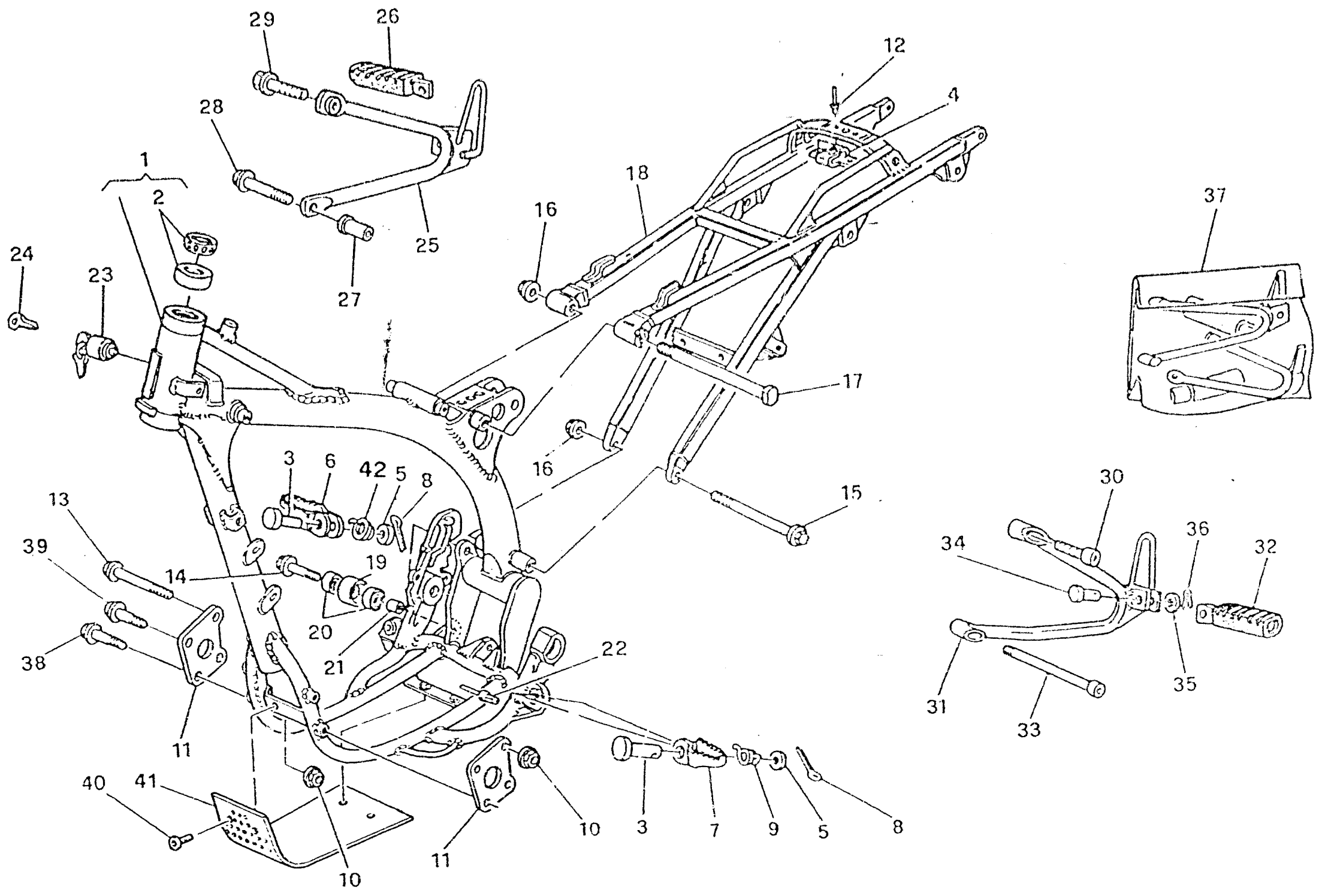



TE - TE U.S.A.
410 - 610 / 99
TC 610 / 99

TAVOLA
DRAWING
TABLE
BILD
TABLA

12

TELAIO, PEDANE - FRAME, FOOT RESTS
CADRE, REPOSE PIEDS - RAHMEN, FUSSBRETT
BASTIDOR, REPOSAPIES

Note Notes Merke Notas	Pos. No. Index Pos.	N. Cod. Code No. Nr. Code Code Nr N. Cod.	Q.tà Qty Q.té M.ge C.ad	DENOMINAZIONE	NAME	DESIGNATION	BESHREIBUNG	DENOMINACION	Validrà Vaidrà Gültig Validez
XYD	29	8000 69056	2	Vite	Screw	Vis	Schraube	Tornillo	
XYD	30	60N1 02555	1	Vite	Screw	Vis	Schraube	Tornillo	
XYD	31	80A0 78265	1	Supp. poggiapiedi passeg. Sx.	Support	Support	Halterung	Soporte elástico	
XYD	32	8000 66651	1	Poggiapiedi passeggero Sx.	L.H. foot rest support	Support repose pied G.	L., Fussraster	Prisioneros compl.	
XYD	33	8000 62727	1	Vite	Screw	Vis	Schraube	Tornillo	
XYD	34	8000 41459	2	Perno	Pin	Pivot	Bolzen	Perno	
XYD	35	62N1 15504	2	Rosetta piana	Washer	Rondelle	Scheibe	Arandela	
XYD	36	64N1 20048	2	Copiglia	Split pin	Goupille	Splint	Clavija	
XYD	37	8A00 78447	1	Kit poggiapiedi passeggero	L.H. foot rest support kit	Gr. support repose pied G.	L., Fussraster Gruppe	Kit prisioneros compl.	
D	38	8E00 69056	2	Vite	Screw	Vis	Schraube	Tornillo	
D	39	8000 62795	2	Vite	Screw	Vis	Schraube	Tornillo	
D	40	8000 60896	4	Vite	Screw	Vis	Schraube	Tornillo	
D	41	8000 88143	1	Paramotore	Engine guard	Garde moteur	Motorschutz	Para motor	
	42	8A00 89382	1	Molla Sx	L.H. spring	Ressort G.	Feder Linke	Resorte iz.	

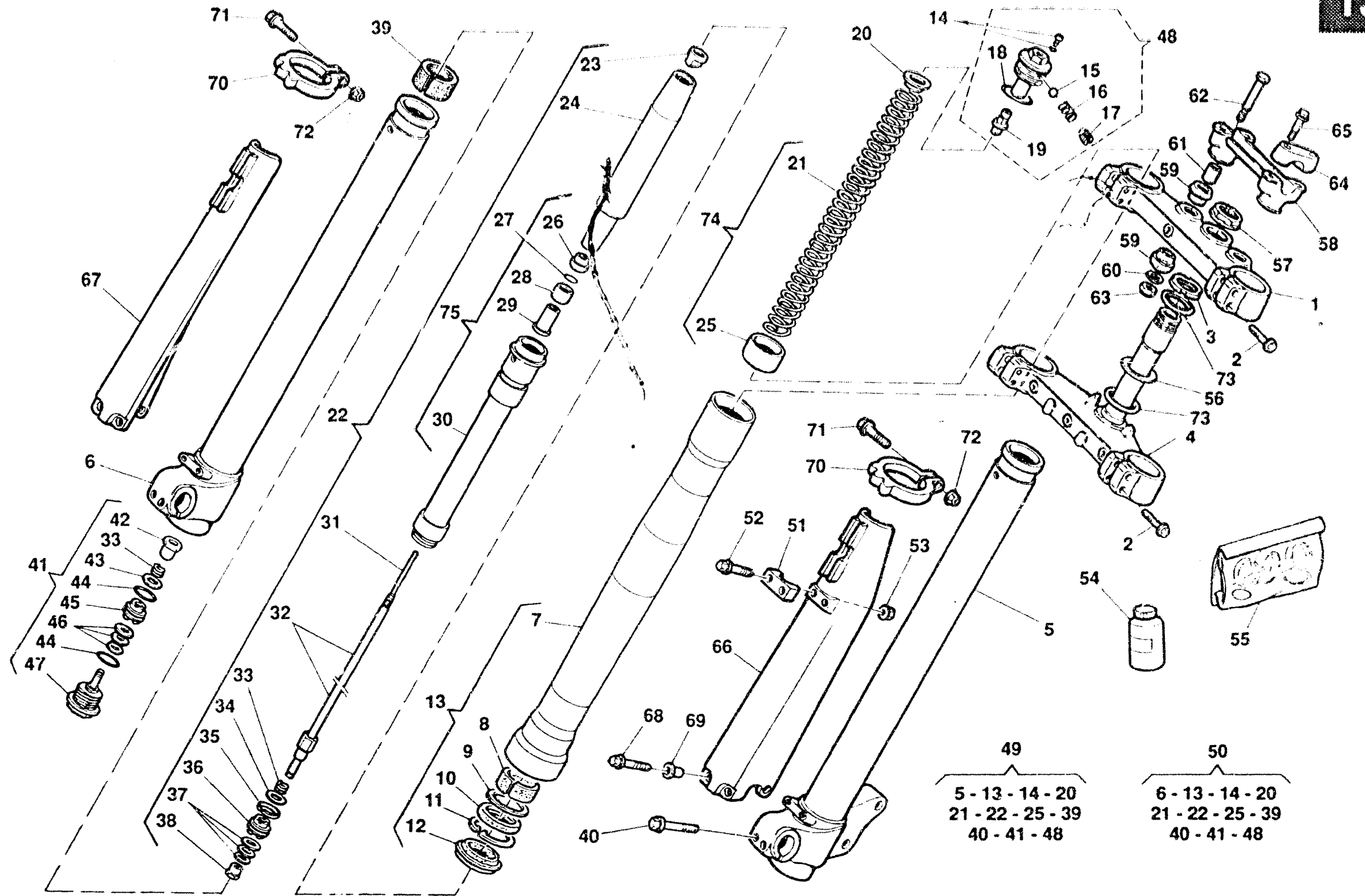



TE - TE U.S.A.
410 - 610 / 99
TC 610 / 99

TAVOLA
DRAWING
TABLE
BILD
TABLA

13

SOSPENSIONE ANTERIORE Ø 45 - FRONT FORK ASSEMBLY Ø 45
SUSPENSION AVANT Ø 45 - VORDERTELESKOPGABEL Ø 45
SUSPENSION DELANTERA Ø 45

Note Notes Notas	Pos. No. Index Pos.	N. Cod. Code No. Nr. Code Cod. Nr. N. Cod.	Q.tà Qty Q.te M.ge C.ad.	DENOMINAZIONE	NAME	DESIGNATION	BESCHREIBUNG	DE NOMINACION	Verifiz. Vérif. Güting Verifiz.
WU	1	8000 69319	1	Testa di sterzo	Steering head	Tête direction	Lenkkopf	Cabezal de dirección	
C	1	8000 69319	1	Testa di sterzo	Steering head	Tête direction	Lenkkopf	Cabezal de dirección	
	2	8000 62796	8	Vite	Screw	Vis	Schraube	Tornillo	
WU	3	8000 83395	1	Ghiera registro cuscinetti	Ring nut	Embout	Nutmutter	Vírol	
C	3	8000 87717	1	Ghiera registro cuscinetti	Ring nut	Embout	Nutmutter	Vírol	
WU	4	8000 90334	1	Base di sterzo con perno	Steering crown with pin	Socle de direction avec pivot	Gabelbrücke mit Bolzen	Base de dirección con perno	
C	4	8000 89930	1	Base di sterzo con perno	Steering crown with pin	Socle de direction avec pivot	Gabelbrücke mit Bolzen	Base de dirección con perno	
	5	8000 91507	1	Stelo Sx. compl.	L.H. slider assy	Montant G. compl.	Bein, Kpl. L.	Deslizable izrda. compl.	
	6	8000 91506	1	Stelo Dx. compl.	R.H. slider assy	Montant D. compl.	Bein, Kpl. R.	Deslizable der. compl.	
	7	8000 91473	2	Portastelo	Pipe	Tuyau	Rohr	Tubo	
	8	8000 70328	2	Bussola	Bushing	Douille	Buchse	Manguito	
	9	8000 86385	2	Scodellino	Cup	Cuvette	Teller	Cubeta	
	10	8000 85930	2	Anello di tenuta	Seal ring	Bague de retenue	Dichtring	Anillo de retención	
	11	8000 81161	2	Anello di fermo	Stop ring	Bague d'arrêt	Haltering	Anillo de retención	
	12	8000 81162	2	Raschiapolvere	Dust scraper	Racloir poudre	Pulverabschaber	Rascador de polvo	
	13	8000 91474	2	Portastelo completo	Pipe assy	Groupe tuyau compl.	Rohrgruppe Kpl	Grupo tubo compl.	
	14	8000 84702	2	Vite	Screw	Vis	Schraube	Tornillo	
	15	8000 91475	2	Sfera	Ball	Bille	Kugel	Esfera	
	16	8000 91476	2	Molla per sfera	Spring	Ressort	Feder	Resorte	
	17	8000 91477	2	Grano filettato	Dowel	Grain	Stift	Pasadór	
	18	8000 91478	2	Anello OR	O-Ring	Bague OR	O-Ring	Anillo OR	
	19	8000 91479	2	Gruppo registro	Adjuster set	Groupe réglage	Regiergruppe	Grupo regulación	
	20	8000 77373	2	Scodellino	Cup	Cuvette	Teller	Cubeta	
WU	21	8000 91481	2	Molla k= 4,2 N/mm	Spring k= 4,2 N/mm	Ressort k= 4,2 N/mm	Feder k= 4,2 N/mm	Resorte k= 4,2 N/mm	
C	21	8000 91508	2	Molla k= 4,5 N/mm	Spring k= 4,5 N/mm	Ressort k= 4,5 N/mm	Feder k= 4,5 N/mm	Resorte k= 4,5 N/mm	
	22	8000 91505	2	Gruppo pompante compl.	Damping element compl.	Amortissement compl.	Schwingungsdämpfer Kpl.	Bombeadora compl.	
	23	8000 89238	2	Dado	Nut	Ecrou	Mutter	Tuerca	
	24	8000 91482	2	Guidamolla	Spring guide	Guide ressort	Federführung	Guía resorte	
	25	8000 91483	2	Tubetto	Pipe	Tuyau	Rohr	Tubo	
	26	8000 91484	2	Dado	Nut	Ecrou	Mutter	Tuerca	
	27	8000 91485	2	Anello SEEGER	SEEGER ring	Anneau SEEGER	SEEGER Ring	Anillo SEEGER	
	28	8000 91486	2	Tampone di fondo	Pad	Tampon	Stopfen	Tampón	

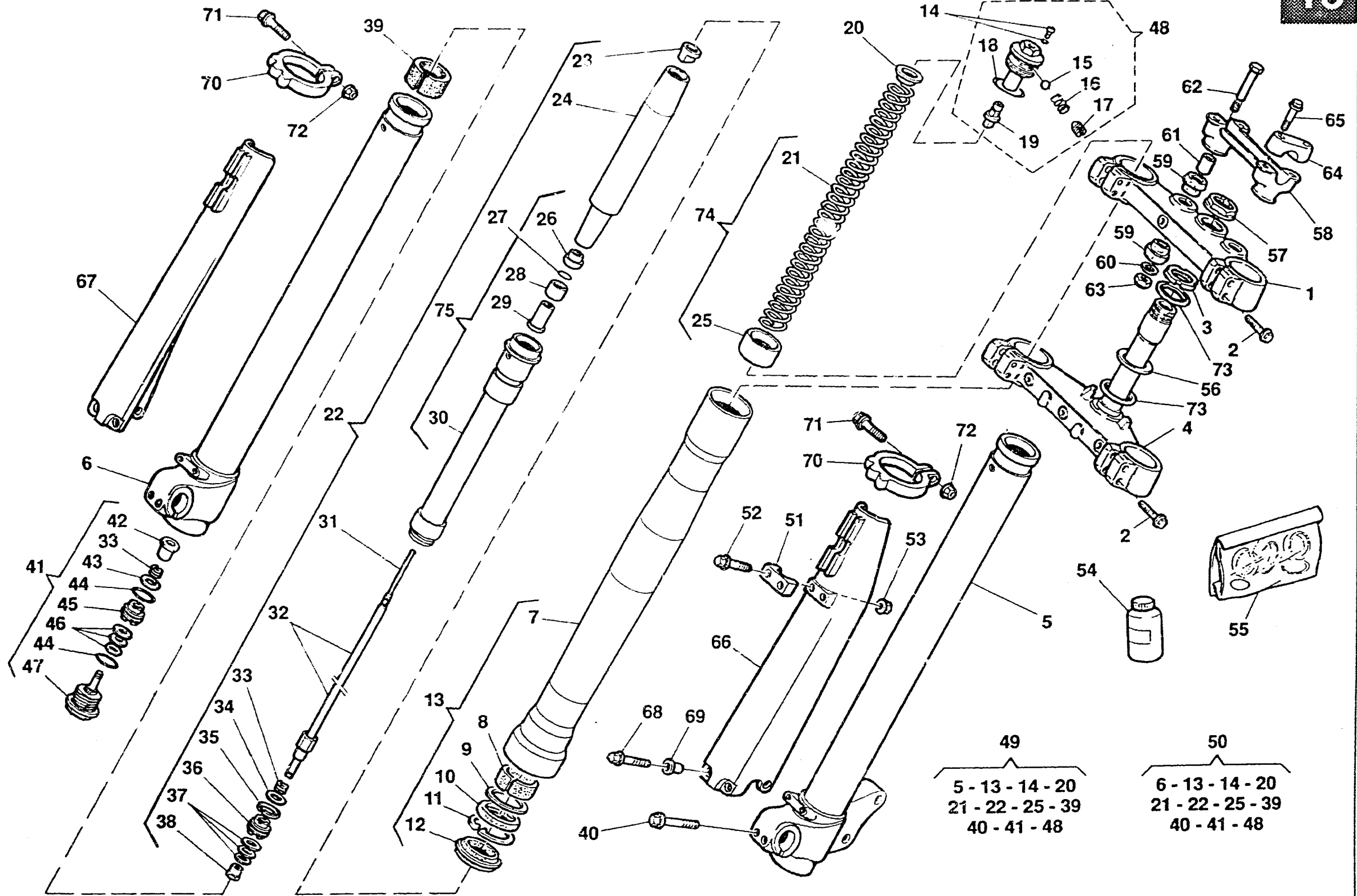



TE - TE U.S.A.
410 - 610 / 99
TC 610 / 99

TAVOLA
DRAWING
TABLE
BILD
TABLA

13

SOSPENSIONE ANTERIORE Ø 45 - FRONT FORK ASSEMBLY Ø 45
SUSPENSION AVANT Ø 45 - VORDERTELESKOPGABEL Ø 45
SUSPENSION DELANTERA Ø 45

Note Notes Notas	Pos. No. Index Pos.	N. Cod. Code No. Nr. Code Code Nr N. Cod.	Q.tà Q.ty Q.té M.ge C.ad	DENOMINAZIONE	NAME	DESIGNATION	BESHREIBUNG	DENOMINACION	Validità Validity Validité Gültig Validez
	29	8000 91487	2	Distanziale	Spacer	Entretoise	Distanzstück	Separador	
	30	8000 91488	2	Custodia	Housung	Cage	Korb	Custodia	
	31	8000 91490	2	Asta interna	Internal rod	Barre	Stange	Varilla	
	32	8000 91489	2	Ass. asta	Rod assy	Barre compl.	Stange Kpl	Grupo varilla	
	33	8000 89241	4	Molla	Spring	Ressort	Feder	Resorte	
	34	8000 89245	2	Lamella	Plate	Lamelle	Plättchen	Laminilla	
	34	8000 91491	2	Lamella	Plate	Lamelle	Plättchen	Laminilla	
	34	8000 91492	2	Lamella	Plate	Lamelle	Plättchen	Laminilla	
	34	8000 81181	2	Lamella	Plate	Lamelle	Plättchen	Laminilla	
	35	8000 89243	2	Segmento	Circlip	Segment	Colbenring	Segmento	
	36	8000 91493	2	Pistone estensione	R.H. piston	Piston D.	Kolbe R.	Pistón der.	
	37	8000 91494	4	Lamella	Plate	Lamelle	Plättchen	Laminilla	
	37	8000 91495	2	Lamella	Plate	Lamelle	Plättchen	Laminilla	
	37	8000 91496	2	Lamella	Plate	Lamelle	Plättchen	Laminilla	
	38	8000 74310	2	Dado	Nut	Ecrou	Mutter	Tueca	
	39	8000 91497	2	Bussola	Bushing	Douille	Buchse	Manguito	
	40	8000 62729	4	Vite	Screw	Vis	Schraube	Tomillo	
WU	41	8000 91504	2	Ass. valvola di fondo	Valve	Soupape	Ventil	Válvula	
C	41	8000 91510	2	Ass. valvola di fondo	Valve	Soupape	Ventil	Válvula	
R	41	8000 91718	2	Ass. valvola di fondo	Valve	Soupape	Ventil	Valvula	
	42	8000 89252	2	Dado	Nut	Ecrou	Mutter	Tuerca	
	43	8000 89242	2	Lamella	Plate	Lamelle	Plättchen	Laminilla	
	44	8000 40409	4	Anello OR	O-Ring	Bague OR	O-Ring	Anillo OR	
WU	45	8000 91499	2	Pistone compressione	Piston	Piston	Kolbe	Pistón	
C	45	8000 91509	2	Pistone compressione	Piston	Piston	Kolbe	Pistón	
WU	46	8000 91500	2	Lamella	Plate	Lamelle	Plättchen	Laminilla	
WU	46	8000 91501	4	Lamella	Plate	Lamelle	Plättchen	Laminilla	
WU	46	8000 91495	2	Lamella	Plate	Lamelle	Plättchen	Laminilla	
WU	46	8000 91496	2	Lamella	Plate	Lamelle	Plättchen	Laminilla	
WU	46	8000 91502	4	Lamella	Plate	Lamelle	Plättchen	Laminilla	
C	46	8000 91500	6	Lamella	Plate	Lamelle	Plättchen	Laminilla	
C	46	8000 91501	4	Lamella	Plate	Lamelle	Plättchen	Laminilla	

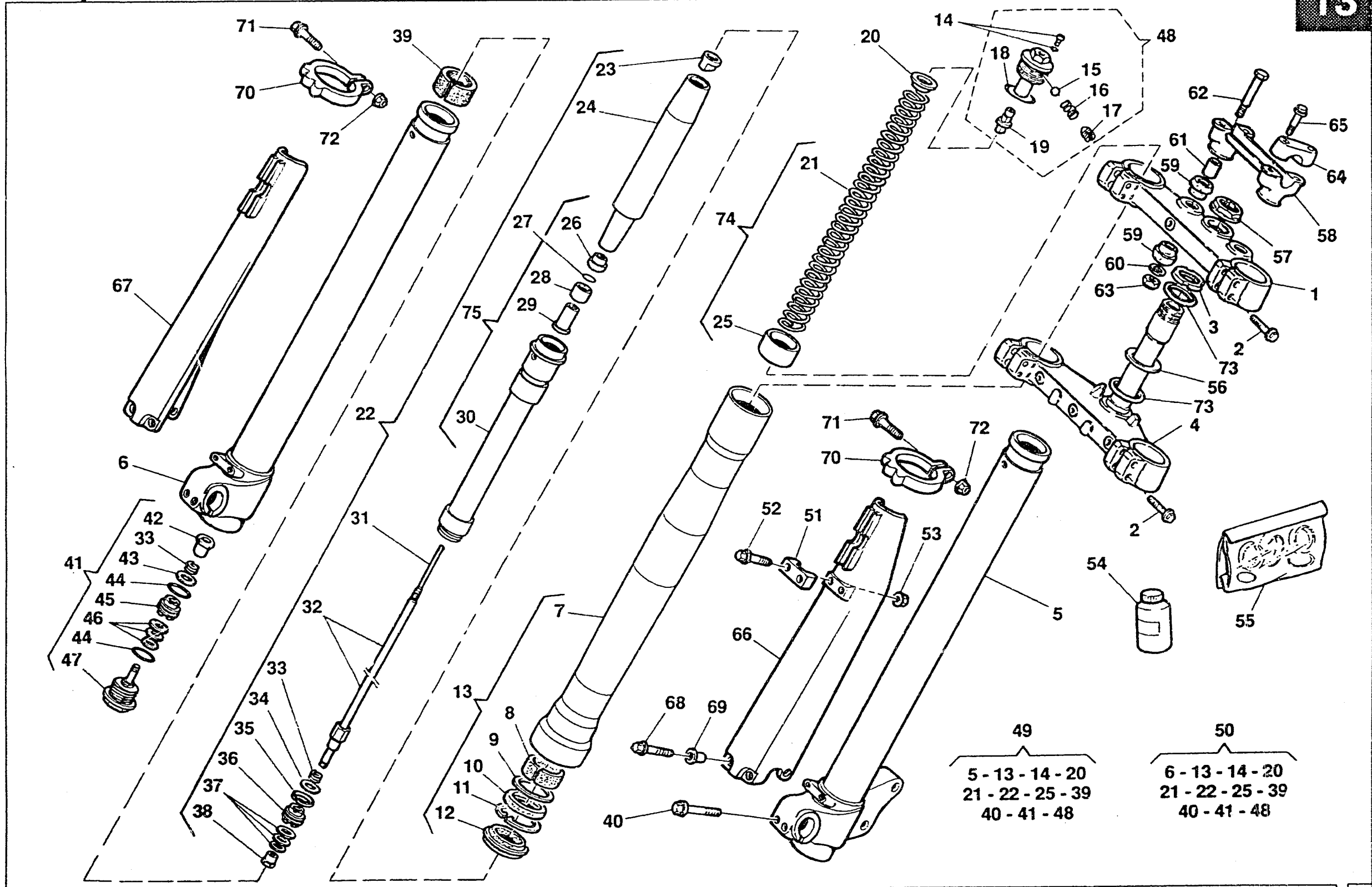



TE - TE U.S.A.
410 - 610 / 99
TC 610 / 99

TAVOLA
DRAWING
TABLE
BILD
TABLA

13

SOSPENSIONE ANTERIORE Ø 45 - FRONT FORK ASSEMBLY Ø 45
SUSPENSION AVANT Ø 45 - VORDERTELESKOPGABEL Ø 45
SUSPENSION DELANTERA Ø 45

Nota Notes Marka Notas	Pos. No. N. Index Pos.	N. Cod. Code No. Nr. Code Cods Nr N. Cod.	Q.tà Q.ty Q.té M.ge C.ad	DENOMINAZIONE	NAME	DESIGNATION	BESHREIBUNG	DENOMINACION	Validità Validity Validez Gültig Validez
C	46	8000 91495	2	Lamella	Plate	Lamelle	Plättchen	Laminilla	
C	46	8000 91496	2	Lamella	Plate	Lamelle	Plättchen	Laminilla	
	47	8000 91503	2	Valvola	Valve	Soupape	Ventil	Valvula	
	48	8000 91480	2	Gruppo tappo	Plug assy	Groupe bouchon	Verschlussgruppe Kpl	Grupo tapón	
WU	49	8000 91157	1	Gamba Sx. compl.	L.H. fork leg assy	Fourche compl. G.	Telegabel, Kpl. L.	Horquill izrda. compl.	
C	49	8000 91161	1	Gamba Sx. compl.	L.H. fork leg assy	Fourche compl. G.	Telegabel, Kpl. L.	Horquill izrda. compl.	
WU	50	8000 91156	1	Gamba Dx. compl.	R.H. fork leg assy	Fourche complete D.	Telegabel Kpl. R.	Horquilla derech. compl.	
C	50	8000 91160	1	Gamba Dx. compl.	R.H. fork leg assy	Fourche complete D.	Telegabel Kpl. R.	Horquilla derech. compl.	
	51	80C0 69981	1	Piastrina	Plate	Plaquette	Plättchen	Placa	
	52	8A00 67997	2	Vite	Screw	Vis	Schraube	Tomillo	
	53	8000 61355	2	Dado	Nut	Ecrou	Mutter	Tuerca	
	54	8000 80260	1	Olio forcella	Front fork oil	Huile fourche avant	Öl für die Vordergabel	Aceite horquilladelantera	
	55	8000 91519	1	Gruppo guarnizioni	Gasket set	Groupe garnitures	Dichtungssatz	Grupo juntas	
WU	56	8A00 65503	2	Rosetta piana	Washer	Rondelle	Scheibe	Arandela	
C	56	8000 87736	1	Rosetta piana	Washer	Rondelle	Scheibe	Arandela	
WU	57	8000 69315	1	Dado	Nut	Ecrou	Mutter	Tuerca	
C	57	8A00 69315	1	Dado	Nut	Ecrou	Mutter	Tuerca	
	58	8000 73141	1	Mozzetto inferiore	Hub	Moyeau	Radnabe	Cbo	
	59	8000 60233	4	Gommino	Rubber pad	Pièce caoutchouc	Gummistück	Junta de goma	
	60	8000 60234	2	Rosetta piana	Washer	Rondelle	Scheibe	Arandela	
	61	8000 53155	2	Distanziale	Spacer	Entretoise	Distanzstück	Separador	
	62	60N1 01219	2	Vite	Screw	Vis	Schraube	Tomillo	
	63	8000 61314	2	Dado	Nut	Ecrou	Mutter	Tuerca	
	64	8000 68516	2	Mozzetto superiore	Hub	Moyeau	Radnabe	Cubo	
	65	8000 62733	4	Vite	Screw	Vis	Schraube	Tomillo	
	66	80C0 69337	1	Protezione steli Sx.	Guard L.H.	Protection D.	Schutz L.	Protección izq.	
	67	80C0 69338	1	Protezione steli Dx.	Guard R.H.	Protection G.	Schutz R.	Protección der.	
	68	8000 67997	6	Vite	Screw	Vis	Schraube	Tomillo	
	69	8000 69282	6	Bussola	Bush	Douille	Buchse	Manguito	
	70	80A0 70558	2	Anello	Ring	Bague	Ring	Anilo	
	71	8B00 66525	2	Vite	Screw	Vis	Schraube	Tomillo	
	72	8000 56443	2	Dado	Nut	Ecrou	Mutter	Tuerca	

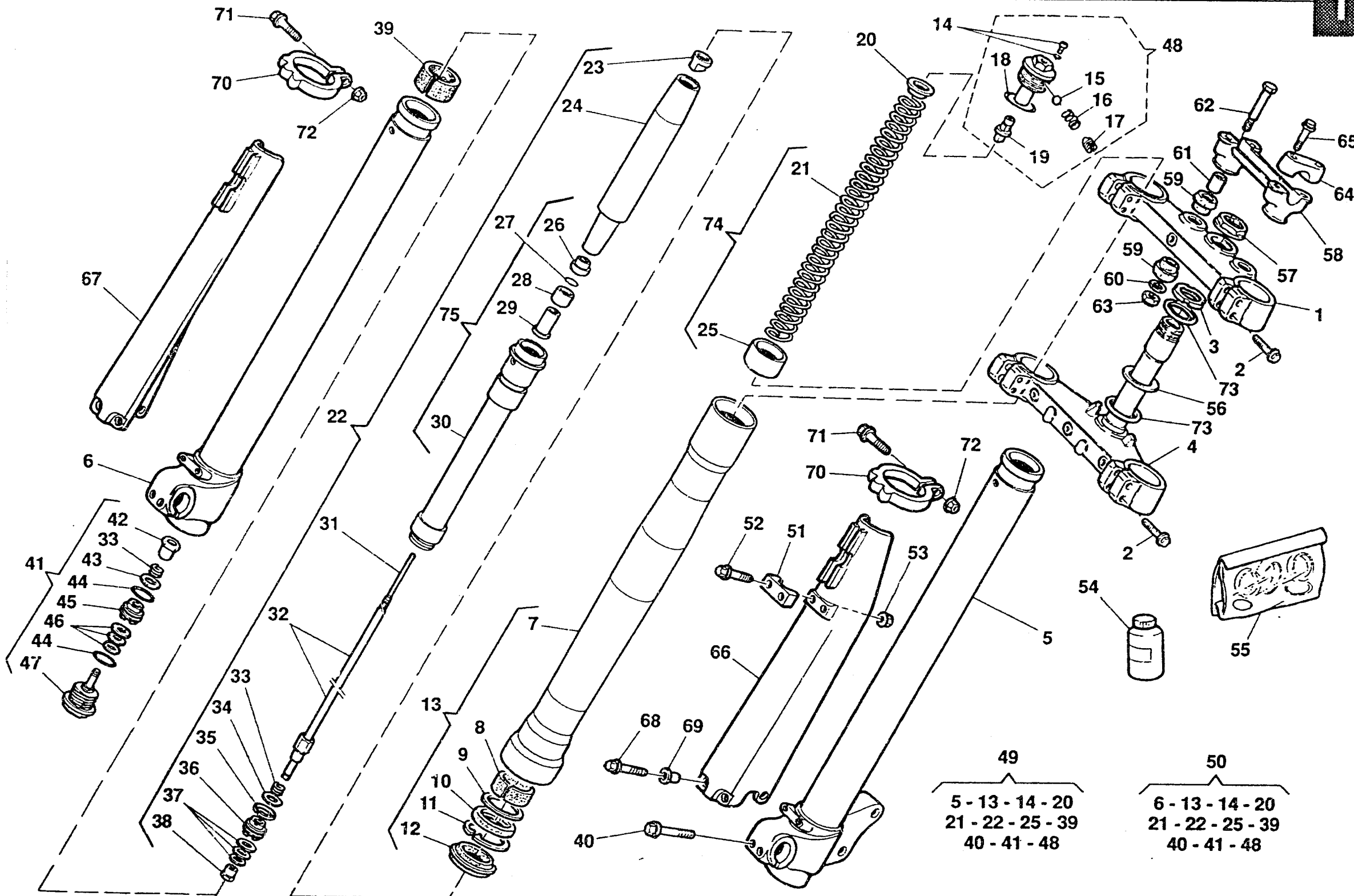



TE - TE U.S.A.
410 - 610 / 99
TC 610 / 99

TAVOLA
DRAWING
TABLE
BILD
TABLA

13

SOSPENSIONE ANTERIORE Ø 45 - FRONT FORK ASSEMBLY Ø 45
SUSPENSION AVANT Ø 45 - VORDETELESKOPGABEL Ø 45
SUSPENSION DELANTERA Ø 45

Note Notes Marka Notas	Pos. No. Index Pos.	N. Cod. Code No. Nr. Code Code Nr N. Cod.	Q.tà Q.ty Q.té M.ge C.ad	DENOMINAZIONE	NAME	DESIGNATION	BESHREIBUNG	DENOMINACION	Valida Valdya Valdny Gulig Valdez
C	73	8000 87745	2	Guarnizione di tenuta	Gasket	Garniture	Dichtung	Guarnición	
Swu	74	8000 91608	1	Kit molla k=4,0 N/mm	Spring k=4,0 N/mm	Ressort k=4,0 N/mm	Feder k=4,0 N/mm	Resorte k=4,0 N/mm	
Sc	74	8000 91609	1	Kit molla k=4,2 N/mm	Spring k=4,2 N/mm	Ressort k=4,2 N/mm	Feder k=4,2 N/mm	Resorte k=4,2 N/mm	
R	74	8000 91607	1	Kit molla k=3,8 N/mm	Spring k=3,8 N/mm	Ressort k=3,8 N/mm	Feder k=3,8 N/mm	Resorte k=3,8 N/mm	
R	74	8000 91608	1	Kit molla k=4,0 N/mm	Spring k=4,0 N/mm	Ressort k=4,0 N/mm	Feder k=4,0 N/mm	Resorte k=4,0 N/mm	
R	74	8000 91609	1	Kit molla k=4,2 N/mm	Spring k=4,2 N/mm	Ressort k=4,2 N/mm	Feder k=4,2 N/mm	Resorte k=4,2 N/mm	
R	74	8000 91610	1	Kit molla k=4,5 N/mm	Spring k=4,5 N/mm	Ressort k=4,5 N/mm	Feder k=4,5 N/mm	Resorte k=4,5 N/mm	
R	74	8000 91611	1	Kit molla k=4,8 N/mm	Spring k=4,8 N/mm	Ressort k=4,8 N/mm	Feder k=4,8 N/mm	Resorte k=4,8 N/mm	
R	75	8000 91717	1	Kit corsa forcella	Fork travel kit	Groupe debaitement fourche	Gabels Ausschlag Gruppe Kpl.	Grupo distancia horquilla	

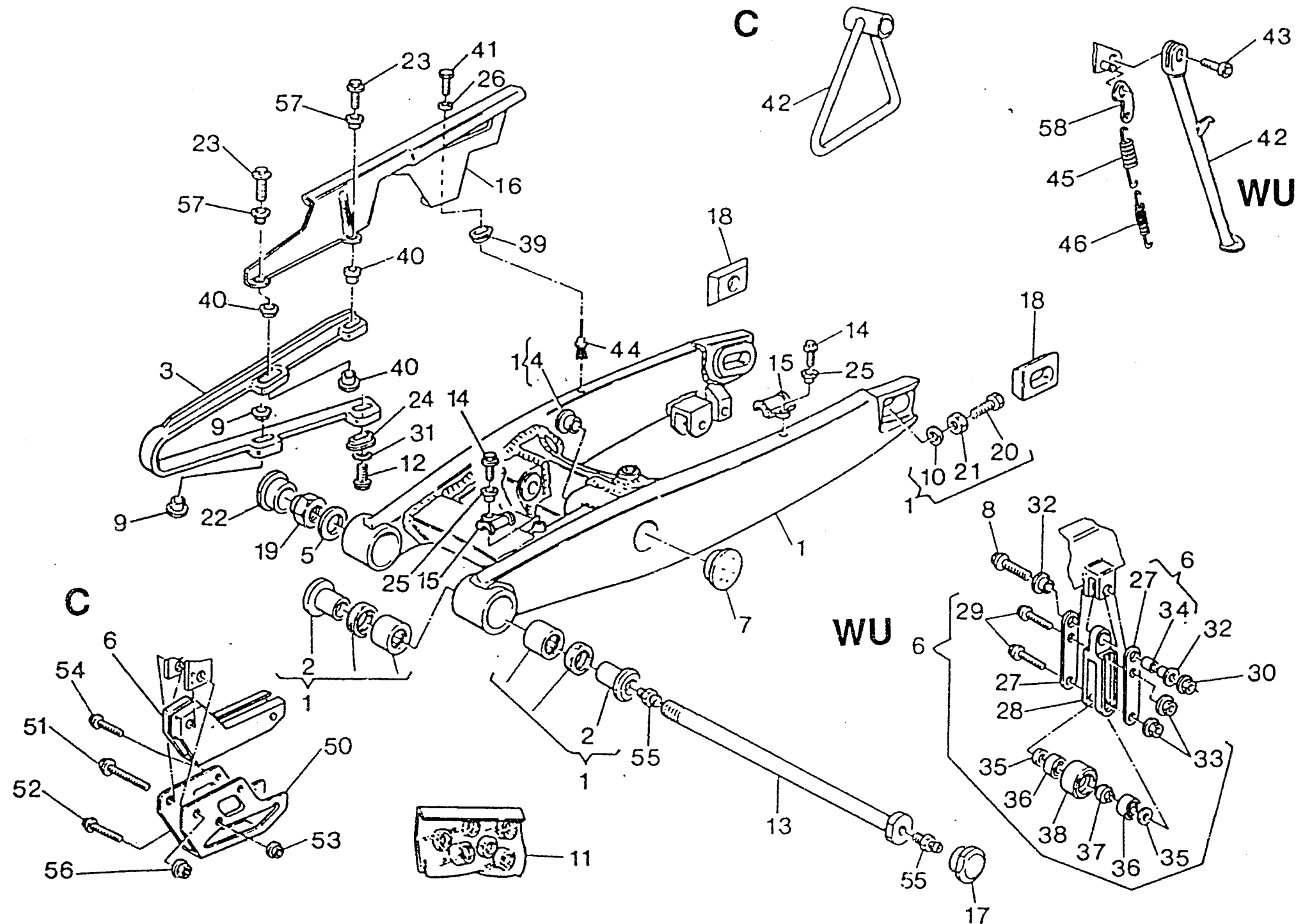



TE - TE U.S.A.
410 - 610 / 99
TC 610 / 99

TAVOLA
DRAWING
TABLE
BILD
TABLA

14

FORCELLONE - SWING ARM
FOURCHE - GABEL
HORQUILLA

Note Notes Notas	Pos. No. Index Pos.	N. Cod. Code No. Nr. Code Code Nr N. Cod.	Q.tà Q.ty Q.te M.ge C.ad	DENOMINAZIONE	NAME	DESIGNATION	BESHREIBUNG	DENOMINACION	Validità Validity Validité Gültig Validez
	1	8000 76263	1	Forcellone completo	Compl. fork	Fourche complete	Gabel, Kpl.	Horquilla compl.	
	2	8000 66196	4	Bussola	Bushing	Douille	Buchse	Manguito	
	3	8000 72884	1	Pattino catena	Chain slider	Glissière	Gleitbahn	Plato catena	
	4	8B00 42029	4	Bussola	Bushing	Douille	Buchse	Manguito	
	5	62N1 15524	1	Rosetta piana	Washer	Rondelle	Scheibe	Arandela	
WU	6	8000 72873	1	Guidacatena	Chain guide	Guide-chaine	Kettenführung	Guía-cadena	
C	6	8000 72868	1	Guidacatena	Chain guide	Guide-chaine	Kettenführung	Guía-cadena	
	7	80A0 74388	3	Tappo	Plug	Bouchon	Verschluss	Tapón	
XY	8	8000 62795	1	Vite	Screw	Vis	Schraube	Tornillo	
	9	8000 75166	2	Scodellino	Cup	Cuvette	Teller	Cubeta	
	10	8000 08536	2	Rosetta	Washer	Rondelle	Scheibe	Arandela	
	11	8000 67373	1	Kit cuscinetti e anelli di tenuta	Bearing and seal ring kit	Gr. roulemen.et bague de reten.	Kugellager und Dichtring gruppe	Kit cojinete y anillo de retención	
WU	12	8000 67997	2	Vite	Screw	Vis	Schraube	Tornillo	
C	12	8000 67997	4	Vite	Screw	Vis	Schraube	Tornillo	
	13	8000 64591	1	Perno forcellone	Fork pin	Pivot fourche	Gabelbolzen	Perno horquilla	
	14	8000 20536	2	Vite	Screw	Vis	Schraube	Tornillo	
	15	80A0 73456	2	Guidacavo	Cable guide	Guide câble	Kabelführung	Guía-cable	
XY	16	80A0 73426	1	Copricatena	Chain guard	Carter de chaine	Kettenkasten	Cubre-cadena	
	17	80A0 66202	1	Tappo	Plug	Bouchon	Verschluss	Tapón	
	18	8000 71624	1	Tendicatena lato dado	Chain adjuster - nut side	Tendeur de chaine côtés ecrou	Kettenspanner Mutterseite	Tensor de cadena lato tuerca	
	18	8000 71625	1	Tendicatena lato perno	Chain adjuster - pin side	Tendeur de chaine côtés pivot	Kettenspanner bolzenseite	Tensor de cadena lato perno	
	19	1511 24901	1	Dado	Nut	Ecrou	Mutter	Tuerca	
	20	8C00 61121	2	Vite	Screw	Vis	Schraube	Tornillo	
	21	8000 17810	2	Dado	Nut	Ecrou	Mutter	Tuerca	
XY	23	8C00 67997	2	Vite	Screw	Vis	Schraube	Tornillo	
	24	8000 59289	3	Scodellino	Cup	Cuvette	Teller	Cubeta	
	25	8000 69282	2	Bussola	Bushing	Douille	Buchse	Manguito	
XY	26	8000 36137	1	Rosetta	Washer	Rondelle	Scheibe	Arandela	
Y	27	8000 72875	2	Lamiera guidacatena	Chain guide	Guide-chaine	Kettenführung	Guía-cadena	
Y	28	8000 72874	1	Piastra d'attacco	Plate	Plaque	Platte	Placa	
Y	29	8000 62731	2	Vite	Screw	Vis	Schraube	Tornillo	
Y	30	8000 43928	1	Dado	Nut	Ecrou	Mutter	Tuerca	

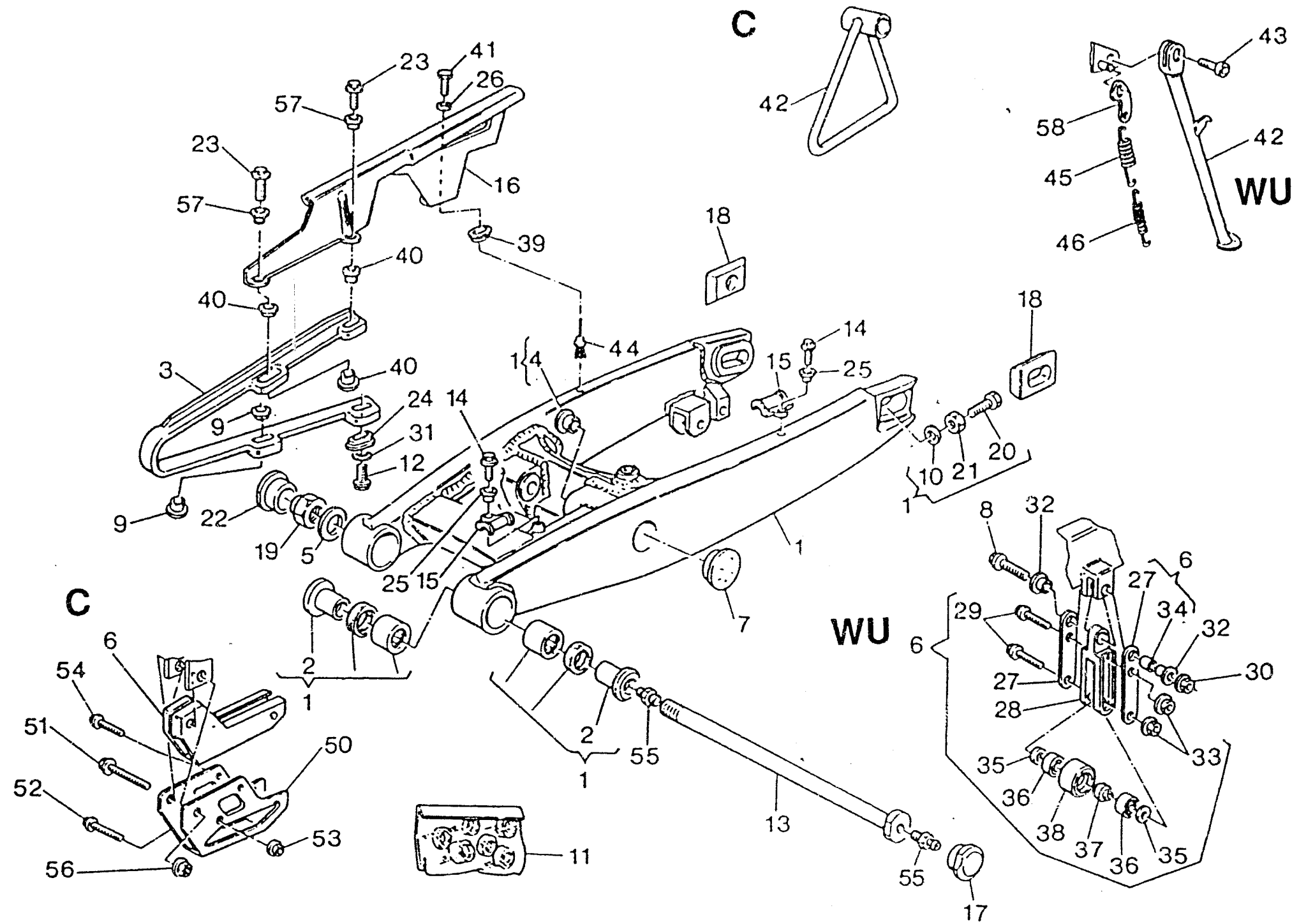



TE - TE U.S.A.
410 - 610 / 99
TC 610 / 99

TAVOLA
DRAWING
TABLE
BILD
TABLA

14

FORCELLONE - SWING ARM
FOURCHE - GABEL
HORQUILLA

Note Notes Marka Notas	Pos. No. N. Index Pos.	N. Cod. Code No. Nr. Code Code Nr N. Cod.	Q.tà Q.ty Q.té M.ge C.ad	DENOMINAZIONE	NAME	DESIGNATION	BESHREIBUNG	DENOMINACION	Validità Validity Validez Gültig Validez
	31	8000 36137	2	Rosetta	Washer	Rondelle	Scheibe	Arandela	
Y	32	8A00 66661	1	Bussola	Bushing	Douille	Buchse	Manguito	
Y	33	8000 44240	2	Dado	Nut	Ecrou	Mutter	Tuerca	
Y	34	1515 50601	1	Bussola elastica	Bushing	Douille	Buchse	Manguito	
Y	35	8000 45495	2	Rosetta di spallamento	Washer	Rondelle	Scheibe	Arandela	
Y	36	8000 63312	2	Cuscinetto	Bearing	Roulement	Kugellager	Cojinete	
Y	37	8000 65412	1	Distanziale	Spacer	Entretoise	Distanzstück	Separador	
Y	38	8000 65411	1	Rullo guidacatena	Roller	Aiguille	Rolle	Rodillo	
XY	39	8000 59289	1	Scodellino	Cup	Cuvette	Teller	Cubeta	
XY	40	8000 75166	3	Scodellino	Cup	Cuvette	Teller	Cubeta	
XY	41	8000 20538	1	Vite	Screw	Vis	Schraube	Tomillo	
WU	42	8AA0 73877	1	Gamba laterale	Side stand	Bequille lat.	Seitenständer	Horquilla lateral	
C	42	8000 74016	1	Gamba laterale	Side stand	Bequille lat.	Seitenständer	Horquilla lateral	
WY	43	8000 84177	1	Vite	Screw	Vis	Schraube	Tomillo	
UY	43	8000 75957	1	Vite	Screw	Vis	Schraube	Tomillo	
CU	44	8000 75160	1	Rivetto	Rivet	Rivet	Niet	Remache	
WU	45	8000 62675	1	Molla esterna	Spring	Ressort	Feder	Resorte	
WU	46	8000 62676	1	Molla interna	Spring	Ressort	Feder	Resorte	
C	50	8000 72869	1	Staffa	Bracket	Etrier	Buegel	Brida	
C	51	8A00 69056	1	Vite	Screw	Vis	Schraube	Tomillo	
C	52	8000 62731	1	Vite	Screw	Vis	Schraube	Tomillo	
C	53	8000 44240	1	Dado	Nut	Ecrou	Mutter	Tuerca	
C	54	8000 62725	1	Vite	Screw	Vis	Schraube	Tomillo	
	55	8000 01412	2	Ingrassatore	Lubricator	Graisseur	Schmierbüchse	Lubricador	
C	56	8000 43928	1	Dado	Nut	Ecrou	Mutter	Tuerca	
XY	57	8A00 69282	2	Distanziale	Spacer	Entretoise	Distanzstück	Separador	
WU	58	8000 84176	1	Piastrina	Plate	Plaquette	Plättchen	Placa	

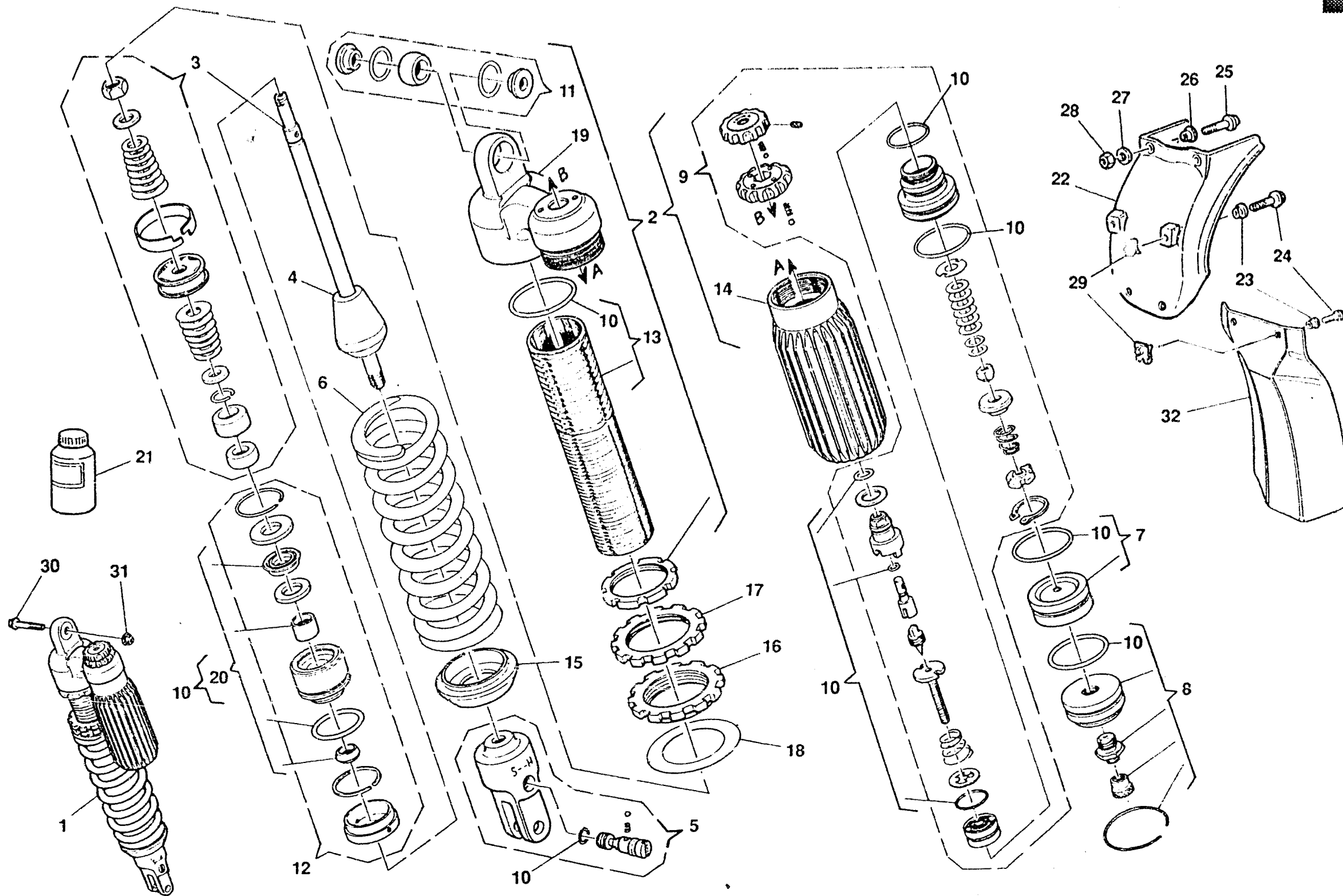



TE - TE U.S.A.
410 - 610 / 99
TC 610 / 99

TAVOLA
DRAWING
TABLE
BILD
TABLA

15

AMMORTIZZATORE POSTERIORE - REAR SUSPENSION
SUSPENSION ARRIÈRE - HINTERHAUFHANGUNG
SUSPENSION TRASERA

Note Notes Notas	Pos. No. Index Pos.	N. Cod. Code No. Nr. Code Code Nr N. Cod.	Q.1a Q.1y Q.1e M.ge C.ad	DENOMINAZIONE	NAME	DESIGNATION	BESHREIBUNG	DENOMINACION	Valdha Valdhy Valdhé Gültig Valdez
WU	1	8000 90071	1	Ammortizzatore completo	Shock-absorber	Ammortisseur	Stossdämpfer	Amortigüador	
C	1	8000 90810	1	Ammortizzatore completo	Shock-absorber	Ammortisseur	Stossdämpfer	Amortigüador	
	2	8000 91236	1	Gruppo corpo	Damper case assy	Groupe corps amortisseur	Stossdämpferkörper Kpl.	Corpo amortigüador compl.	
WU	3	8000 91237	1	Gruppo stelo	Rod assy	Groupe tige	Pumpenstückgruppe	Grupo espiga	
C	3	8000 91245	1	Gruppo stelo	Rod assy	Groupe tige	Pumpenstückgruppe	Grupo espiga	
	4	8000 89083	1	Tampone	Pad	Tampon	Stopfen	Tampón	
	5	8000 91239	1	Gruppo forcella	Fork assy	Groupe fourche	Gabelgruppe Kpl.	Grupo horquilla	
WU	6	8000 87907	1	Molla k=5,8 Kg/mm	Spring	Ressort	Feder	Resorte	
C	6	8000 91246	1	Molla k=5,6+6,2 Kg/mm	Spring	Ressort	Feder	Resorte	
R	6	8000 87839	1	Molla k=5,2 Kg/mm	Spring	Ressort	Feder	Resorte	
R	6	8000 87906	1	Molla k=5,4 Kg/mm	Spring	Ressort	Feder	Resorte	
R	6	8000 88216	1	Molla k=5,6 Kg/mm	Spring	Ressort	Feder	Resorte	
R	6	8000 87907	1	Molla k=5,8 Kg/mm	Spring	Ressort	Feder	Resorte	
R	6	8000 91246	1	Molla k=5,6+6,2 Kg/mm	Spring	Ressort	Feder	Resorte	
	7	8000 89085	1	Diaframma	Diaphragm	Diaphragme	Biegeplatte	Diafragma	
	8	8000 89086	1	Gruppo serbatoio	Tank assy	Groupe reservoir	Tankgruppe Kpl.	Grupo deposito compl.	
	9	8000 89087	1	Gruppo regolazione	Adjuster set	Groupe réglage	Reglergruppe Kpl.	Grupo regulacion	
	10	8000 89088	1	Gruppo guarnizioni	Gasket set	Groupe garnitures	Dichtungssatz	Grupo juntas	
	11	8000 89089	1	Gruppo snodo	Ball joint assy	Groupe joint a rotule	Kugelgelenkgruppe Kpl.	Grupo articulacion esferica	
	12	8000 89090	1	Gruppo guida stelo	Guide rod assy	Groupe guide tige	Pumpenstückführunggruppe	Grupo guja espiga	
	13	8000 91240	1	Corpo ammortizzatore	Damper case	Corps amortisseur	Stossdämpferkörper	Corpo amortigüador	
	14	8000 91241	1	Serbatoio	Tank	Reservoir	Tank	Deposito	
	15	8000 89096	1	Fondello	Bottom	Fond	Bodenscheibe	Casquillo	
	16	8000 89097	1	Ghiera	Ring nut	Embout	Nutmutter	Virola	
	17	8000 89098	1	Ghiera	Ring nut	Embout	Nutmutter	Virola	
	18	8000 89099	1	Rosetta per molla	Washer	Rondelle	Scheibe	Arandela	
	19	8000 91242	1	Supporto serbatoio	Tank support	Support reservoir	Gastankhalterung	Soporte deposito	
	20	8000 89094	1	Gruppo guarnizioni per stelo	Rod gasket set	Jeu joints pour tige	Dichtungssatz für Pumpenstock	Serie juntas por espiga	
R	21	8000 88231	1	Olio ammortizzatore	Shock-absorber oil	Huile amortisseur	Öl für Stossdämpfer	Aceite amortigüador	
	22	8000 90108	1	Protezione ammortizzatore	Guard	Protection	Schutz	Protección	
	23	8000 69429	4	Bussola	Bushing	Douille	Buchse	Manguito	
	24	8000 62727	4	Vite	Screw	Vis	Schraube	Tornillo	

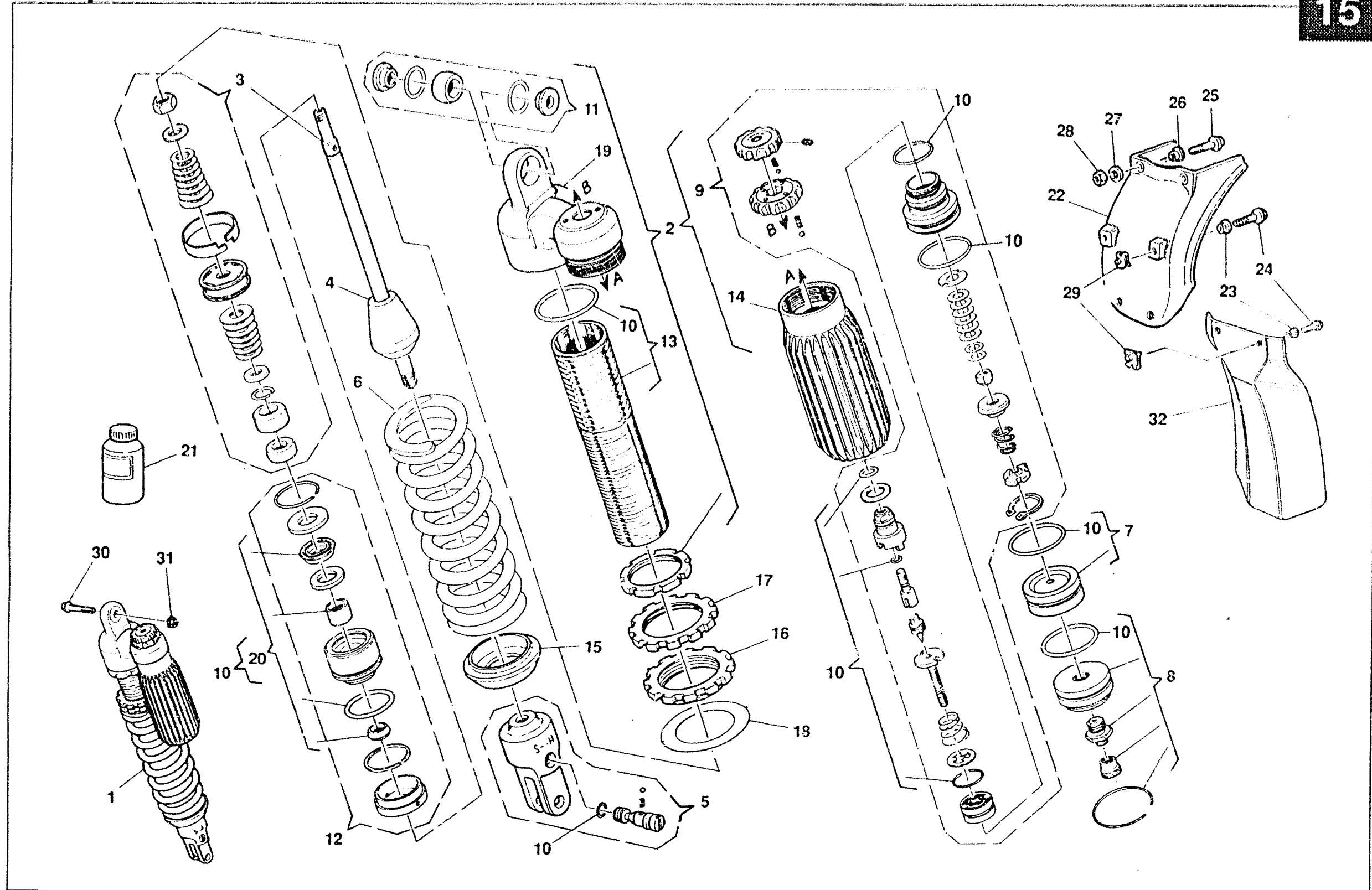



TE - TE U.S.A.
410 - 610 / 99
TC 610 / 99

TAVOLA
DRAWING
TABLE
BILD
TABLA

15

AMMORTIZZATORE POSTERIORE - REAR SUSPENSION
SUSPENSION ARRIÈRE - HINTERHAUFHANGUNG
SUSPENSION TRASERA

Note Notes Markes Notas	Pos. No. Index Pos.	N. Cod. Code No. Nr. Code Code Nr N. Cod.	Q.tà Qty Q.té M.ge C.ad	DENOMINAZIONE	NAME	DESIGNATION	BESHREIBUNG	DENOMINACION	Validità Validity Validité Gültig Validez
	25	8A00 67545	2	Vite	Screw	Vis	Schraube	Tornillo	
	26	8000 72268	2	Distanziale	Spacer	Entretoise	Distanzstück	Separador	
	27	8000 56359	2	Rosetta piana	Washer	Rondelle	Scheibe	Arandela	
	28	8000 44240	2	Dado	Nut	Ecrou	Mutter	Tuerca	
	29	8000 46893	4	Dado a graffetta	Nut	Ecrou	Mutter	Tuerca	
	30	8A00 62797	1	Vite	Screw	Vis	Schraube	Tornillo	
	31	8000 42022	1	Dado	Nut	Ecrou	Mutter	Tuerca	
	32	80A0 69551	1	Protezione ammortizzatore	Guard	Protection	Schutz	Protección	

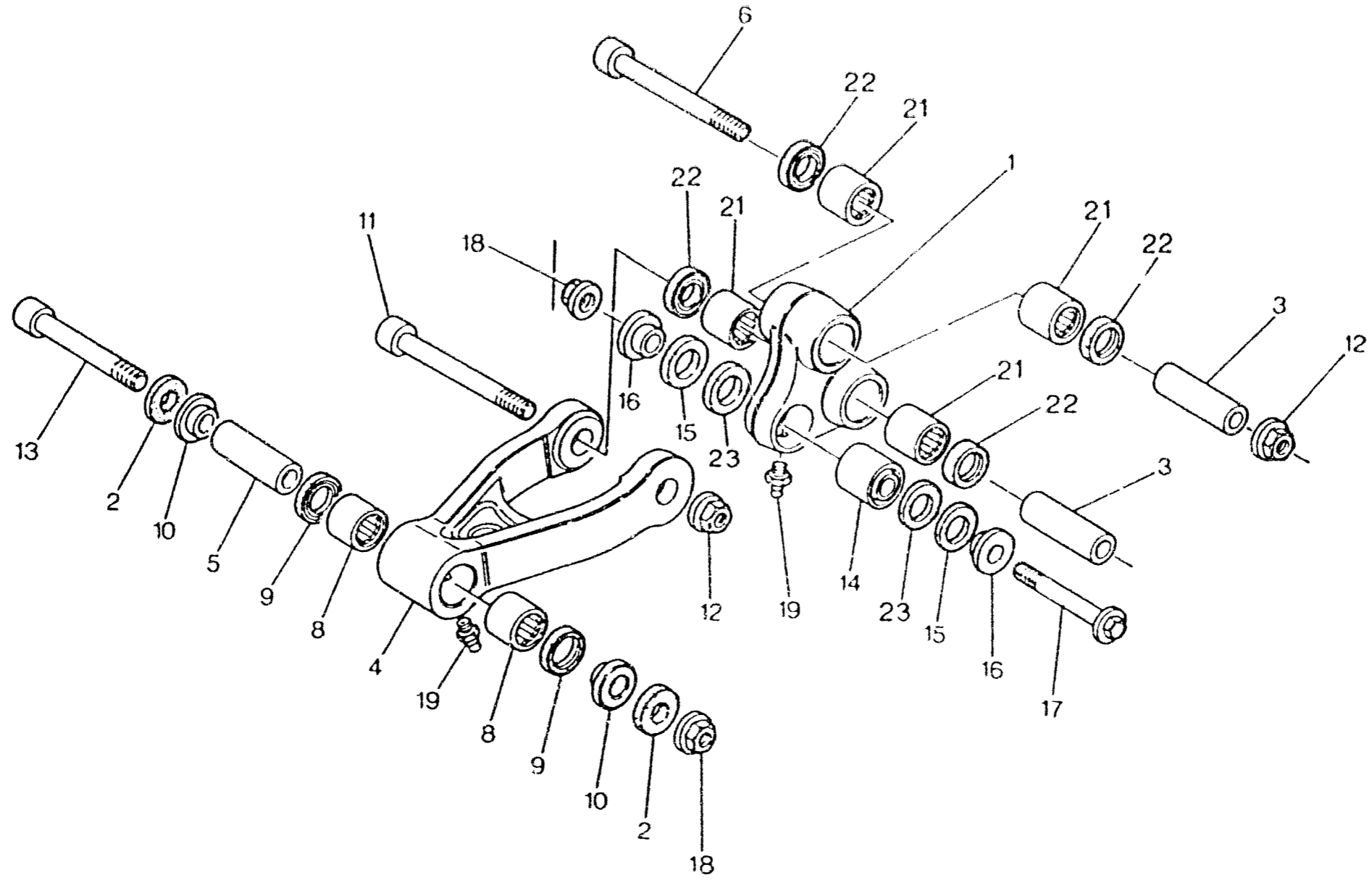



TE - TE U.S.A.
410 - 610 / 99
TC 610 / 99

TAVOLA
DRAWING
TABLE
BILD
TABLA

16

LEVERAGGI SOSPENSIONE POST. - REAR SUSPENSION LINKAGE
LEVIER SUSPENSION ARRIERE - HEBELWERK HINTERHAUFHANGUNG
PALANCA SUSPENSION TRASERA

Note Notes Marka Notas	Pos. No. Index Pos.	N. Cod. Code No. Nr. Code Code Nr. N. Cod.	Q. Ia Q. ty Q. le M. ye C. ad	DENOMINAZIONE	NAME	DESIGNATION	BESHREIBUNG	DE NOMINACION	Valida validy Valide Gültig Válidez
	1	8000 90563	1	Tirante verticale	Tie rod	Tirant	Spannstange	Tirante	
	2	8000 73394	4	Anello di feltro	Feitseal	Bague en feire	Filzring	Anillo de fieltro	
	3	8A00 75153	1	Spinotto	Gudgeon	Axe	Bolzen	Perno	
	4	8A00 69285	1	Tirante orizzontale	Tie rod	Tirant	Spannstange	Tirante	
	5	8000 59839	1	Spinotto	Gudgeon	Axe	Bolzen	Perno	
	6	8E00 74372	1	Vite	Screw	Vis	Schraube	Tomillo	
	8	8000 38956	2	Cuscinetto	Bearing	Roulement	Lager	Cojinete	
	9	8000 38957	2	Guarnizione	Gasket	Garnitue	Dichtung	Junta	
	10	8B00 42029	4	Bussola	Bushing	Douille	Buchse	Manguito	
	11	8000 77413	1	Vite	Screw	Vis	Schraube	Tomillo	
	12	8000 42023	2	Dado	Nut	Ecrou	Mutter	Tuerca	
	13	8A00 69138	1	Vite	Screw	Vis	Schraube	Tomillo	
	14	8000 72168	1	Cuscinetto	Bearing	Roulement	Lager	Cojinete	
	15	8000 38767	2	Guarnizione	Gasket	Garnitue	Dichtung	Junta	
	16	1511 33302	2	Bussola	Bushing	Douille	Buchse	Manguito	
	17	8A00 62797	1	Vite	Screw	Vis	Schraube	Tomillo	
	18	8000 42022	2	Dado	Nut	Ecrou	Mutter	Tuerca	
	19	8000 01412	2	Ingrassatore	Lubricator	Graisneur	Schmierbüchse	Lubricador	
	21	8000 42781	4	Cuscinetto	Bearing	Roulement	Lager	Cojinete	
	22	8000 32065	4	Guarnizione	Gasket	Garnitue	Dichtung	Junta	
	23	8000 90561	2	Anello di tenuta	Seal ring	Bague de retenue	Dichtring	Anillo de retención	

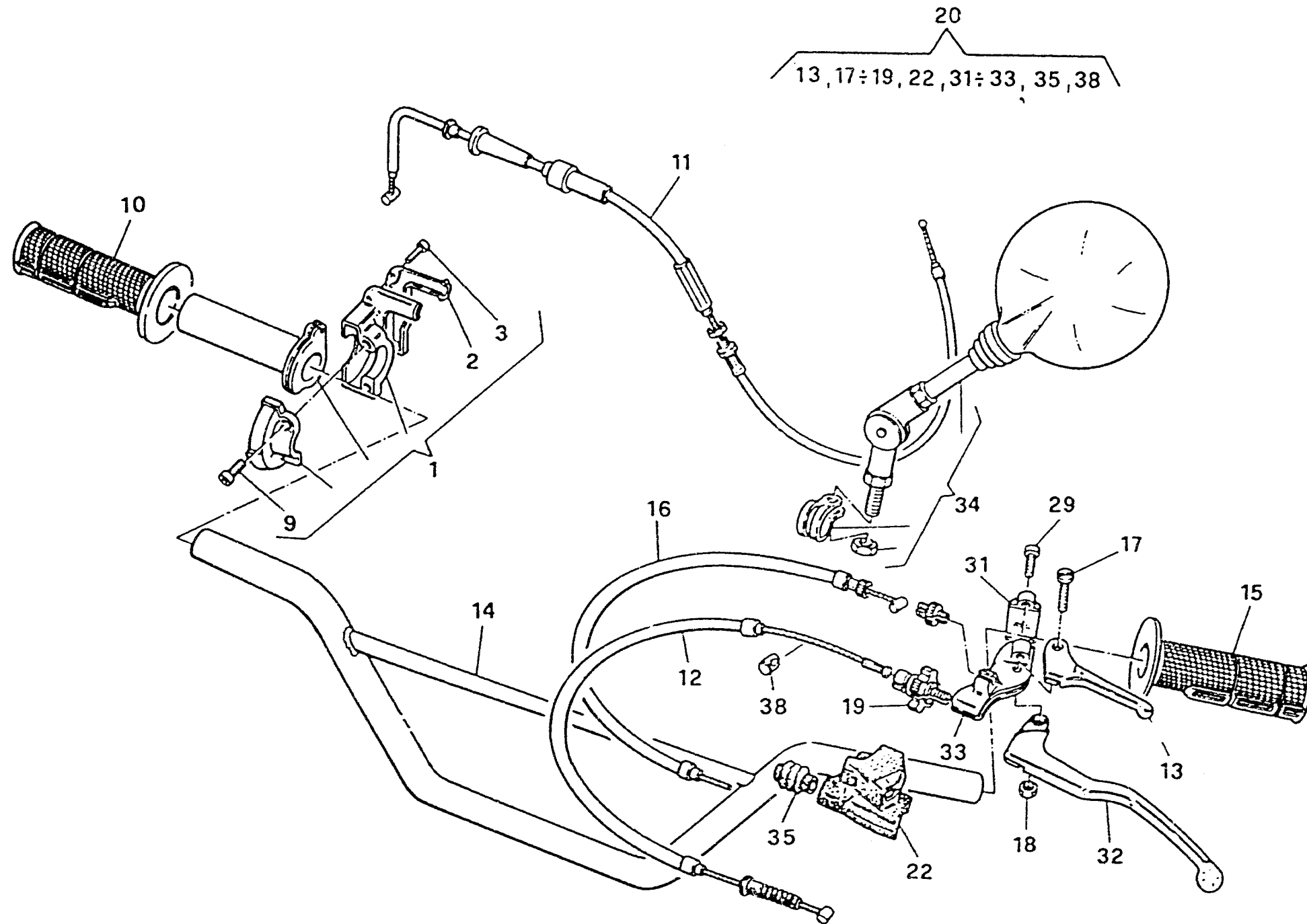



TE - TE U.S.A.
410 - 610 / 99
TC 610 / 99

TAVOLA
DRAWING
TABLE
BILD
TABLA

17

MANUBRIO E COMANDI - HANDLEBAR AND CONTROLS
GUIDON ET COMMANDES - LENKER UND STEUERORGANE
MANILLAR Y MANDOS

Note Notes Marka Notas	Pos. No. N. Index Pos.	N. Cod. Code No. Nr. Code Code Nr N. Cod.	Q.1à Q.1y Q.1e M.ge C.ad	DENOMINAZIONE	NAME	DESIGNATION	BESHREIBUNG	DENOMINACION	Validità Validity Validité Gültig Validez
	1	8000 75155	1	Comando gas completo	Throttle control compl.	Commande gaz compl.	Gasgriff kpl.	Accionam. acelerador compl.	
	2	8000 75310	1	Coperchio	Cover	Couvercle	Deckel	Tapa	
	3	8000 66774	2	Vite	Screw	Vis	Schraube	Tomillo	
	9	60N1 07330	2	Vite	Screw	Vis	Schraube	Tomillo	
	10	8000 76688	1	Manopola Dx.	R.H. grip	Poignée G.	Griff R.	Manopla der.	
	11	8000 75842	1	Trasmissione comando gas	Throttle wire	Fil comm. gaz	Gaszugkabel	Trans. accionam. acelerador	
	12	8000 70997	1	Trasmissione comando frizione	Clutch transm.	Transm. com. embrayage	Führungssteuer. der Kupplung	Tran. mando embrague compl.	
	13	8000 66551	1	Leva decompressore compl.	Decompression lever	Levier décompression	Dekompressions-hebel	Palanca decompressore	
WU	14	80C0 53018	1	Manubrio	Hanblebar	Guidon	Lenker	Manillar	
C	14	8000 88280	1	Manubrio	Hanblebar	Guidon	Lenker	Manillar	
R	14	8000 88280	1	Manubrio	Hanblebar	Guidon	Lenker	Manillar	
	15	8000 76687	1	Manopola Sx.	L.H. grip	Poignée G.	L. Griff	Manopla izrda.	
	16	8000 79754	1	Trasmissione decompressore	Decompression transm.	Trasm. décompression	Dekompressions Kabel	Transm. decompressore	
	17	8000 47824	1	Vite	Screw	Vis	Schraube	Tomillo	
	18	8000 38799	1	Dado	Nut	Ecrou	Mutter	Tuerca	
	19	8000 48916	1	Gruppo registro	Adjuster set	Groupe réglage	Kupplungsreglergruppe	Grupo regul.	
	20	8000 71232	1	Comando frizione compl.	Clutch control lever, assy	Levier com. embrayage compl.	Kupplungshebel, Kpl.	Palanca embrague comp.	
	22	8000 66489	1	Coprileva	Lever cover	Couvre levier	Hebeldeckel	Cubre-palanca mando embr.	
	29	8000 62728	2	Vite	Screw	Vis	Schraube	Tomillo	
	31	8000 58013	1	Cavallotto	U-bolt	Cavalier	Bügelbolzen	Caballete	
	32	8000 66487	1	Leva frizione	Clutch lever	Levier embrayage	Kupplungshebel	Palanca mando embrague	
	33	8000 66552	1	Supporto	Support	Support	Halterung	Soporte elástico	
XYD	34	8000 65437	2	Specchietto retrov. Dx. e Sx.	Driving mirror	Rétroviseur	Rückspiegel	Espejo retrovisor	
	35	8000 48918	1	Protezione	Guard	Protection	Schutz	Protección	
	38	8000 38802	1	Bariotto	Retainer	Cliquet	Sicherungsring	Barrilejo	

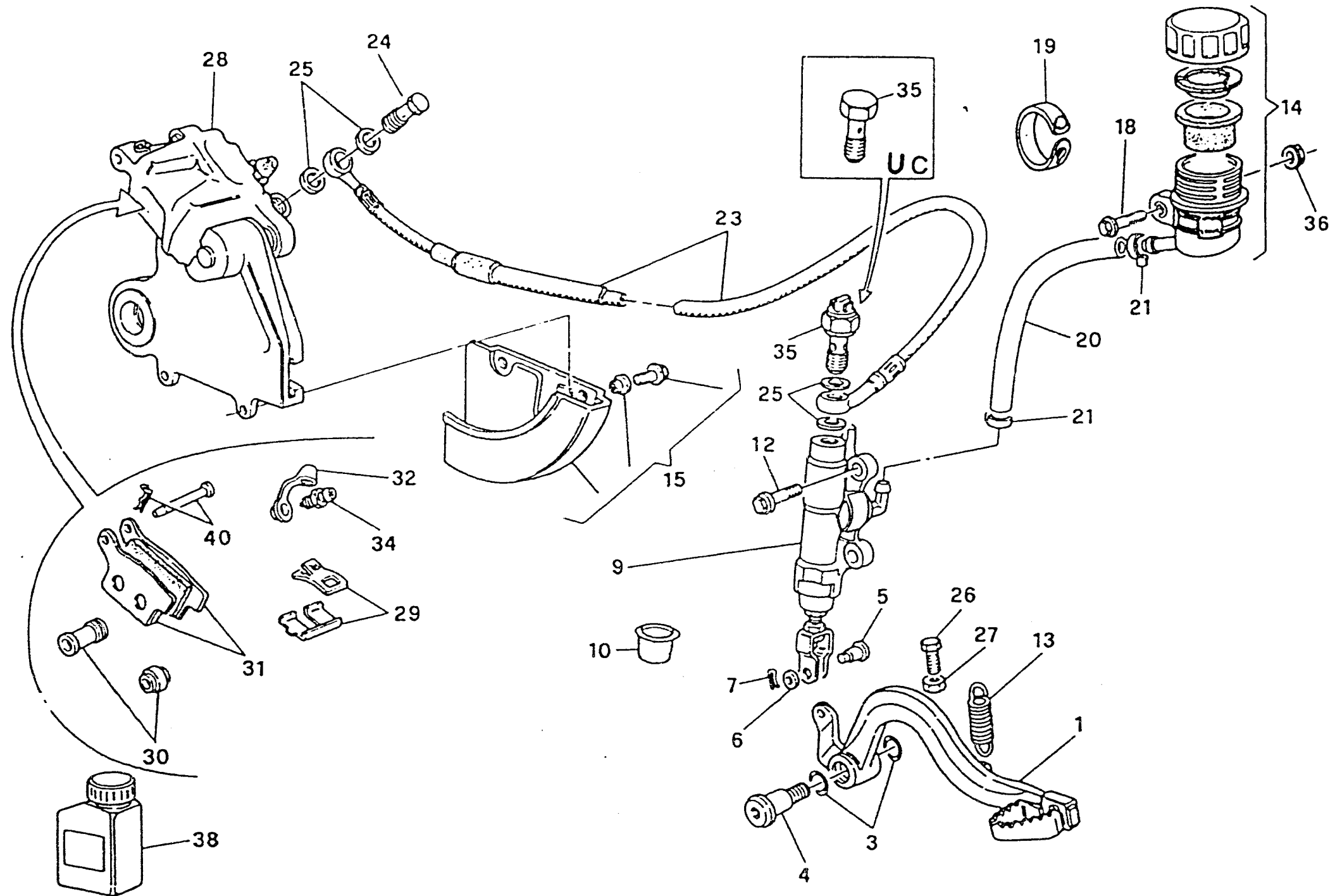



TE - TE U.S.A.
410 - 610 / 99
TC 610 / 99

TAVOLA
DRAWING
TABLE
BILD
TABLA

18

FRENO IDRAULICO POSTERIORE - REAR HYDRAULIC BRAKE
FREIN HYDRAULIQUE ARRIERE - HINTERBREMSE
FRENO HIDRAULICO TRASERO

Note Notes Mark Notas	Pos. No. N. Index Pos.	N. Cod. Code No. Nr. Code Code Nr N. Cod.	Q.tà Q.ty Q.te M.ge C.ad	DENOMINAZIONE	NAME	DESIGNATION	BESHREIBUNG	DENOMINACION	Vakna Vakny Vakné Gulig Vakoz
	1	8A00 64708	1	Leva comando freno	Brake control lever	Levier comm. frein	Bremshebel	Palanca accionamiento freno	
	2	62N1 15780	1	Rosetta ondulata	Washer	Rondeiie	Scheibe	Arandela	
	3	8000 22551	2	Anello OR	O-Ring	Bague OR	O-Ring	Anillo OR	
	4	8000 55902	1	Vite	Screw	Vis	Schraube	Tomillo	
	5	8000 70696	1	Astina	Control rod	Coulisseau	Steuerstange	Varilla	
	6	8000 56377	1	Rosetta	Washer	Rondelle	Scheibe	Arandela	
	7	64N1 20068	1	Copiglia	Split pin	Goupille	Splint	Clavija	
	9	8000 76338	1	Pompa comando freno compl.	Brake pump	Pompe frein	Bremspumpe	Bomba freno	
	10	8000 79075	1	Cuffia	Cap	Capuchons	Kappa	Gorro	
	12	8000 62726	2	Vite	Screw	Vis	Schraube	Tomillo	
	13	8000 55903	1	Molla	Spring	Ressort	Feder	Resorte	
	14	8000 61078	1	Serbatoio olio completo	Oil tank assy	Reservoir huile compl.	Öltank Kpl.	Depósito aceite completo	
R	15	8000 76289	1	Kit protezione disco	Kit guard	Kit protection	Kit Schutz	Kit protección	
	18	8000 62727	1	Vite	Screw	Vis	Schraube	Tomillo	
	19	8000 53724	1	Fascetta	Clamp	Collier	Schelle	Banda	
	20	8A00 70266	1	Tubazione	Pipe	Tuyau	Rohr	Tubo	
	21	8000 42349	1	Molletta	Spring	Ressort	Feder	Resorte	
	23	8000 78326	1	Tubo mandata olio	Pipe	Tuyau	Rohr	Tubo	
	24	8000 57155	1	Vite	Screw	Vis	Schraube	Tomillo	
	25	8000 21480	4	Rosetta di tenuta	Washer	Rondelle	Scheibe	Arandela	
	26	60N1 02511	1	Vite	Screw	Vis	Schraube	Tomillo	
	27	61N1 15062	1	Dado	Nut	Ecrou	Mutter	Tuerca	
	28	8000 77745	1	Pinza freno completa	Brake caliper assy	Pince de frein, compl.	Bremszange, Kpl.	Pinza freno compl.	
	29	8000 85932	1	Gruppo revisione mollette	Spring set	Kit revision ressort	Federsatz	Grupo revis. resorte	
	30	8000 79066	1	Gruppo revisione cuffie	Caps revision set	Groupe revision capuchons	Kappa reparatursatz	Grupo revis. gorro	
	31	8000 79072	1	Coppia pastiglie	Pads pair	Paire plaquettes	Bremsbelagpaar	Pareja pastillas	
R	31	8A00 79072	1	Coppia pastiglie	Pads pair	Paire plaquettes	Bremsbelagpaar	Pareja pastillas	
	32	8000 53259	1	Parapolvere	Dust cover	Para poussière	Staubdeckel	Tapa retención polvo	
	34	8000 60404	1	Gruppo revisione spurgo	Bleeding set	Kit de revision curage	Reinigungsatz	Grupo revis. purga	
W	35	8000 37891	1	Interruttore stop posteriore	Stop switch	Interrupteur stop	Stopschalter	Interruptor stop	
CU	35	8000 57155	1	Vite	Screw	Vis	Schraube	Tomillo	
	36	8000 44240	1	Dado	Nut	Ecrou	Mutter	Tuerca	

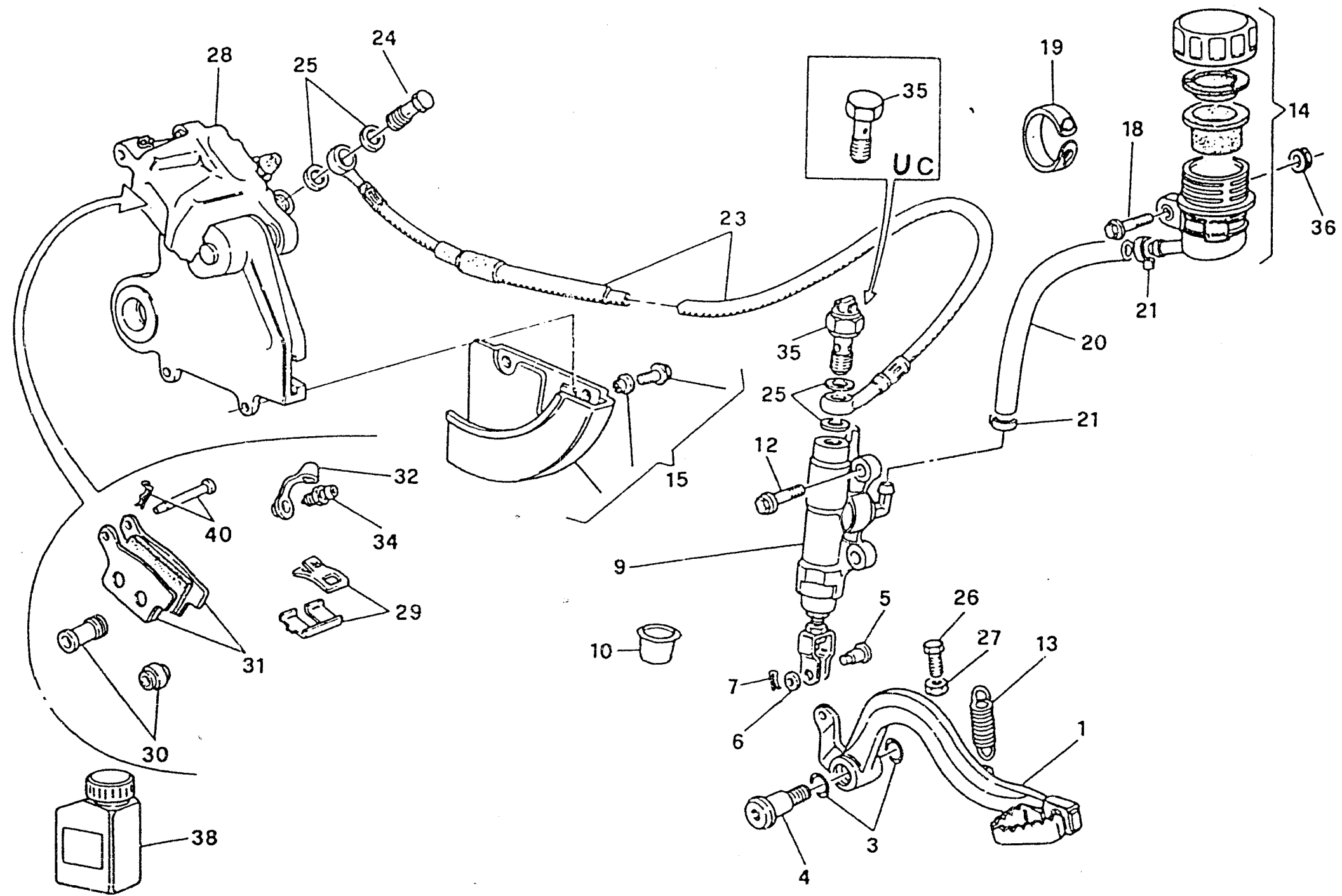



TE - TE U.S.A.
410 - 610 / 99
TC 610 / 99

TAVOLA
DRAWING
TABLE
BILD
TABLA

18

FRENO IDRAULICO POSTERIORE - REAR HYDRAULIC BRAKE
FREIN HYDRAULIQUE ARRIERE - HINTERBREMSE
FRENO HIDRAULICO TRASERO

Note Notes Marka Notas	Pos. No. Index Pos.	N. Cod. Code No. Nr. Code Code Nr N. Cod.	Q.1a Q.1y Q.1e M.ge C.ad	DENOMINAZIONE	NAME	DESIGNATION	BESHREIBUNG	DENOMINACION	Valida Valdita Valdité Gültig Validez
R	38	8000 71445	1	Olio freni	Brake oil	Huile de frein	Bremsöl	Aceite freno	
	40	8000 87153	1	Gruppo revisione perni pastiglie	Pad pin set	Kit revision pivots pastilles	Bremsbelagbolzensatz	Grupo revis. pernos pastillas	

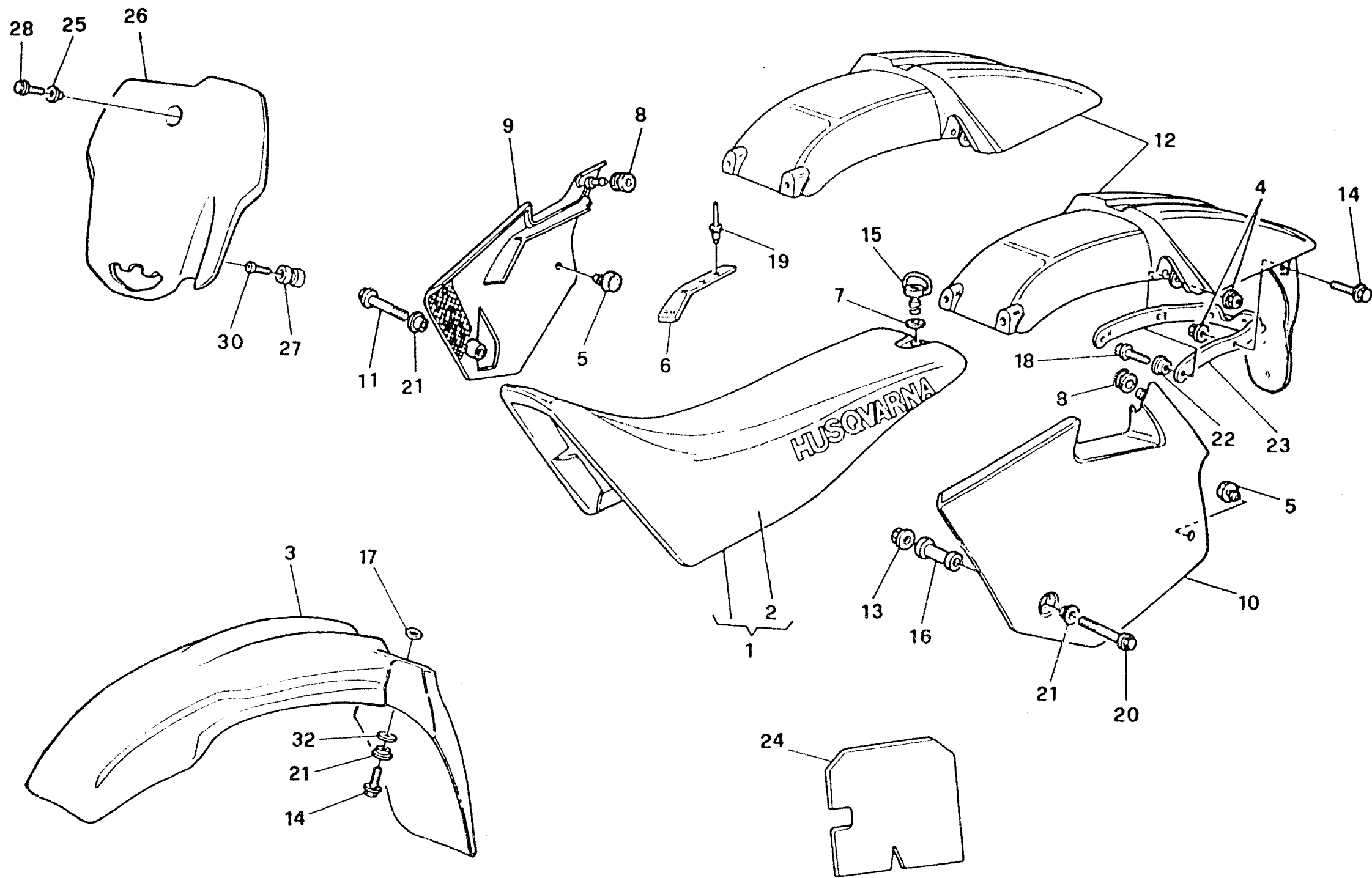



TE - TE U.S.A.
410 - 610 / 99
TC 610 / 99

TAVOLA
DRAWING
TABLE
BILD
TABLA

19

PANNELLI, PARAFANGHI, SELLA - PANEL, FENDERS, SEAT
PANNEAU, GARDE-BOUES, SIEGE - STREIFEN, KOTFLUGEL, SATTEL
PANELO, GUARDABARROS, SILLIN

Note Notes Notas	Pos. No. N. index Pos.	N. Cod. Code No. Nr. Code Code Nr N. Cod.	Q.ta Q.ty Q.1e M.ge C.ad	DENOMINAZIONE	NAME	DESIGNATION	BESCHREIBUNG	DENOMINACION	Valida Validny Valide Gültig Validez
	1	8000 90079	1	Sella	Seat	Siège	Sattel	Sillín	
	2	8000 90077	1	Rivestimento sella	Saddle covering	Revetement selle	Sattelverkleidung	Revestimiento sillín	
	3	80F0 87059	1	Parafango anteriore	Front mudguard	Garde-boue avant	Vord. Kotfluegel	Guarda-barros delantero	
XY	4	8000 44240	2	Dado	Nut	Ecrou	Mutter	Tuerca	
	5	8000 45490	2	Gommino	Rubber pad	Pièce caoutchouc	Gummistück	Junta de goma	
CU	6	8000 75941	1	Protezione	Guard	Protection	Schutz	Protección	
	7	8000 69149	4	Rosetta elastica	Spring washer	Rondelle élastique	Federscheibe	Arandela elástica	
	8	8000 18048	2	Gommino	Rubber pad	Pièce caoutchouc	Gummistück	Junta de goma	
	9	8G00 70208	1	Pannello destro	R.H. panel	Panneau, D.	Streifen, R.	Panel der.	
	10	80H0 70209	1	Pannello sinistro	L.H. panel	Panneau, G.	Streifen, L.	Panel izq.	
	11	8E00 67545	1	Vite	Screw	Vis	Schraube	Tomillo	
W	12	8A00 89851	1	Parafango posteriore	Rear mudguard	Garde-boue arriere	Hint.Kotfluegel	Guarda-barros trasero	
CU	12	8A00 89938	1	Parafango posteriore	Rear mudguard	Garde-boue arriere	Hint.Kotfluegel	Guarda-barros trasero	
	13	8000 44240	1	Dado	Nut	Ecrou	Mutter	Tuerca	
	14	8000 62728	2	Vite (fissaggio anteriore)	Screw	Vis	Schraube	Tomillo	
	14	8000 62727	4	Vite	Screw	Vis	Schraube	Tomillo	
	15	8000 69148	4	Perno	Pin	Pivot	Bolzen	Perno	
	16	1519 76703	1	Distanziale	Spacer	Entretoise	Distanzstück	Separador	
	17	8A00 07001	2	Distanziale	Spacer	Entretoise	Distanzstück	Separador	
	18	8000 62730	2	Vite	Screw	Vis	Schraube	Tomillo	
CU	19	8000 72510	1	Rivetto	Rivet	Rivet	Niet	Remache	
	20	8C00 67545	1	Vite	Screw	Vis	Schraube	Tomillo	
	21	8000 69429	6	Bussoia	Bushing	Douille	Buchse	Manguito	
	22	8000 45495	4	Bussola	Bushing	Douille	Buchse	Manguito	
XY	23	8000 72396	1	Piastra rinforzo	Plate	Plaque	Platte	Placa	
	24	8000 72348	1	Protezione	Guard	Protection	Schutz	Protección	
CU	25	8B00 69282	1	Bussoia	Bushing	Douille	Buchse	Manguito	
CU	26	80A0 87800	1	Portanumero	Number holder	Porte numero	Nummerträger	Porta numero	
CU	27	8A00 69003	2	Distanziale	Spacer	Entretoise	Distanzstück	Separador	
CU	28	8C00 67997	1	Vite	Screw	Vis	Schraube	Tomillo	
CU	30	8000 63636	2	Vite	Screw	Vis	Schraube	Tomillo	
	32	8000 56359	4	Rosetta	Washer	Rondelle	Scheibe	Arandela	

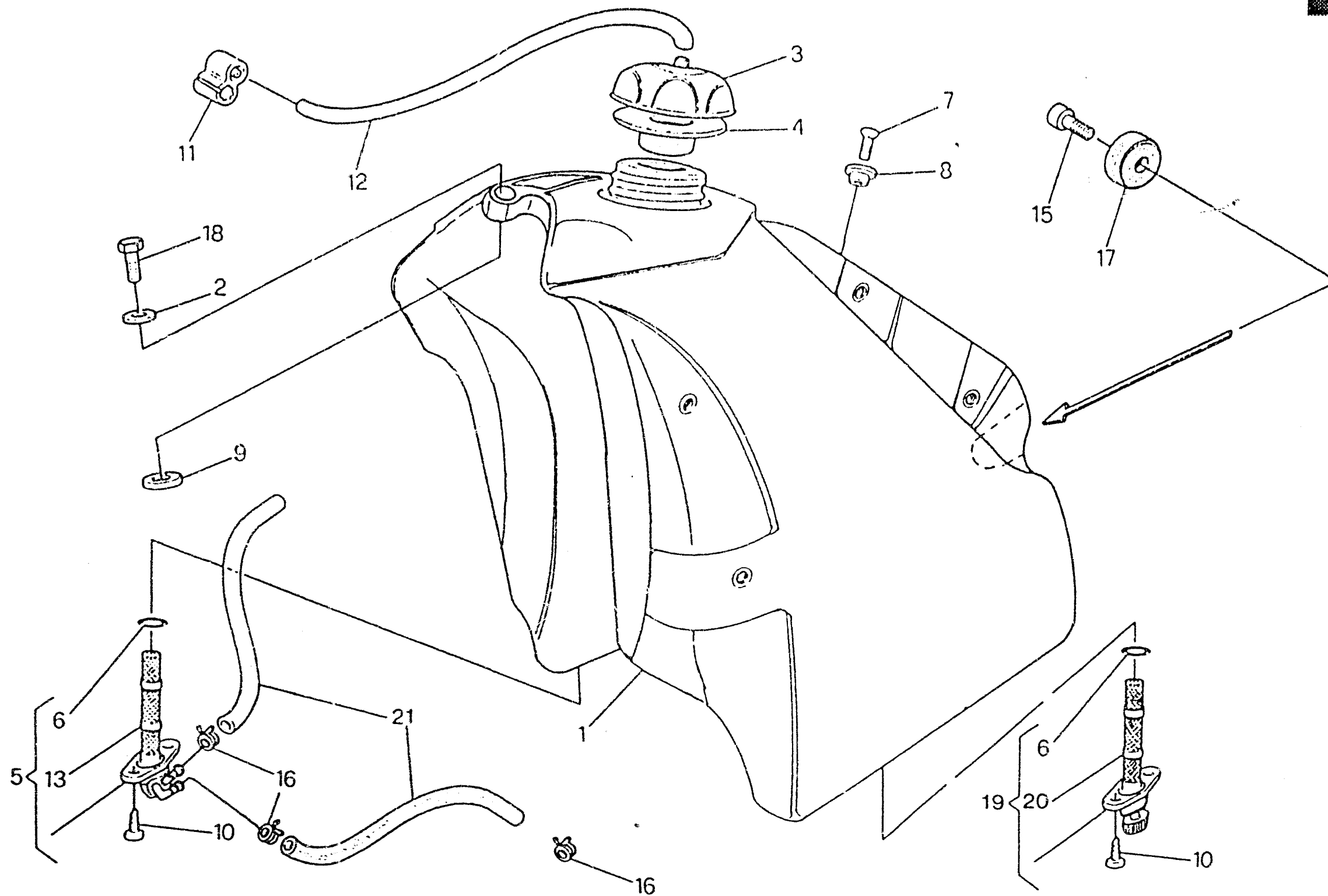



TE - TE U.S.A.
410 - 610 / 99
TC 610 / 99

TAVOLA
DRAWING
TABLE
BILD
TABLA

20

SERBATOIO - GAS TANK
RESERVOIR - KRAFTSTOFFBEHALTER
DEPOSITO

Note Notes Marka Notas	Pos. No. N. Index Pos.	N. Cod. Code No. Nr. Code Code Nr N. Cod.	Q.ta Q.ty Q.te M.ge C.ad	DENOMINAZIONE	NAME	DESIGNATION	BESHREIRUNG	DEKONINACION	Vakdrā Vakdrā Vakdrā Gurtig Vakdrā
	1	80B0 66630	1	Serbatoio carburante	Fuel tank	Réservoir à carburant	Tank	Depósito gasolina	
	2	8000 30319	1	Rosetta piana	Washer	Rondelle	Scheibe	Arandela	
	3	8000 65604	1	Tappo	Plug	Bouchon	Verschluss	Tapón	
	4	8000 56381	1	Guarnizione	Gasket	Garniture	Dichtung	Junta	
	5	8000 66648	1	Rubinetto Dx.	R.H. cock	Robinet D.	R.Kraftstoffahn	Llave de paso der.	
	6	8000 01199	2	Anello OR	O-Ring	Bague OR	O-Ring	Anillo OR	
	7	60N1 04134	1	Vite	Screw	Vis	Schraube	Tornillo	
	8	8000 66238	1	Distanziale	Spacer	Entretoise	Distanzstück	Separador	
	9	8000 61362	1	Tampone	Pad	Tampon	Stopfen	Tampón	
	10	8000 37745	4	Vite	Screw	Vis	Schraube	Tornillo	
	12	8B00 38752	1	Tubetto sfiato	Battery breather pipe	Event batterie	Batterieentlüfter	Tubo de purga batería	
	13	8000 38748	1	Filtro benzina	Fuel filter	Filtre essence	Benzinfilter	Filtro gasolina	
	15	60N1 07350	2	Vite	Screw	Vis	Schraube	Tornillo	
	16	8000 18922	3	Anello elastico	Split ring	Anneau ressort	Sprengring	Anillo elástico	
	17	8000 40813	2	Tampone	Pad	Tampon	Stopfen	Tampón	
	18	8000 62725	1	Vite	Screw	Vis	Schraube	Tornillo	
	19	8000 67440	1	Rubinetto Sx.	L.H. cock	Robinet G.	L.Kraftstoffahn	Llave de paso izq.	
	20	8000 67700	1	Filtro benzina	Fuel filter	Filtre essence	Benzinfilter	Filtro gasolina	
	21	1514 05711	2	Condotto benzina	Pipe	Tuyau	Rohr	Tubo	

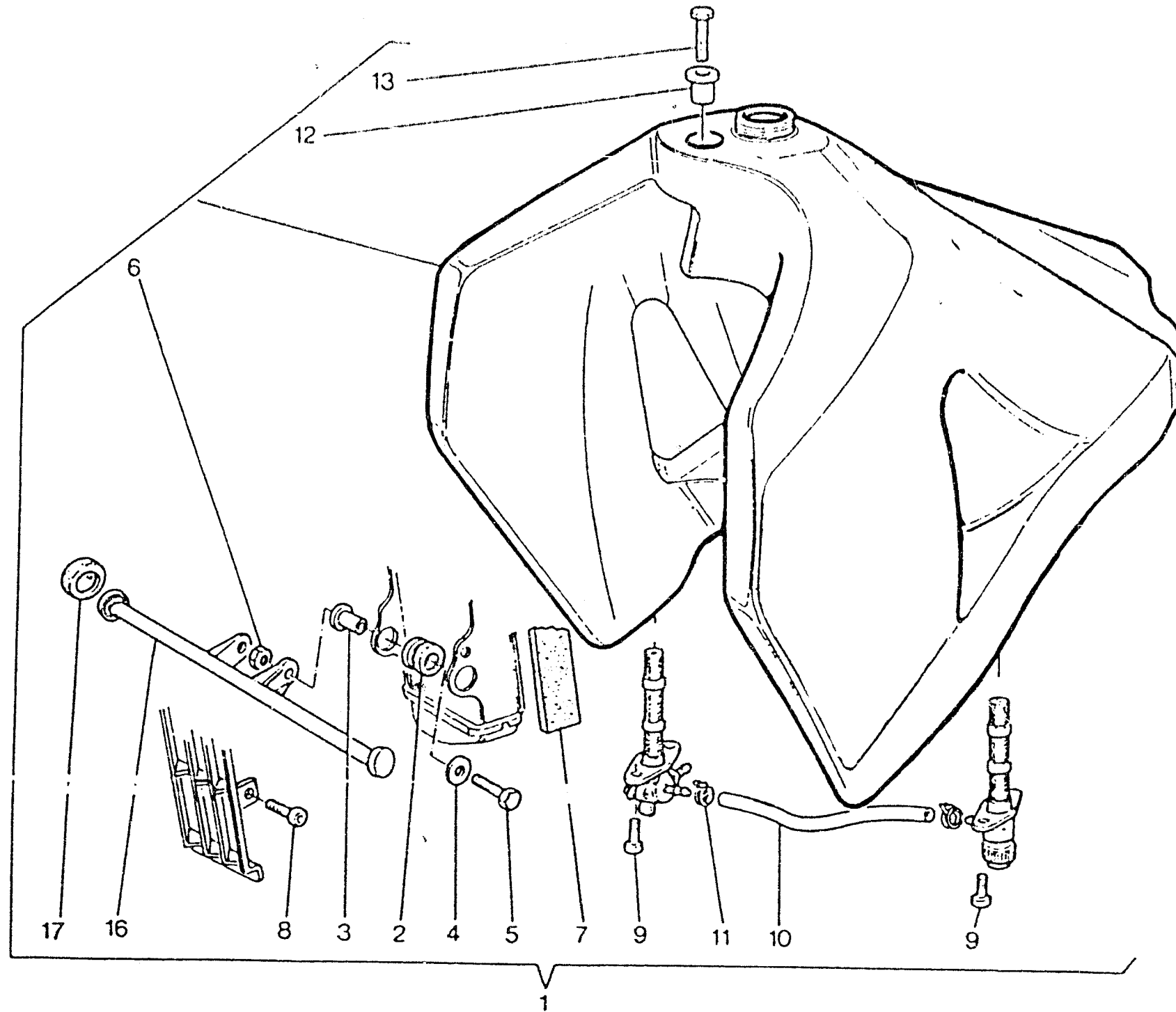



TE - TE U.S.A.
410 - 610 / 99
TC 610 / 99

TAVOLA
DRAWING
TABLE
BILD
TABLA

20A

SERBATOIO MAGGIORATO - LARGE GAS TANK
RESERVOIR DE PLUS GRANDE CAPACITE - UEBERDIMENSIONIERTER BEHALTER
DEPOSITO AMBLIADO

Note Notes Marken Notas	Pcs. No. Index Pos.	N. Cod. Code No. Nr. Code Code Nr N. Cod.	Q.tà Q.ty Q.te M.ge C.ad	DENOMINAZIONE	NAME	DESIGNATION	BESHREIBUNG	DENOMINACION	VANDRA Vandry Vandré Gullig Vandez
	1	8000 80257	1	Kit serbatoio carburante magg.	Kit fuel tank oversize	Gr. réservoir à carburant major.	MaßTank Gruppe	Kit depósito gasolina aument.	
	2	8000 59803	2	Gommino	Rubber pad	Pièce caoutchouc	Gummistück	Junta de goma	
	3	8000 59802	6	Bussola	Bushing	Douille	Buchse	Manguito	
	4	8000 59801	2	Rosetta	Washer	Rondelle	Scheibe	Arandela	
	5	8000 62728	2	Vite	Screw	Vis	Schraube	Tomillo	
	6	8000 44240	1	Dado	Nut	Ecrou	Mutter	Tuerca	
	7	8000 60925	1	Spessore	Spacer	Entretoise	Distanzstück	Separador	
	8	8000 62725	2	Vite	Screw	Vis	Schraube	Tomillo	
	9	8000 62725	2	Vite	Screw	Vis	Schraube	Tomillo	
	10	1514 05704	2	Condotto benzina	Pipe	Tuyau	Rohr	Tube	
	11	8000 18922	3	Anello elastico	Split ring	Anneau ressort	Sprengring	Anillo elástico	
	12	8A00 59802	6	Bussola	Bushing	Douille	Buchse	Manguito	
	13	8A00 67545	2	Vite	Screw	Vis	Schraube	Tomillo	
	16	8000 72950	1	Piastra	Plate	Plaque	Platte	Placa	
	17	8000 41986	2	Gommino	Rubber pad	Pièce caoutchouc	Gummistück	Junta de goma	

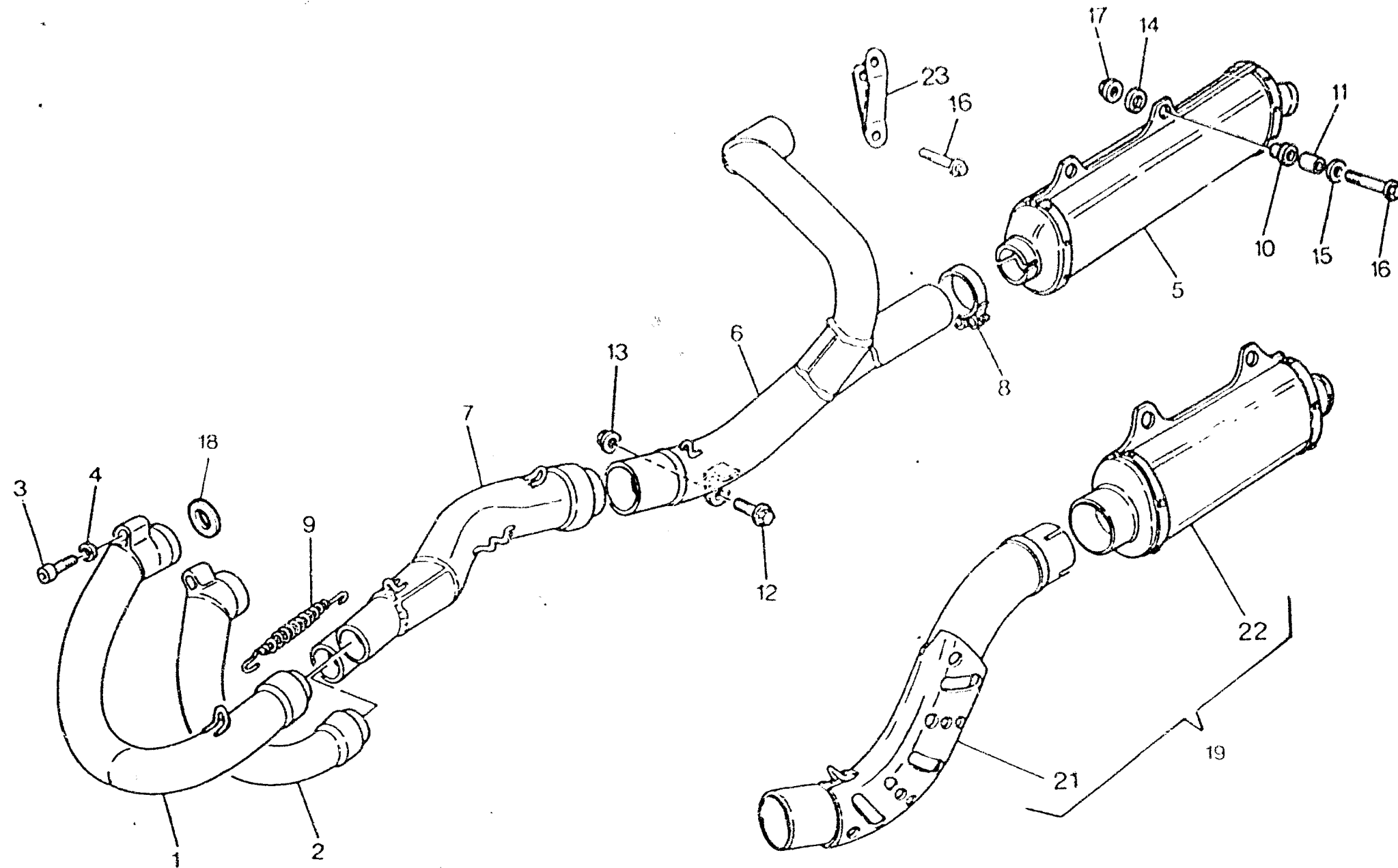



TE - TE U.S.A.
410 - 610 / 99
TC 610 / 99

TAVOLA
DRAWING
TABLE
BILD
TABLA

21

SCARICO - EXHAUST SYSTEM
TUYAU D'ÉCHAPPEMENT - AUSPUFFROHR
TUBO DE ESCAPE

Note Notes Marku Notas	Pos. No. Index Pos.	N. Cod. Code No. Nr. Code Code Nr N. Cod.	Q.tà Q.ty Q.te M.ge C.ad	DENOMINAZIONE	NAME	DESIGNATION	BESCHREIBUNG	DENOMINACION	Valdņa Vaidņā Gūnģ Valdež
	1	8B00 71233	1	Tubo di scarico Dx (610)	R.H. exhaust pipe (610)	Tuyau d'échapp. D.. (610)	Auspuffrohr R.. (610)	Tubo de escape der.(610)	
	1	8C00 71233	1	Tubo di scarico Dx (410)	R.H. exhaust pipe (410)	Tuyau d'échapp. D.. (410)	Auspuffrohr R.. (410)	Tubo de escape der.(410)	
	2	8B00 71234	1	Tubo di scarico Sx (610)	L.H. exhaust pipe. (610)	Tuyau d'échapp. G.. (610)	Auspuffrohr L.. (610)	Tubo de escape izq. (610)	
	2	8C00 71234	1	Tubo di scarico Sx (410)	L.H. exhaust pipe. (410)	Tuyau d'échapp. G.. (410)	Auspuffrohr L.. (410)	Tubo de escape izq. (410)	
	3	60N1 02511	2	Vite	Screw	Vis	Schraube	Tomillo	
	4	8000 45499	2	Rosetta	Washer	Rondelle	Scheibe	Arandela	
W	5	8000 80384	2	Silenziatore (610)	Exhaust silencer (610)	Silencieux d'échappement (610)	Schalldämpfer (610)	Silenciador de escape (610)	
W	5	8000 89588	2	Silenziatore (410)	Exhaust silencer (410)	Silencieux d'échappement (410)	Schalldämpfer (410)	Silenciador de escape (410)	
U	5	8000 80428	2	Silenziatore (610)	Exhaust silencer (610)	Silencieux d'échappement (610)	Schalldämpfer (610)	Silenciador de escape (610)	
U	5	8B00 80428	2	Silenziatore (410)	Exhaust silencer (410)	Silencieux d'échappement (410)	Schalldämpfer (410)	Silenciador de escape (410)	
WU	6	8000 70378	1	Raccordo tubi scarico	Union exhaust pipe	Raccord tuyau d'échapp.	Anschluss Auspuffrohr	Empalme tubo de escape	
	7	8000 71557	1	Raccordo tubi scarico anter.	Front union exhaust pipe	Raccord tuyau d'échapp. avant	Vorderanschluss Auspuffrohr	Empalme tubo de escape dela.	
WU	8	8000 72411	2	Fascetta	Clamp	Collier	Schelle	Banda	
C	8	8A00 72411	1	Fascetta	Clamp	Collier	Schelle	Banda	
UR	8	8A00 72411	1	Fascetta	Clamp	Collier	Schelle	Banda	
	9	8000 67496	3	Molla	Spring	Ressort	Feder	Resorte	
	10	1514 10702	4	Distanziale in gomma	Rubber spacer	Entretoise en caoutchouc	Gummi Distanzstück	Separador de goma	
	11	8000 70379	4	Distanziale	Spacer	Entretoise	Distanzstück	Separador	
	12	8000 69056	1	Vite	Screw	Vis	Schraube	Tomillo	
	13	8000 43928	1	Dado	Nut	Ecrou	Mutter	Tuerca	
	14	1513 41401	4	Rosetta in gomma	Rubber washer	Rondelle en caoutchouc	Gummischeibe	Arandela de goma	
	15	1513 74301	4	Rosetta piana	Washer	Rondelle	Scheibe	Arandela	
W	16	8A00 67545	4	Vite	Screw	Vis	Schraube	Tomillo	
CU	16	8A00 67545	2	Vite	Screw	Vis	Schraube	Tomillo	
	17	8000 44240	4	Dado	Nut	Ecrou	Mutter	Tuerca	
	18	8AA0 21626	2	Rosetta (410)	Washer (410)	Rondelle (410)	Scheibe (410)	Arandela (410)	
UR	19	8000 72281	1	Ass. kit tubo di scarico singolo	Single exhaust pipe kit	Set tuyau d'échapp. single	Einzel Auspuffrohr Gruppe	Kit cade tubo de escape	
CU	21	8000 72282	1	Raccordo tubi scarico	Union exhaust pipe	Raccord tuyau d'échapp.	Anschluss Auspuffrohr	Empalme tubo de escape	
CU	22	8000 72283	1	Silenziatore	Exhaust silencer	Silencieux d'échappement	Schalldämpfer	Silenciador de escape	
S	22	8A00 72283	1	Silenziatore	Exhaust silencer	Silencieux d'échappement	Schalldämpfer	Silenciador de escape	
CU	23	8000 71186	1	Piastrina	Plate	Plaquette	Plättchen	Placa	

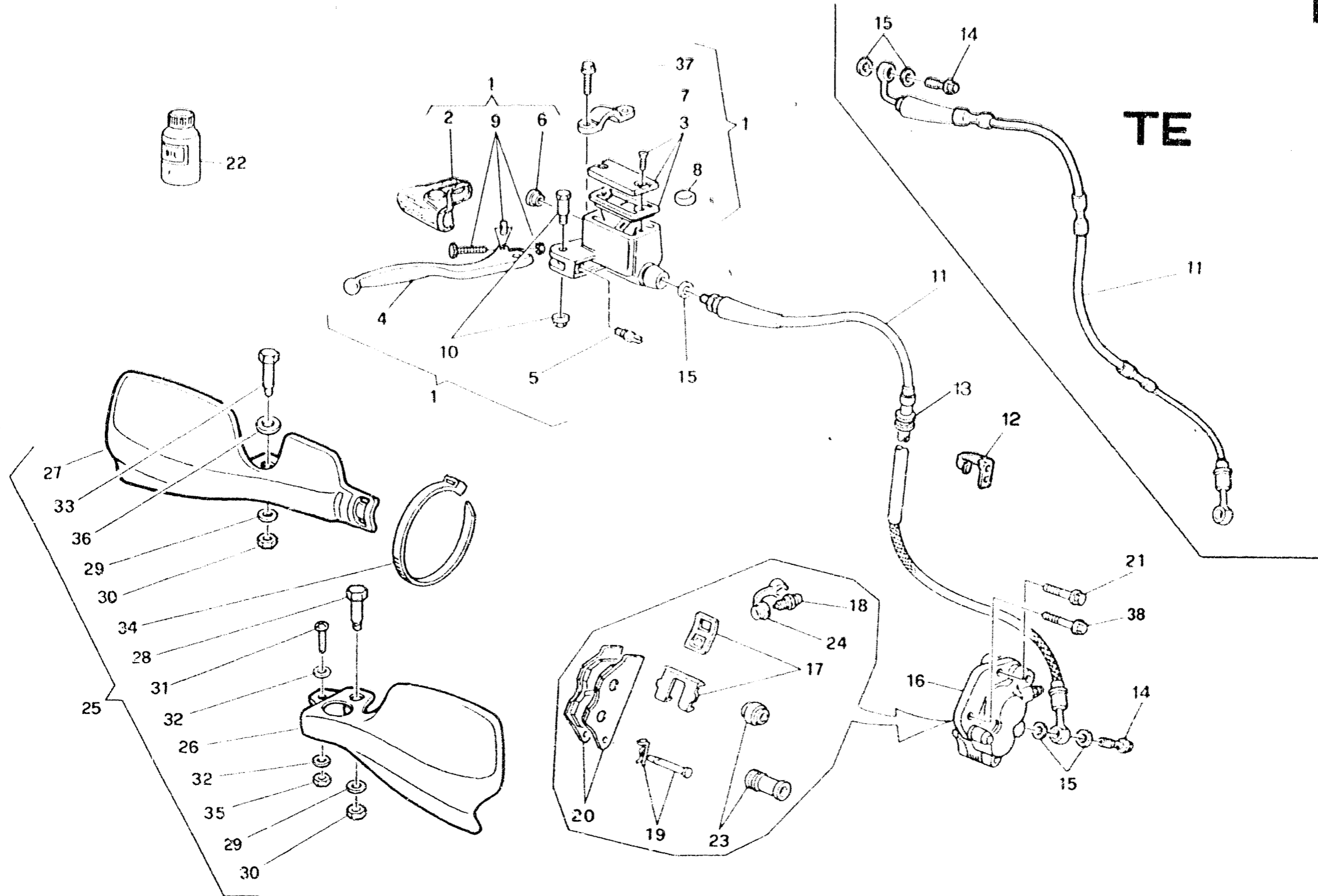



TE - TE U.S.A.
410 - 610 / 99
TC 610 / 99

TAVOLA
DRAWING
TABLE
BILD
TABLA

22

FRENO IDRAULICO ANTERIORE - FRONT HYDRAULIC BRAKE
FREIN HYDRAULIQUE AVANT - VORTERBREMSE
FRENO HIDRAULICO DELANTERA

Note Notes Notas	Poe. No. N. Index Pos.	N. Cod. Code No. Nr. Code Code Nr N. Cod.	Q. la Q. ty Q. te M. ge C. ad	DENOMINAZIONE	NAME	DESIGNATION	BESCHREIBUNG	DE NOMBRACION	VandA Vandhy VandAA Gung Vandaz
	1	8000 77740	1	Pompa comando freno ant.	Brake pump	Pompe frein	Bremspumpe	Bomba freno	
	2	8000 79098	1	Kit cappuccio	Cap kit	Kit capuchon	Kappe Gruppe	Kit capuchón	
	3	8000 79069	1	Kit tappo	Plug kit	Bouchon kit	Verschluss Gruppe	Kit tapón	
	4	8000 79096	1	Kit leva	Lever set	Kit revision levier	Hebelbolzensatz	Grupo revis. perno	
	5	8000 79071	1	Interruttore stop	Stop switch	Interrupteur stop	Stopschalter	Interruptor stop	
	6	8000 49654	1	Oblò	Inspection plug	Capuchon de inspection	Stopfen	Portilla	
	7	8000 79097	1	Cavallotto	U-bolt	Cavalier	Bügelbolzen	Caballete	
	8	8000 79099	1	Antiemulsione	Antiemulsion	Antiemulsion	Emulsionswidner	Antiemulsion	
	9	8000 79100	1	Kit regolazione leva	Lever set	Kit levier	Hebel gruppe.	Grupo palanca	
	10	8000 79070	1	Perno leva	Pin lever	Goujon levier	Bolzen Hebel	Perno palanca	
W	11	8000 89915	1	Tubo mandata olio	Pipe	Tuyau	Rohr	Tubo	
CU	11	8A00 77741	1	Tubo mandata olio	Pipe	Tuyau	Rohr	Tubo	
W	12	8000 90104	1	Piastrina	Plate	Plaquette	Plättchen	Placa	
CU	12	8000 72022	1	Piastrina	Plate	Plaquette	Plättchen	Placa	
	13	8000 71806	1	Guida cavo	Cable guide	Guide câble	Kabelführung	Guía-cable	
W	14	8000 57155	2	Bocchettone	Pipe union	Goulotte	Stutzen	Boca	
CU	14	8000 57155	1	Bocchettone	Pipe union	Goulotte	Stutzen	Boca	
W	15	8000 21480	4	Rosetta di tenuta	Washer	Rondelle	Scheibe	Arandela	
CU	15	8000 21480	3	Rosetta di tenuta	Washer	Rondelle	Scheibe	Arandela	
	16	8000 85998	1	Pinza freno	Brake caliper	Etrier frein	Bremssattel	Pinza	
	17	8000 79065	1	Kit mollette	Spring kit	Kit ressort	Federgruppe	Grupo resorte	
	18	8000 60404	1	Gruppo revisione spurgo	Bleeding set	Kit de revision curage	Reinigungsatz	Grupo revis. purga	
	19	8000 85999	1	Kit perni pastiglie	Pin kit	Kit pivot	Bolzengruppe	Grupo perno	
	20	8A00 74181	1	Coppia pastiglie	Pads pair	Paire plaquettes	Bremsbelagpaar	Pareja pastillas	
	21	8000 62733	1	Vite	Screw	Vis	Schraube	Tomillo	
R	22	8000 71445	1	Olio freni	Brake oil	Huile frein	Bremsöl	Acete freni	
	23	8000 79066	1	Gruppo revisione cuffie	Caps revision set	Groupe revision capuchons	Kappa reparatursatz	Grupo revis. gorro	
	24	8000 53259	1	Parapolvere	Dust cover	Para poussière	Staubdeckel	Tapa retención polvo	
R	25	8A00 86526	1	Ass. kit paramani compl.	Guards kit	Kit protection	Schutzgruppe Kpl	Grupo protección	
R	26	80A0 86525	1	Paramani Sx	L.H. guard	Protection G.	Schutz L.	Protección izquierda	
R	27	80A0 86523	1	Paramani Dx	R.H. guard	Protection D.	Schutz R.	Protección derecha	
R	28	8000 86522	1	Vite	Screw	Vis	Schraube	Tomillo	

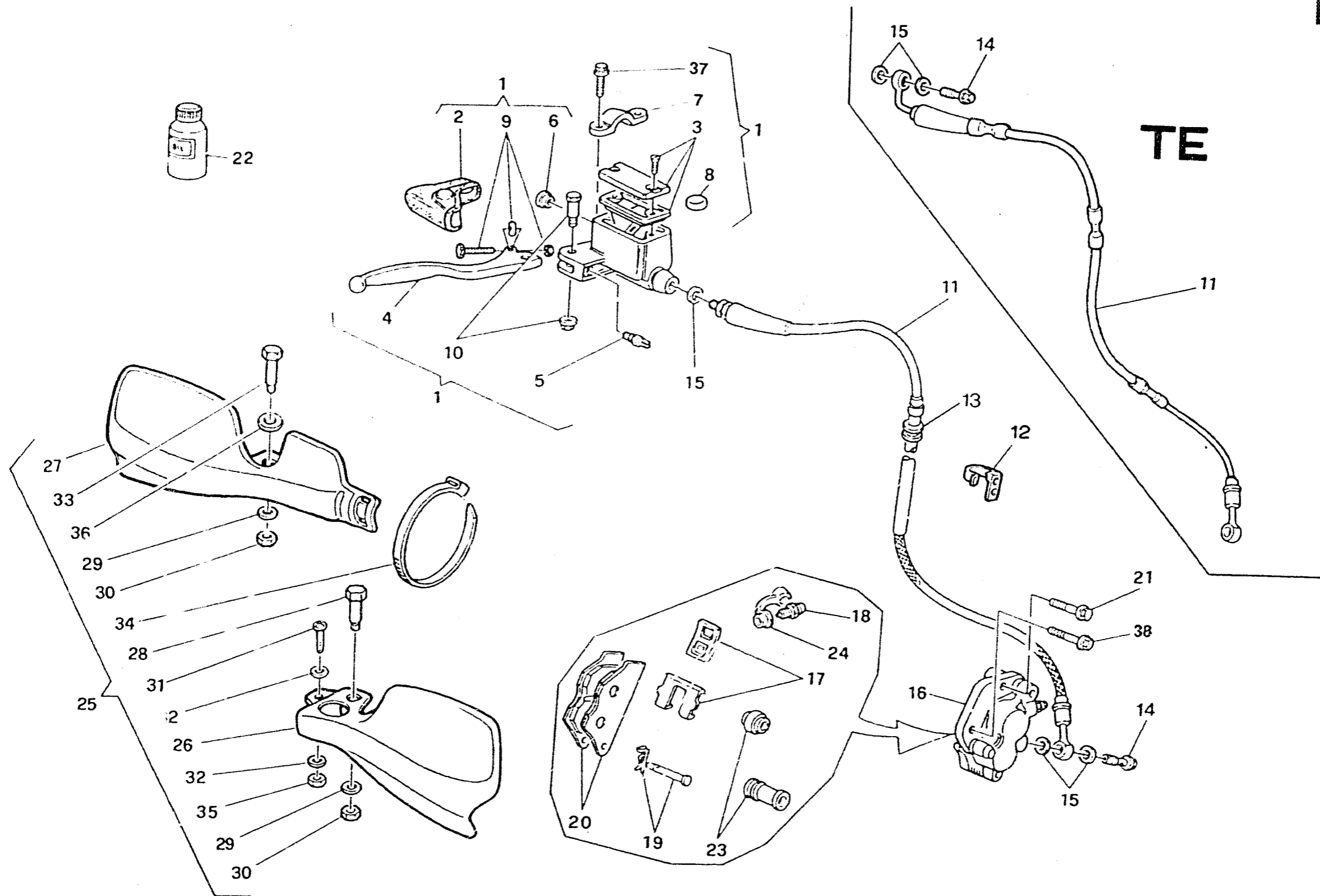



TE - TE U.S.A.
410 - 610 / 99
TC 610 / 99

TAVOLA
DRAWING
TABLE
BILD
TABLA

22

FRENO IDRAULICO ANTERIORE - FRONTHYDRAULIC BRAKE
FREIN HYDRAULIQUE AVANT- VORTERBREMSE
FRENO HIDRAULICO DELANTERA

Note Notes Marka Notas	Pos. No. N. Index Pos.	N. Cod. Code No. Nr. Code Code Nr N. Cod.	Q.tà Q.ty Q.té M.ge C.ad	DENOMINAZIONE	NAME	DESIGNATION	BESHREIBUNG	DENOMINACION	Validità Validity Validité Gültig Validez
R	29	8000 56359	2	Rosetta	Washer	Rondelle	Scheibe	Arandela	
R	30	8000 61313	2	Dado	Nut	Ecrou	Mutter	Tuerca	
R	31	8CA0 50798	1	Vite	Screw	Vis	Schraube	Tomillo	
R	32	8000 47662	2	Rosetta	Washer	Rondelle	Scheibe	Arandela	
R	33	8000 86515	1	Vite	Screw	Vis	Schraube	Tomillo	
R	34	8000 56444	1	Fascetta	Clamp	Collier	Schelle	Abrazadera	
R	35	61N1 15191	1	Dado	Nut	Ecrou	Mutter	Tuerca	
R	36	62N1 15506	1	Rosetta	Washer	Rondelle	Scheibe	Arandela	
	37	8000 62729	2	Vite	Screw	Vis	Schraube	Tomillo	
	38	8000 62795	1	Vite	Screw	Vis	Schraube	Tomillo	

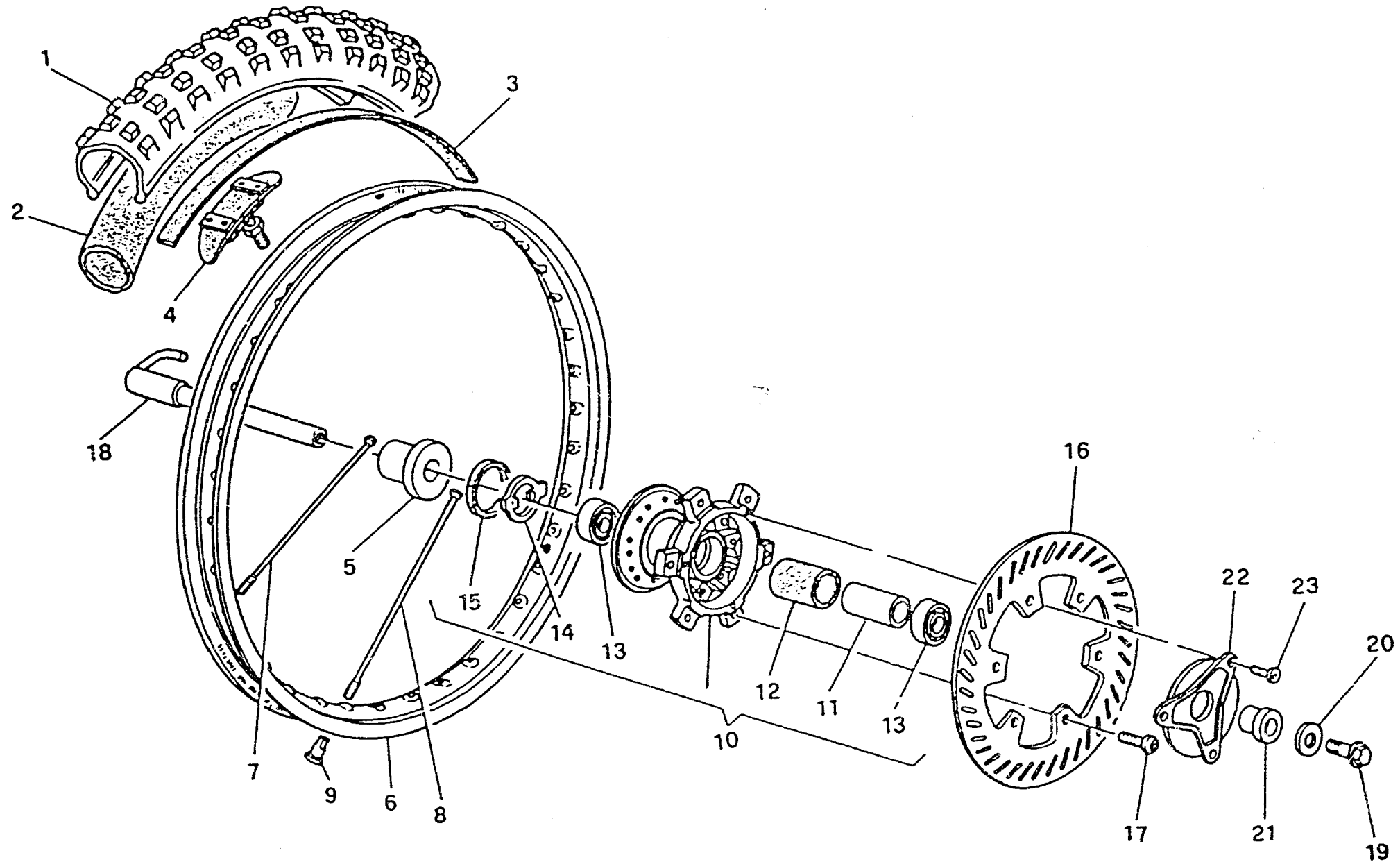



TE - TE U.S.A.
410 - 610 / 99
TC 610 / 99

TAVOLA
DRAWING
TABLE
BILD
TABLA

22A

RUOTA ANTERIORE - FRONT WHEEL
ROUE AV. - VORTERRAD
RUEDA DELANTERA

Note Notes Marka Notas	Pos. No. N. Index Pos.	N. Cod. Code No. Nr. Code Code Nr N. Cod.	Q.tà Q.ty Q.te M.ge C.ad	DENOMINAZIONE	NAME	DESIGNATION	BESHREIBUNG	DENOMINACION	Valdība Valdība Valdība Gutīg Valdēz
WUN	1	8A00 67422	1	Pneumatico 90/90-21" Michelin	Tyre	Pneu	Reifen	Neumático	
WUN	1	8C00 67422	1	Pneumatico 90/90-21" Pirelli	Tyre	Pneu	Reifen	Neumático	
CN	1	8000 67422	1	Pneumatico 90/90-21" Pirelli	Tyre	Pneu	Reifen	Neumático	
N	2	8000 18648	1	Camera d'aria Pirelli	Air tube	Chambre à air	Luftschlauch	Cámara de aire con válvula	
WUN	2	8A00 18648	1	Camera d'aria Michelin	Air tube	Chambre à air	Luftschlauch	Cámara de aire con válvula	
	3	8000 13346	1	Fascia copriraggi	Rim strip	Bande	Band	Banda	
	4	8000 49036	1	Staffa fermacopertone	Bracket	Etrier	Buegel	Brida	
CU	5	8000 77749	1	Distanziale	Spacer	Entretoise	Distanzstück	Separador	
	6	8000 53504	1	Cerchio WM 1/1,6x21"	Rim	Jante	Felge	Llanta	
WU	7	8000 76298	18	Raggio destro	Spoke R.	Bras D.	Speiche R.	Radio der.	
C	7	8000 76294	18	Raggio destro	Spoke R.	Bras D.	Speiche R.	Radio der.	
WU	8	8000 76297	18	Raggio sinistro	Spoke L.	Bras G.	Speiche L.	Radio izq.	
C	8	8000 76295	18	Raggio sinistro	Spoke L.	Bras G.	Speiche L.	Radio izq.	
WU	9	69N4 29004	36	Nipplo	Nipple	Nipple	Nippel	Nipple	
C	9	69N4 29005	36	Nipplo	Nipple	Nipple	Nippel	Nipple	
WU	10	8000 77744	1	Mozzo completo	Hub assy	Moyeau compl.	Radnabe, Kpl.	Cubo compl.	
C	10	8000 77748	1	Mozzo completo	Hub assy	Moyeau compl.	Radnabe, Kpl.	Cubo compl.	
	11	8A00 74718	1	Distanziale	Spacer	Entretoise	Distanzstück	Separador	
	12	1516 21501	1	Portadistanziale	Spacer holder	Porte-entretoise	Abstandstuckhalter	Porta-distancial	
	13	8000 39651	2	Cuscinetto a sfere	Ball bearing	Roulement à billes	Kugellager	Cojinete de bolas	
Y	14	8000 77884	1	Anello trascinatore	Ring	Bague	Ring	Anillo	
	15	8000 51957	1	Anello di tenuta	Seal ring	Bague d'étanchéité	Dichtungsring	Anillo de retención	
	16	8000 73226	1	Disco freno	Brake disc	Disque frein	Bremsscheibe	Disco freno	
	17	8A00 55241	6	Vite	Screw	Vis	Schraube	Tomillo	
WU	18	8000 77699	1	Perno ruota	Pin	Pivot	Bolzen	Perno ruoda	
C	18	8A00 75042	1	Perno ruota	Pin	Pivot	Bolzen	Perno ruoda	
	19	8000 48773	1	Vite	Screw	Vis	Schraube	Tomillo	
	20	8000 48772	1	Rosetta piana	Washer	Rondelle	Scheibe	Arandela	
	21	8000 75043	1	Distanziale	Spacer	Entretoise	Distanzstück	Separador	
	22	8B00 65572	1	Coperchio parapolvere	Dust cover	Pare poussière	Staubdeckel	Tapa retención polvo	
	23	8A00 62129	3	Vite	Screw	Vis	Schraube	Tomillo	

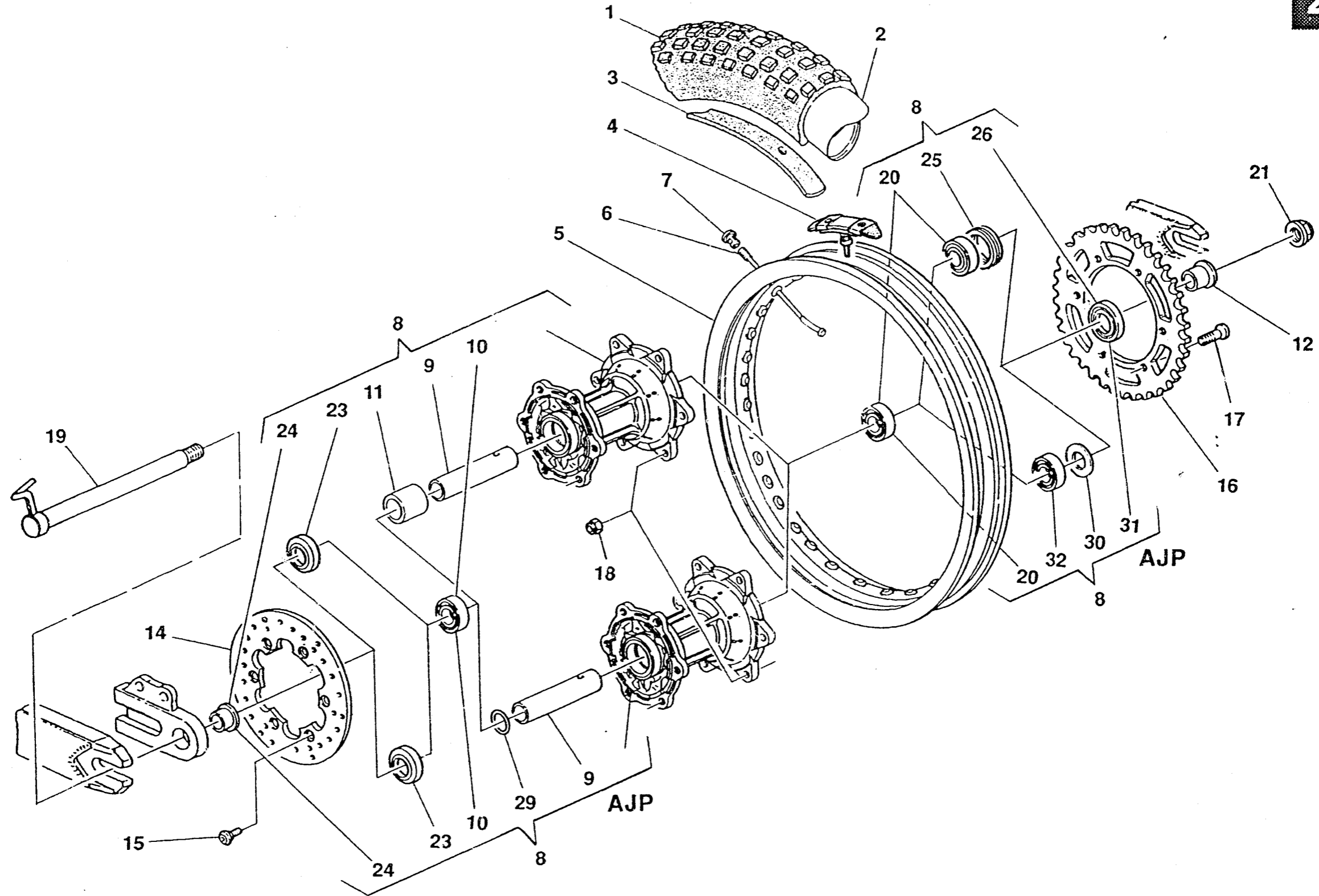



TE - TE U.S.A.
410 - 610 / 99
TC 610 / 99

TAVOLA
DRAWING
TABLE
BILD
TABLA

23

RUOTA POSTERIORE - REAR WHEEL
ROUE ARRIERE - HINTERRAD
RUEDA TRASERA

Note Notes Marka Notas	Pos. No. Index Pos.	N. Cod. Code No. Nr. Code Code Nr N. Cod.	Q.1a Q.1y Q.1e M.ge C.ad	DENOMINAZIONE	NAME	DESIGNATION	BESHREIBUNG	DENOMINACION	Validità Validité Gültig Validez
NW	1	8C00 61348	1	Pneumatico 140/80-18" Pirelli	Tyre	Pneu	Reifen	Neumático	
NW	1	8A00 61348	1	Pneumatico 140/80-18" Michelin	Tyre	Pneu	Reifen	Neumático	
NC	1	8000 61752	1	Pneumatico 130/80-19" Pirelli	Tyre	Pneu	Reifen	Neumático	
NW	2	8000 33607	1	Camera d'aria Pirelli	Air tube	Chambre à air	Luftschlauch	Cámara de aire con válvula	
NW	2	8B00 33607	1	Camera d'aria Michelin	Air tube	Chambre à air	Luftschlauch	Cámara de aire con válvula	
NC	2	8000 60196	1	Camera d'aria Pirelli	Air tube	Chambre à air	Luftschlauch	Cámara de aire con válvula	
W	3	8000 01688	1	Fascia copriraggi	Rim strip	Bande	Band	Banda	
C	3	8000 10777	1	Fascia copriraggi	Rim strip	Bande	Band	Banda	
W	4	8000 50217	1	Staffa pneumatico	Bracket	Etrier	Buegel	Brida	
C	4	8000 54073	1	Staffa pneumatico	Bracket	Etrier	Buegel	Brida	
W	5	8000 64886	1	Cerchio	Rim	Jante	Felge	Llanta	
C	5	8000 58929	1	Cerchio	Rim	Jante	Felge	Llanta	
WU	6	8000 76299	36	Raggio	Spoke	Bras	Speiche	Radio	
WU	6	8000 90080	18	Raggio Dx (AJP)	R.H. spoke (AJP)	Bras D. (AJP)	Speiche Rechte (AJP)	Radio derecho (AJP)	
WU	6	8000 90081	18	Raggio Sx (AJP)	L.H. spoke (AJP)	Bras G. (AJP)	Speiche Linke (AJP)	Radio izquierdo (AJP)	
C	6	8000 76296	36	Raggio	Spoke	Bras	Speiche	Radio	
C	6	8000 90192	18	Raggio Dx (AJP)	R.H. spoke (AJP)	Bras D. (AJP)	Speiche Rechte (AJP)	Radio derecho (AJP)	
C	6	8000 90193	18	Raggio Sx (AJP)	L.H. spoke (AJP)	Bras G. (AJP)	Speiche Linke (AJP)	Radio izquierdo (AJP)	
	7	69N4 29005	36	Nipplo	Nipple	Nipple	Nippel	Nipple	
A	8	8000 69165	1	Mozzo completo	Hub assy	Moyeau compl.	Radnabe, Kpl.	Cubo compl.	
A	8	8000 89570	1	Mozzo completo (AJP)	Hub assy (AJP)	Moyeau compl. (AJP)	Radnabe, Kpl. (AJP)	Cubo compl. (AJP)	
	9	8A00 64983	1	Distanziale	Spacer	Entretoise	Distanzstück	Separador	
	9	8B00 64983	1	Distanziale (AJP)	Spacer (AJP)	Entretoise (AJP)	Distanzstück (AJP)	Separador (AJP)	
	10	8000 55876	1	Cuscinetto	Bearing	Roulement	Kugellager	Cojinete	
	11	8000 61064	1	Porta distanziale	Spacer	Entretoise	Distanzstück	Separador	
	12	8000 64985	1	Distanziale	Spacer	Entretoise	Distanzstück	Separador	
	12	8000 89574	1	Distanziale (AJP)	Spacer (AJP)	Entretoise (AJP)	Distanzstück (AJP)	Separador (AJP)	
	14	8A00 55858	1	Disco freno	Brake disc	Disque frein	Bremsscheibe	Disco freno	
	15	8000 55878	6	Vite	Screw	Vis	Schraube	Tornillo	
WU	16	8000 60062	1	Corona Z = 48	Ring gear	Couronne	Kranz	Corona	
AWU	16	8B00 91498	1	Corona Z = 48 (SUPER SPROX)	Ring gear Z = 48 (SUPER SPROX)	Couronne Z = 48 (SUPER SPROX)	Kranz Z = 48 (SUPER SPROX)	Corona Z = 48 (SUPER SPROX)	
C	16	8000 60066	1	Corona Z = 52	Ring gear	Couronne	Kranz	Corona	

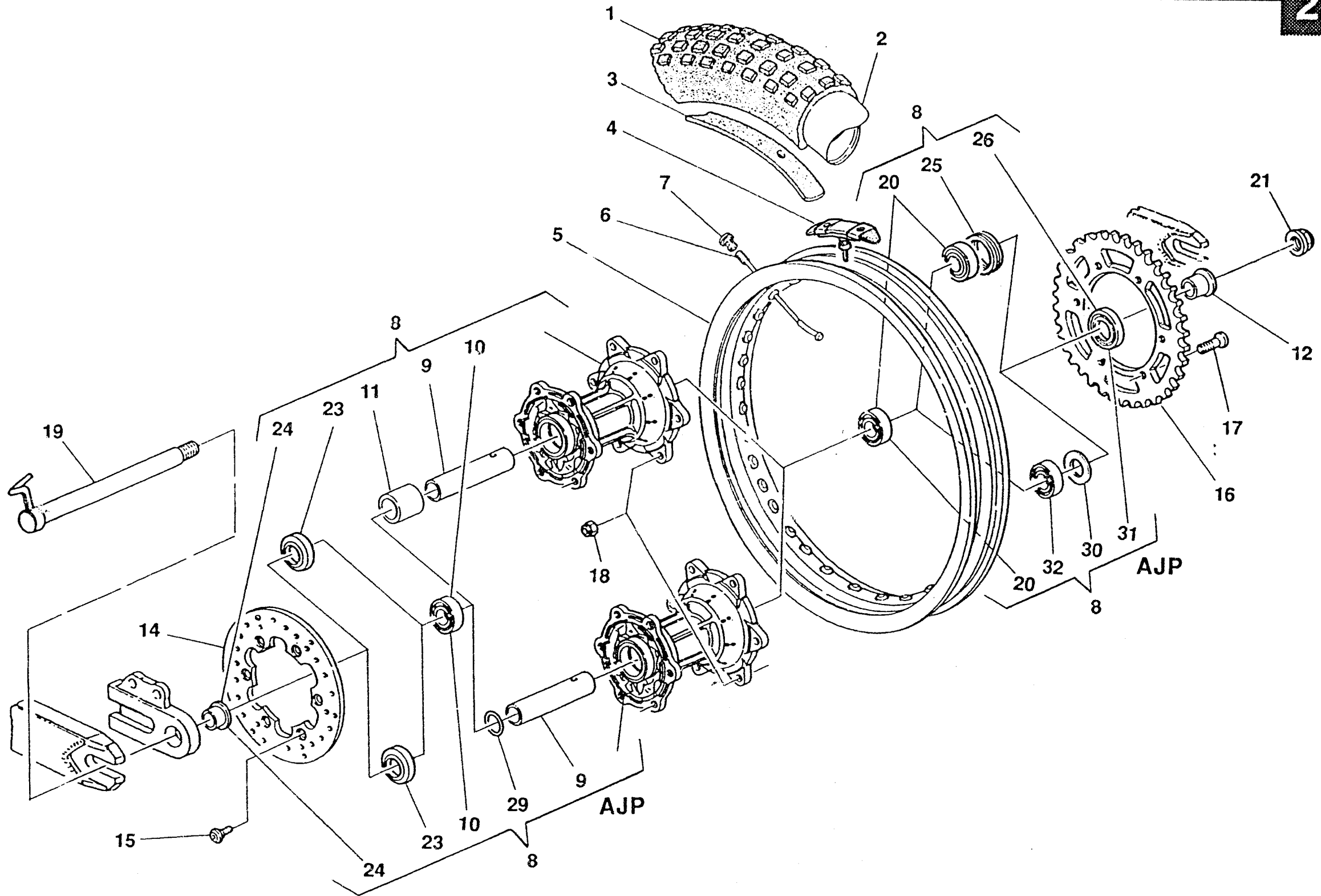



TE - TE U.S.A.
410 - 610 / 99
TC 610 / 99

TAVOLA
DRAWING
TABLE
BILD
TABLA

23

RUOTA POSTERIORE - REAR WHEEL
ROUE ARRIERE - HINTERRAD
RUEDA TRASERA

Note Notes Notas	Pos. No. Index Pos.	N. Cod. Code No. Nr. Code Code Nr. N. Cod.	Q.tà Q.ty Q.té M.ge C.zd	DENOMINAZIONE	NAME	DESIGNATION	BESCHREIBUNG	DENOMINACION	Validità Valdity Valdité Gültig Validez
AC	16	8F00 91498	1	Corona Z = 52 (SUPER SPROX)	Ring gear Z = 52 (SUPER SPROX)	Couronne Z = 52 (SUPER SPROX)	Kranz Z = 52 (SUPER SPROX)	Corona Z = 52 (SUPER SPROX)	
R	16	8000 60062	1	Corona Z = 48	Ring gear	Couronne	Kranz	Corona	
R	16	8000 60063	1	Corona Z = 49	Ring gear	Couronne	Kranz	Corona	
R	16	8000 50064	1	Corona Z = 50	Ring gear	Couronne	Kranz	Corona	
R	16	8000 60065	1	Corona Z = 51	Ring gear	Couronne	Kranz	Corona	
R	16	8000 60066	1	Corona Z = 52	Ring gear	Couronne	Kranz	Corona	
RA	16	8B00 91498	1	Corona Z = 48 (SUPER SPROX)	Ring gear Z = 48 (SUPER SPROX)	Couronne Z = 48 (SUPER SPROX)	Kranz Z = 48 (SUPER SPROX)	Corona Z = 48 (SUPER SPROX)	
RA	16	8C00 91498	1	Corona Z = 49 (SUPER SPROX)	Ring gear Z = 49 (SUPER SPROX)	Couronne Z = 49 (SUPER SPROX)	Kranz Z = 49 (SUPER SPROX)	Corona Z = 49 (SUPER SPROX)	
RA	16	8D00 91498	1	Corona Z = 50 (SUPER SPROX)	Ring gear Z = 50 (SUPER SPROX)	Couronne Z = 50 (SUPER SPROX)	Kranz Z = 50 (SUPER SPROX)	Corona Z = 50 (SUPER SPROX)	
RA	16	8E00 91498	1	Corona Z = 51 (SUPER SPROX)	Ring gear Z = 51 (SUPER SPROX)	Couronne Z = 51 (SUPER SPROX)	Kranz Z = 51 (SUPER SPROX)	Corona Z = 51 (SUPER SPROX)	
RA	16	8F00 91498	1	Corona Z = 52 (SUPER SPROX)	Ring gear Z = 52 (SUPER SPROX)	Couronne Z = 52 (SUPER SPROX)	Kranz Z = 52 (SUPER SPROX)	Corona Z = 52 (SUPER SPROX)	
	17	8000 40796	6	Vite	Screw	Vis	Schraube	Tornillo	
	18	8000 43928	6	Dado	Nut	Ecrou	Mutter	Tuerca	
AY	19	8C00 72621	1	Perno	Pin	Pivot	Bolzen	Perno	
A	19	8A00 72621	1	Perno	Pin	Pivot	Bolzen	Perno	
	20	8000 39651	2	Cuscinetto	Bearing	Roulement	Kugellager	Cojinete	
	20	8000 39651	1	Cuscinetto (AJP)	Bearing (AJP)	Roulement (AJP)	Kugellager (AJP)	Cojinete (AJP)	
	21	8000 64301	1	Dado	Nut	Ecrou	Mutter	Tuerca	
	23	8000 69163	1	Anello di tenuta	Seal ring	Bague d'étanchéité	Dichtungsring	Anillo de retención	
	23	8000 89573	1	Anello di tenuta (AJP)	Seal ring (AJP)	Bague d'étanchéité (AJP)	Dichtungsring (AJP)	Anillo de retención (AJP)	
	24	8000 69164	1	Distanziale	Spacer	Entretoise	Distanzstück	Separador	
	25	8000 64863	1	Ghiera	Ring nut	Embout	Nutmutter	Virola	
	26	8000 36357	1	Anello di tenuta	Seal ring	Bague d'étanchéité	Dichtungsring	Anillo de retención	
	29	8000 30052	1	Anello OR (AJP)	O - Ring (AJP)	Anneau OR (AJP)	O - Ring (AJP)	Anillo OR (AJP)	
	30	66N0 21272	1	Anello elastico (AJP)	Split ring (AJP)	Anneau ressort (AJP)	Sprengring (AJP)	Anillo elástico (AJP)	
	31	8000 89572	1	Anello di tenuta (AJP)	Seal ring (AJP)	Bague de retenue (AJP)	Dichtring (AJP)	Anillo de retención (AJP)	
	32	8000 15659	1	Cuscinetto stagno (AJP)	Bearing (AJP)	Roulement (AJP)	Lager (AJP)	Cojinete (AJP)	

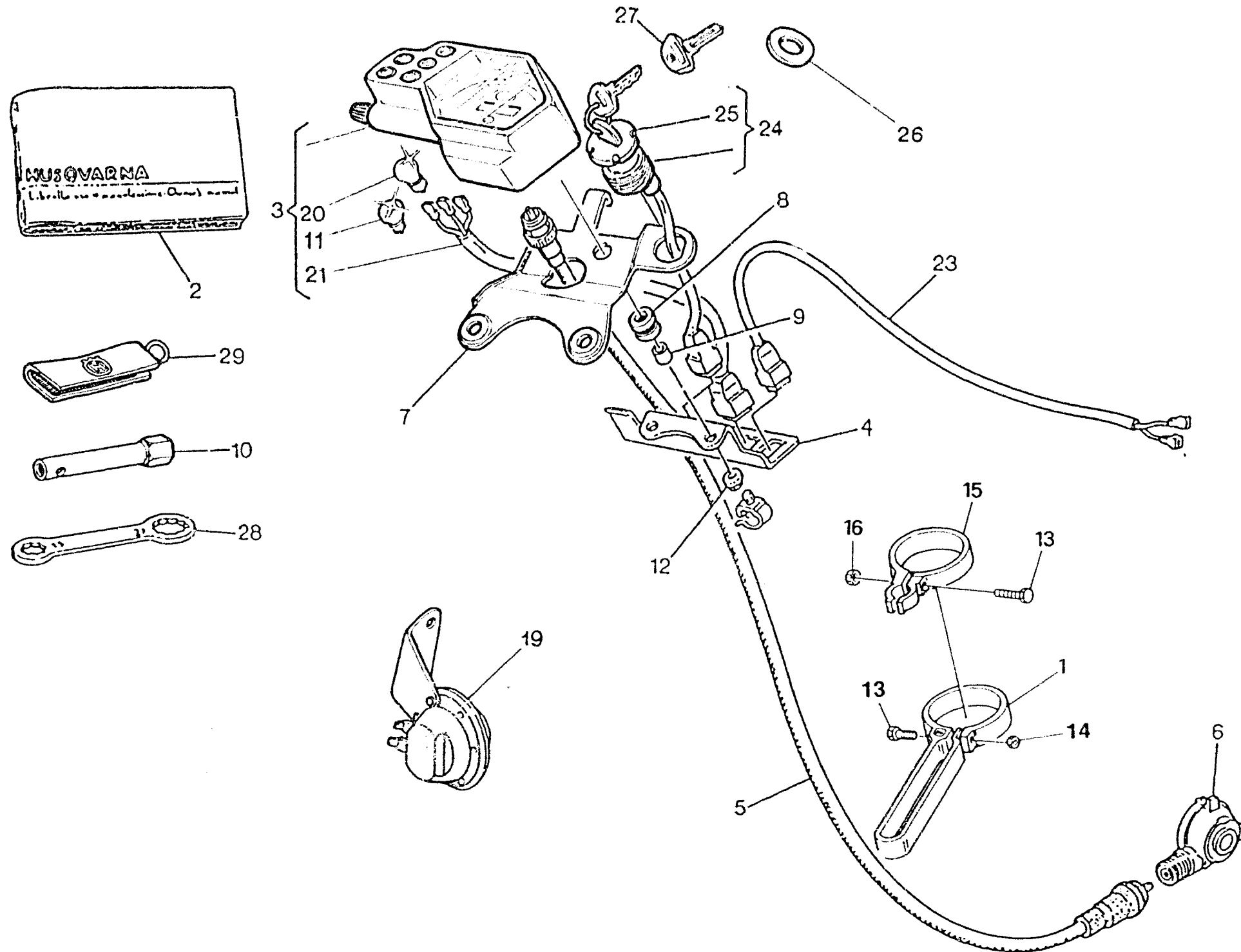



TE - TE U.S.A.
410 - 610 / 99
TC 610 / 99

TAVOLA
DRAWING
TABLE
BILD
TABLA

24

CONTACHILOMETRI, LIBRETTO USO MANUTENZIONE, AVV. ACUSTICO - SPEEDOMETER, OWNER'S MANUAL, HORN
COMPTE-KILOMETRES, EMPLOI D'ENTRETIEN, SIGNAL ACOUSTIQUE - TACHOMETER, BETRIEBSANLEITUNG,
BREMSSCHEIBESCHUTZ, HUPE - CUENTA-KILOMETROS, FOLLETO DE INSTRUCCIONES, AVISADOR ACUSTICO

Note Notes Marku Notas	Pos. No. N. index Pos.	N. Cod. Code No. Nr. Code Code Nr N. Cod.	Q.tà Q.ty Q.te M.ge C.ad	DENOMINAZIONE	NAME	DESIGNATION	BESHREIBUNG	DENOMINACION	Valdri Valdri Valdri Gültig Váldez
XY	1	8AA0 65340	1	Fascetta	Clamp	Collier	Schelle	Banda	
WC	2	8000 90075	1	Libretto uso e manutenzione	Owner's manual	Emploi d'entretien	Betriebsanleitung	Manual de uso y mantenimiento	
U	2	8000 90597	1	Libretto uso e manutenzione	Owner's service and tuning manual	Emploi d'entretien	Betriebsanleitung	Manual de uso y mantenimiento	
XY	3	8000 87849	1	Ass. contachilometri	Speedometer assy	Compteur-km. compl.	Tachometer kpl.	Cuenta-kilómetros compl.	
XY	4	8000 69428	1	Piastra	Plate	Plaque	Platte	Placa	
XY	5	8C00 71759	1	Trasmissione contachilometri	Speedometer cable	Câble compteur - km	Tachokabel	Cable cuenta-kilómetros	
XY	6	8000 77827	1	Rinvio contachilometri	Odometer transm.	Renvoi compte-km.	Vorgelege Kilometerzähler	Reenvío cuenta-kilómetros	
XY	7	8000 87847	1	Piastra	Plate	Plaque	Platte	Placa	
XY	8	8000 62651	2	Antivibrante	Silent-block	Antivibration	Schwingungsdämpfer	Anti-vibrador	
XY	9	8000 25053	2	Distanziale	Spacer	Entretoise	Distanzstück	Separador	
	10	1619 69801	1	Chiave candela	Spark plug wrench	Clé bougie	Zündkerzeschlüssel	Llave bujía	
XY	11	8000 60033	2	Lampadina 12V/2W	Lamp	Lampe	Lampe	Lamparilla	
XY	12	8000 61313	2	Dado	Nut	Ecrou	Mutter	Tuerca	
XY	13	8B00 66525	2	Vite	Screw	Vis	Schraube	Tomillo	
XY	14	61N1 15192	1	Dado	Nut	Ecrou	Mutter	Tuerca	
XY	15	80A0 70581	1	Fascetta	Clamp	Collier	Schelle	Banda	
XY	16	8000 56443	1	Dado	Nut	Ecrou	Mutter	Tuerca	
XY	19	8000 90107	1	Avvisatore acustico	Horn	Signal acoustique	Hupe	Avisador acústico	
XY	20	8000 20602	5	Lampadina 12V/1,2W	Lamp	Lampe	Lampe	Lamparilla	
XY	21	8000 87088	1	Cavi	Cable	Cable	Kabel	Cable	
XY	23	8000 75477	1	Cavi	Cable	Cable	Kabel	Cable	
XY	24	8000 74259	1	Interr. accensione completo	Ignition switch assy	Interrupteur pour allum. comp.	Schalter, Kpl.	Interruptor encendido compl.	
XY	25	8000 74258	1	Ghiera	Ring nut	Embout	Nutmutter	Viola	
XY	26	8000 50569	1	Distanziale	Spacer	Entretoise	Distanzstück	Separador	
XY	27	8000 38210	1	Chiave grezza	Raw key	Cléf primitive	Schlüssel	Llave greggia	
	28	8000 66802	1	Chiave poligonale	Box wrench	Clé polygonale	Sechskantschlüssel	Llave poligonal	
XR	29	8000 72037	1	Porta chiavi (in dotazione)	Key-ring (to issue)	Porte-clefs (en necessaire)	Schlüsselring (ausrüstungsteile)	Llavero (en dotacion)	

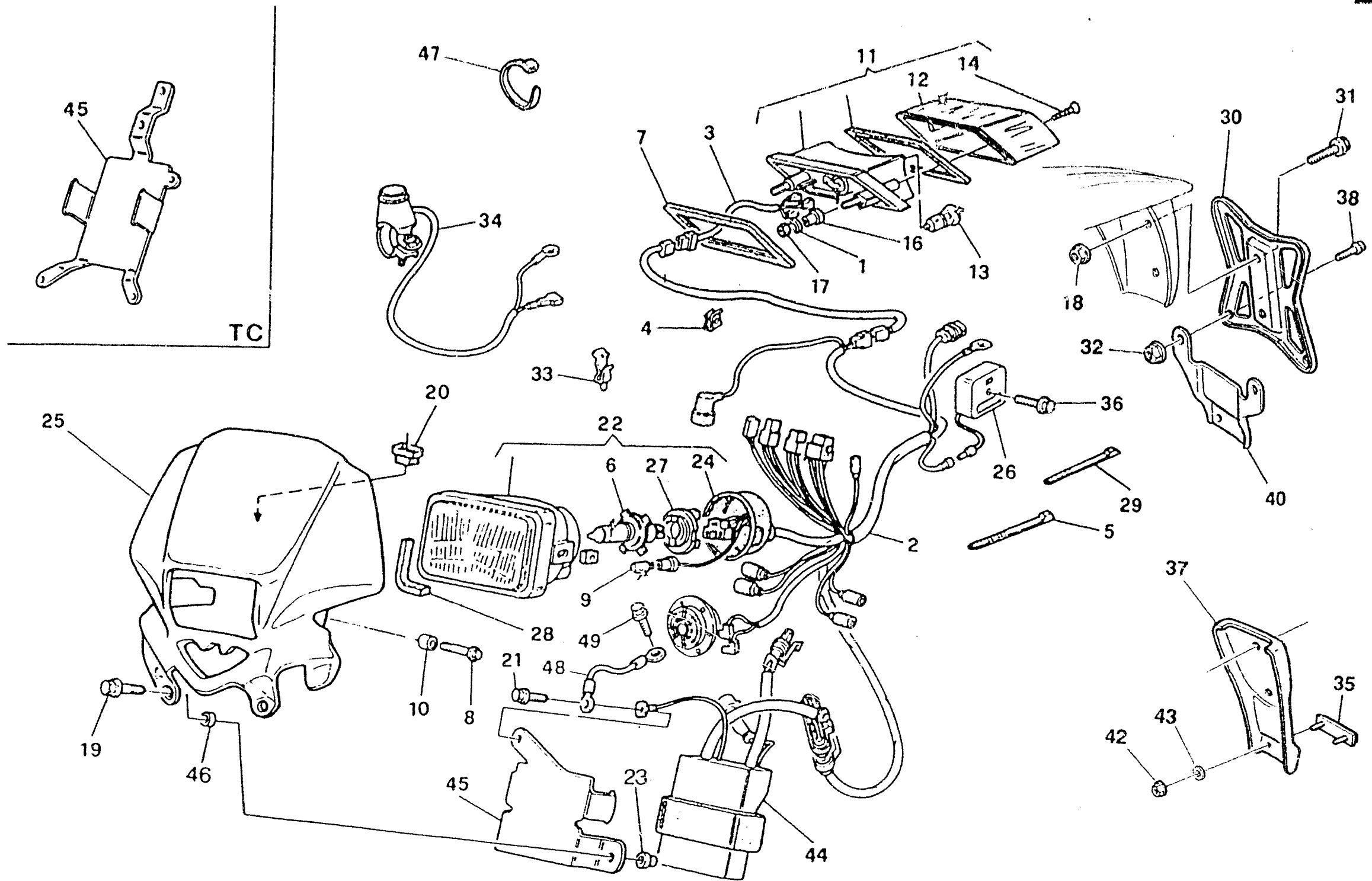



TE - TE U.S.A.
410 - 610 / 99
TC 610 / 99

TAVOLA
DRAWING
TABLE
BILD
TABLA

25

IMPIANTO ELETTRICO, PORTATARGA, PORTANUMERO - ELECTRIC SYS., PLATE HOLDER, NUMBER HOLDER
INSTALLATION ELECT., PORTE-BALAI, PORTE-NOMBRE - ELEK. ANLAGE, SCHILDTRAEGER, NUMMERTRAGER
INSTALAC. ELECT., PORTA-MATRICULA, PORTA NUMERO

Note Notes Notas	Pos. No. Index Pos.	N. Cod. Code No. Nr. Code Code Nr N. Cod.	Q.1A Q.1y Q.1e M. ge C. ad	DENOMINAZIONE	NAME	DESIGNATION	BESHREIBUNG	DENOMINACION	Validità Validité Gültig Validez
XY	1	62N1 15549	2	Rosetta piana	Washer	Rondelle	Scheibe	Arandela	
W	2	8000 79758	1	Gruppo principale cavi	Cable assy	Cables compl.	Kabel Kpl.	Grupo principal cables	
CU	2	8000 80142	1	Gruppo principale cavi	Cable assy	Cables compl.	Kabel Kpl.	Grupo principal cables	
XY	3	8000 70277	1	Cavo posteriore	Cable	Cable	Kabel	Cable	
XY	4	8000 72494	1	Passacavo	Fairlead	Passe-câble	Kabelführung	Prensa-cable	
	5	8000 34002	5	Fascetta	Clamp	Collier	Schelle	Banda	
XY	6	8000 42946	1	Lampada	Lamp	Lampe	Lampe	Lamparilla	
XY	7	8000 66479	1	Guarnizione	Gasket	Garniture	Dichtung	Junta	
XY	8	8000 62728	2	Vite	Screw	Vis	Schraube	Tornillo	
XY	9	8000 36727	1	Lampada	Lamp	Lampe	Lampe	Lamparilla	
XY	10	8B00 69429	2	Distanziale	Spacer	Entretoise	Distanzstück	Separador	
XY	11	8000 65555	1	Fanale posteriore completo	Tail light	Feux arrière	Hinterleuchte	Faro trasero	
XY	12	8000 66480	1	Lente	Lens	Loupe	Linse	Lente	
XY	13	8000 18246	1	Lampada	Lamp	Lampe	Lampe	Lamparilla	
XY	14	8000 66482	2	Vite	Screw	Vis	Schraube	Tornillo	
XY	16	8000 62416	2	Distanziale	Spacer	Entretoise	Distanzstück	Separador	
XY	17	8000 44240	2	Dado	Nut	Ecrou	Mutter	Tuerca	
XY	18	8000 44240	2	Dado	Nut	Ecrou	Mutter	Tuerca	
XY	19	8000 62730	2	Vite	Screw	Vis	Schraube	Tornillo	
XY	20	8000 50808	2	Gommino	Rubber pad	Pièce caoutchouc	Gummistück	Junta de goma	
	21	8000 62725	1	Vite	Screw	Vis	Schraube	Tornillo	
XYA	22	8000 70280	1	Gruppo ottico completo CEV	Optical group CEV	Groupe optique CEV	Optische Gruppe CEV	Grupo óptico CEV	
XYA	22	8000 87562	1	Gruppo ottico completo ECIE	Optical group ECIE	Groupe optique ECIE	Optische Gruppe ECIE	Grupo óptico ECIE	
	22	8000 90197	1	Gruppo ottico compl. (GB - AUS)	Optical group (GB - AUS)	Groupe optique (GB - AUS)	Optische Gruppe (GB - AUS)	Grupo óptico (GB - AUS)	
XY	23	8C00 70034	2	Distanziale	Spacer	Entretoise	Distanzstück	Separador	
XY	24	8000 70282	1	Cuffia in gomma	Boot	Poussière	Gummihaube	Gorro de protección en goma	
XY	25	80C0 87060	1	Cupolino	Fairing	Carenage	Verkleidung	Cúpula	
Y	26	8000 79571	1	Regolatore di tensione	Voltage rectifier	Régulateur de tension	Spannungsregler	Regulador de tensión	
XY	27	8000 42926	1	Portalampada	Lamp holder	Douille	Lampenfassung	Porta-lamparilla	
XY	28	8000 88139	1	Guarnizione	Gasket	Garniture	Dichtung	Junta	
Y	29	8000 56444	10	Fascetta	Clamp	Collier	Schelle	Banda	
XY	30	8000 62700	1	Staffa	Bracket	Etrier	Buegel	Brida	

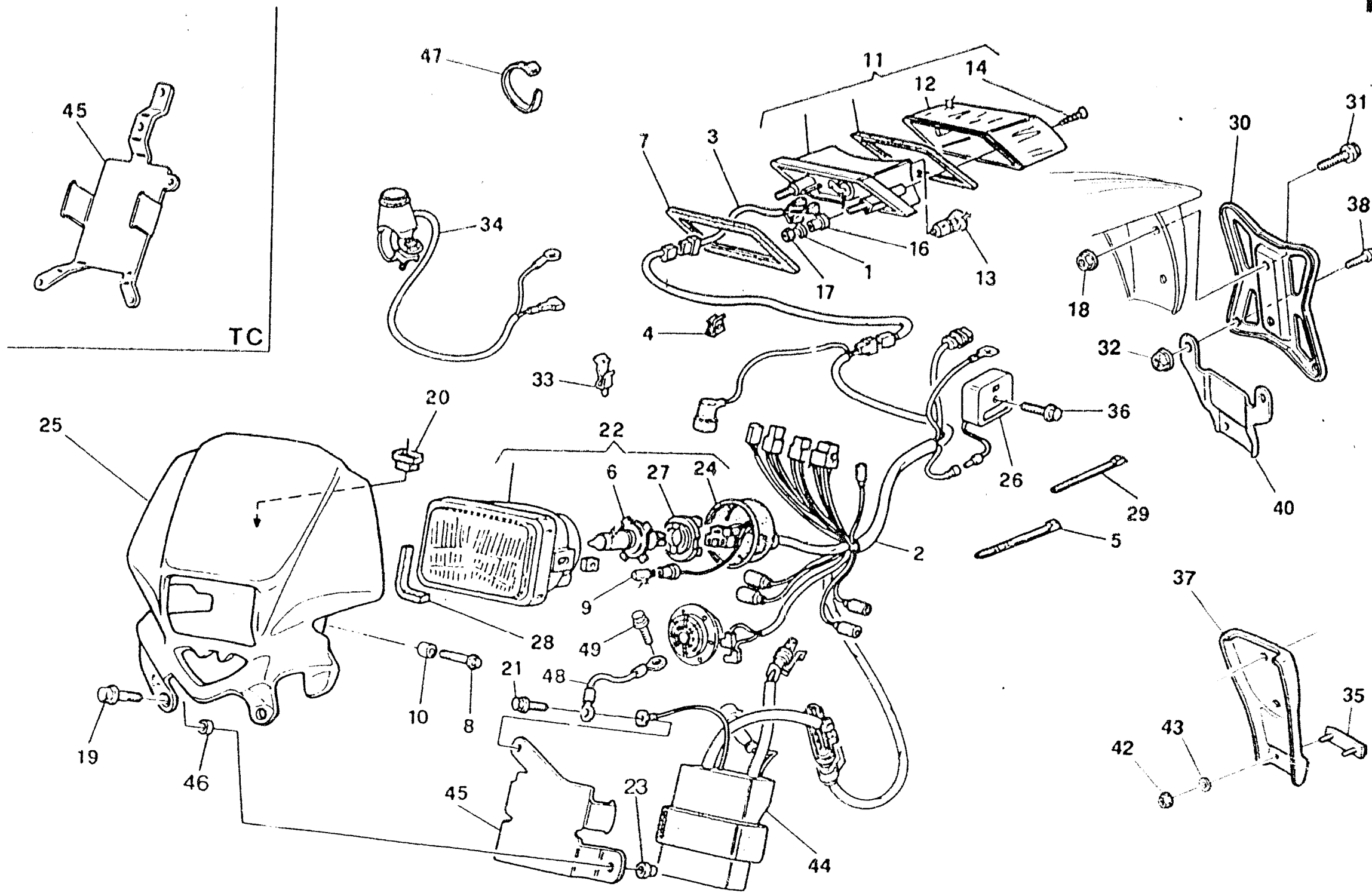



TE - TE U.S.A.
410 - 610 / 99
TC 610 / 99

TAVOLA
DRAWING
TABLE
BILD
TABLA

25

IMPIANTO ELETTRICO, PORTATARGA, PORTANUMERO - ELECTRIC SYS., PLATE HOLDER, NUMBER HOLDER
INSTALLATION ELECT., PORTE-BALAI, PORTE-NOMBRE - ELEK. ANLAGE, SCHILDTRAEGER, NUMMERTRAGER
INSTALAC. ELECT., PORTA-MATRICULA, PORTA NUMERO

Note Notes Notas	Poe. No. N. Index Pos.	N. Cod. Code No. Nr. Code Code Nr N. Cod.	Q.tà Q.ty Q.té M.ge C.ad	DENOMINAZIONE	NAME	DESIGNATION	BESCHREIBUNG	DENOMINACION	Valdri Vádrý Valdré Gullig Vardéz
XY	31	8000 62727	2	Vite	Screw	Vis	Schraube	Tomillo	
XY	32	8000 40718	2	Dado	Nut	Ecrou	Mutter	Tuerca	
XY	33	8000 58207	1	Passacavo	Fairlead	Passe-câble	Kabelführung	Prensa-cable	
CU	34	8000 65391	1	Pulsante «Engine Stop»	«Engine Stop» button	Bouton «Engine Stop»	Drucktaste «Engine Stop»	Pulsador «Engine Stop»	
XY	35	8000 73834	1	Catadiottro	Reflector	Catadioptrique	Rückstrahler	Catafaros	
Y	36	8000 62730	1	Vite	Screw	Vis	Schraube	Tomillo	
XY	37	8000 89969	1	Paraspruzzi (D - CH - A)	Rear end (D - CH - A)	Terminal (D - CH - A)	Hinterkiff (D - CH - A)	Para rociada (D - CH - A)	
XY	38	8A00 67997	2	Vite	Screw	Vis	Schraube	Tomillo	
XY	40	8000 87696	1	Piastra	Plate	Plaque	Platte	Placa	
XY	42	8000 40717	2	Dado	Nut	Ecrou	Mutter	Tuerca	
XY	43	62N1 15547	2	Rosetta	Washer	Rondelle	Scheibe	Arandela	
	44	8000 87550	1	Centralina elettronica	Electronic device	Dispositif électronique	Zündelektronik	Centralita electrónica	
W	45	8A00 79766	1	Piastra	Plate	Plaque	Platte	Placa	
CU	45	8000 79767	1	Piastra	Plate	Plaque	Platte	Placa	
	46	8B00 69429	2	Bussola	Bushing	Douille	Buchse	Manguito	
CU	47	8000 71578	2	Fascetta	Clamp	Collier	Schelle	Banda	
	48	8000 84139	1	Cavetto di massa	Cable	Cable	Kabel	Cable	
CU	49	60N1 01076	1	Vite	Screw	Vis	Schraube	Tomillo	

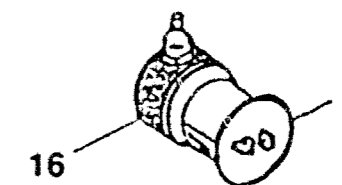
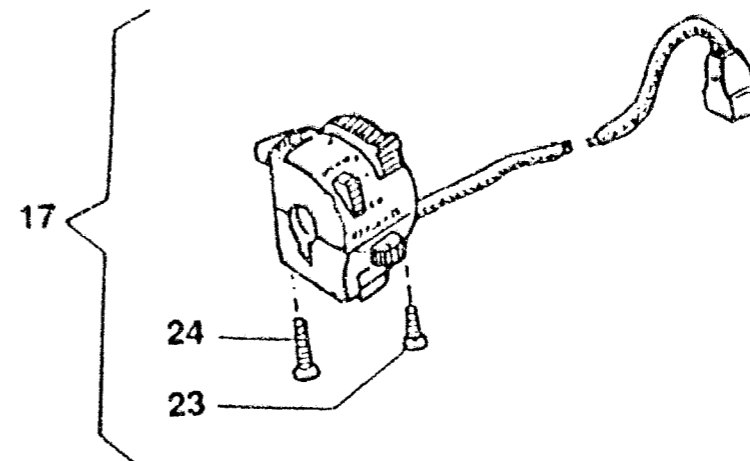
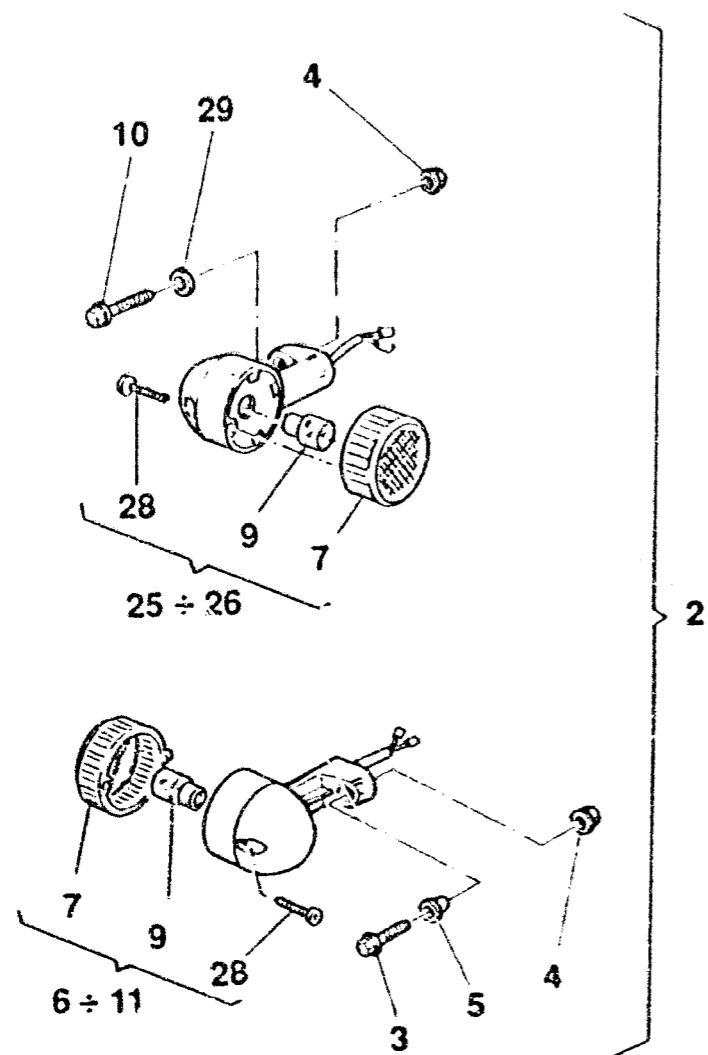



TE 410 / 99
TE 610 / 99

TAVOLA
DRAWING
TABLE
BILD
TABLA

26

FRECCE - BLINKER
CLIGNOTANT - BLINKER
INTERMITENTE

Note Notes Mark Notas	Pos. No. N. Index Pos.	N. Cod. Code No. Nr. Code Code Nr. N. Cod.	Q. Ia Q. Iy Q. Ie M. pt C. ad	DENOMINAZIONE	NAME	DE SIGNATION	BESCHREIBUNG	DE NOMINACION	Variante Variant Variant Variant
D	1	8000 57511	2	Intermittenza	Flash device	Intermittence	Blinkgeber	Intermitencia	
D	2	8000 88338	1	Kit indicatori di direzione	Blinker kit	Gr. clignotant	Blinker Gruppe	Kit intermitente	
D	4	8000 44240	4	Dado	Nut	Ecrou	Mutter	Tuerca	
D	5	8000 45495	2	Bussola	Bush	Douille	Buchse	Manguito	
D	6	8000 88336	1	Indicatore anteriore DX	Blinker R	Clignotant D	Blinker R	Intermitente D	
D	7	8000 73591	4	Lente	Lens	Loupe	Linse	Lente	
D	9	8000 36726	4	Lampada 12V - 10W	Lamp	Lampe	Lampe	Lamparilla	
D	10	8000 62728	4	Vite	Screw	Vis	Schraube	Tornillo	
D	11	8000 88337	1	Indicatore anteriore SX	Blinker L	Clignotant G	Blinker L	Intermitente I	
D	16	8000 37599	1	Supporto elastico	Support	Support	Halterung	Soporte	
	17	8000 89919	1	Commutatore compl. (CEV)	Switch compl. (CEV)	Commutateur compl. (CEV)	Kombischalter kpl. (CEV)	Commutador compl. (CEV)	
	17	8000 89920	1	Commutatore compl. (ECIE)	Switch compl. (ECIE)	Commutateur compl. (ECIE)	Kombischalter kpl. (ECIE)	Commutador compl. (ECIE)	
D	25	8000 88334	1	Indicatore posteriore DX	Blinker R	Clignotant D	Blinker R	Intermitente D	
D	26	8000 88335	1	Indicatore posteriore SX	Blinker L	Clignotant G	Blinker L	Intermitente I	
	27	8000 71578	2	Fascetta	Clamp	Collier	Schelle	Banda	
D	28	8000 73592	4	Vite	Screw	Vis	Schraube	Tornillo	
D	29	8000 56359	2	Rosetta	Washer	Rondelle	Scheibe	Roseta	

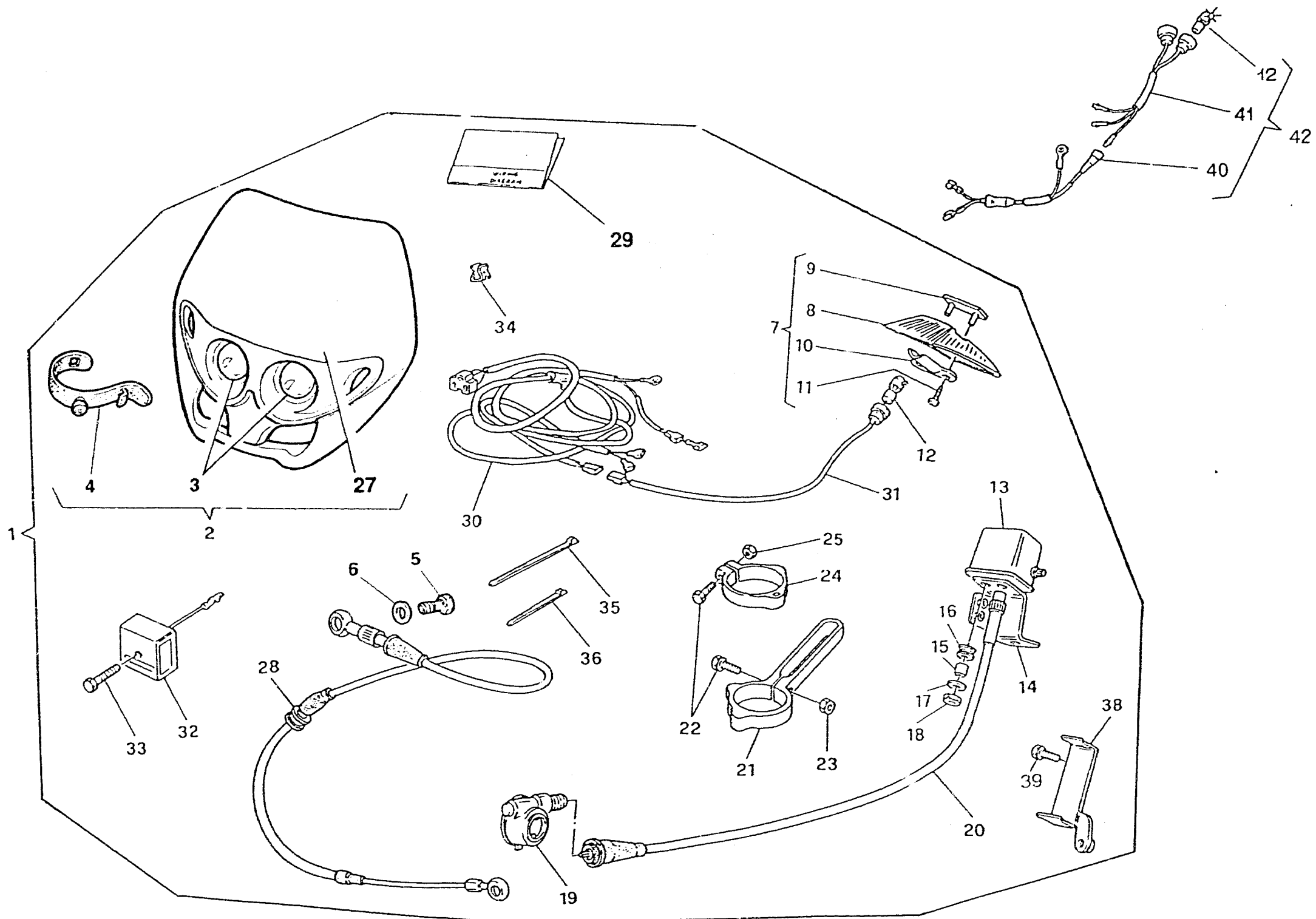



TE U.S.A.
410 - 610 / 99

TAVOLA
DRAWING
TABLE
BILD
TABLA

27

KIT TRASFORMAZIONE ENDURO - ENDURO TRANSFORMATION KIT
GROUPE TRANSFORMATION ENDURO - ENDURO GRUPE
KIT TRANSFORMACION ENDURO

Note Notes Marka Notas	Pos. No. Index Pos.	N. Cod. Code No. Nr. Code Code Nr N. Cod.	Q.tà Q.ty Q.té M.ge C.ad	DENOMINAZIONE	NAME	DESIGNATION	BESHREIBUNG	DENOMINACION	Validità Validité Gültig Validez
	1	8000 90600	1	Kit enduro	Kit enduro	Groupe enduro	Gruppe Enduro	Kit enduro	
	2	8000 88538	1	Gruppo ottico completo	Optical group	Groupe optique	Optische Gruppe	Grupo óptico	
	3	8000 88603	1	Cupolino	Fairing	Carenage	Verkleidung	Cúpuia	
	4	8000 88602	4	Elastico	Elastic	Elastique	Elastisch	Elástico	
	5	8000 57155	1	Vite	Screw	Vis	Schraube	Tomillo	
	6	8000 21480	1	Rosetta	Washer	Rondelle	Scheibe	Arandela	
	7	8000 71213	1	Fanale posteriore completo	Tail light group	Groupe feux arrière	Hinterleuchte Gruppe	Grupo faro trasero	
	8	8000 71214	1	Fanale posteriore	Tail light	Feux arrière	Hinterleuchte	Faro trasero	
	9	8000 71215	1	Fascetta	Clamp	Collier	Schelle	Banda	
	10	8000 71216	1	Protezione	Guard	Protection	Schutz	Protección	
	11	8000 71217	2	Vite	Screw	Vis	Schraube	Tomillo	
	12	8000 26694	2	Lampadina	Lamp	Lampe	Lampe	Lamparilla	
	13	1517 54001	1	Contamiglia	Odometer	Compte-mille	Tachometer	Cuentamiglias	
	14	8000 80262	1	Piastra	Plate	Plaque	Platte	Placa	
	15	8000 41863	2	Distanziale	Spacer	Entretoise	Distanzstück	Separador	
	16	8000 41862	2	Gommino	Rubber pad	Pièce caoutchouc	Gummistück	Junta de goma	
	17	62N1 15548	2	Rosetta	Washer	Rondelle	Scheibe	Arandela	
	18	61N1 15191	2	Dado	Nut	Ecrou	Mutter	Tuerca	
	19	8000 77827	1	Rinvio contachilometri	Odometer transm.	Renvoi compte-km.	Vorgelege Kilometerzähler	Reenvío cuenta-kilómetros	
	20	8800 71759	1	Trasmissione contachilometri	Odometer cable	Câble compteur - km	Tachokabel	Cable cuenta-kilómetros	
	21	8AA0 65340	1	Fascetta	Clamp	Collier	Schelle	Banda	
	22	8800 66525	2	Vite	Screw	Vis	Schraube	Tomillo	

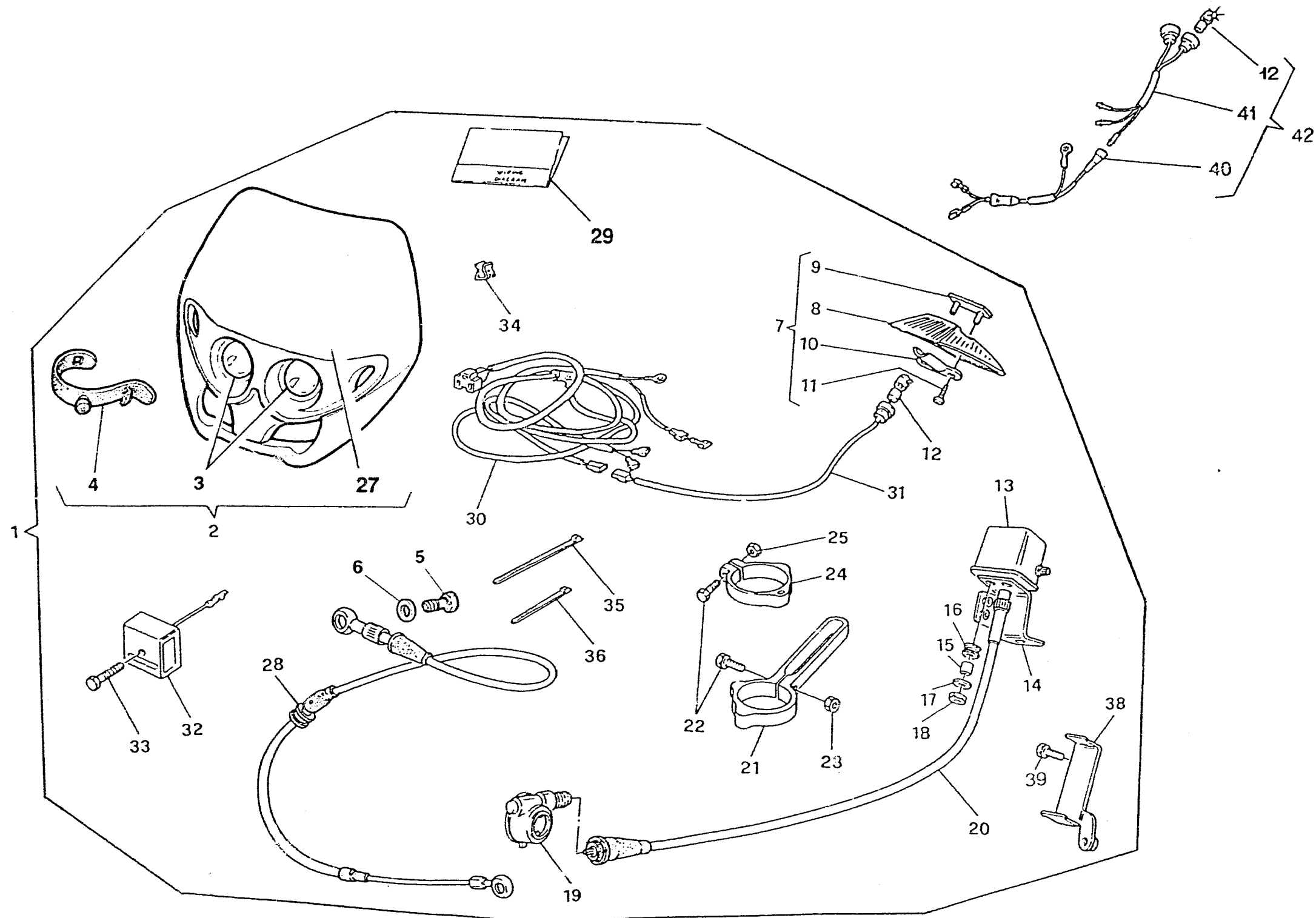



TE U.S.A.
410 - 610 / 99

TAVOLA
DRAWING
TABLE
BILD
TABLA

27

KIT TRASFORMAZIONE ENDURO - ENDURO TRANSFORMATION KIT
GROUPE TRANSFORMATION ENDURO - ENDURO GRUPPE
KIT TRANSFORMACIÒN ENDURO

Note Notes Marka Notas	Pos. No. N. Index Pos.	N. Cod. Code No. Nr. Code Code Nr N. Cod.	Q.tà Q.ty Q.te M.ge C.od	DENOMINAZIONE	NAME	DESIGNATION	BESHREIBUNG	DENOMINACION	Validità Validty Validké Gültig Validez
	34	8000 71315	1	Guidacavo	Cable guide	Guide câble	Kabelführung	Guía-cable	
	35	8000 56444	3	Fascetta	Clamp	Collier	Schelle	Banda	
	36	8000 34002	2	Fascetta	Clamp	Collier	Schelle	Banda	
	38	8000 80261	1	Piastrina	Plate	Plaque	Platte	Placa	
	39	8000 67997	2	Vite	Screw	Vis	Schraube	Tornillo	
	40	8000 80004	1	Cablecavo	Front wiring	Cablecavo	Verd. Verkabelung	Cablecavo	



1

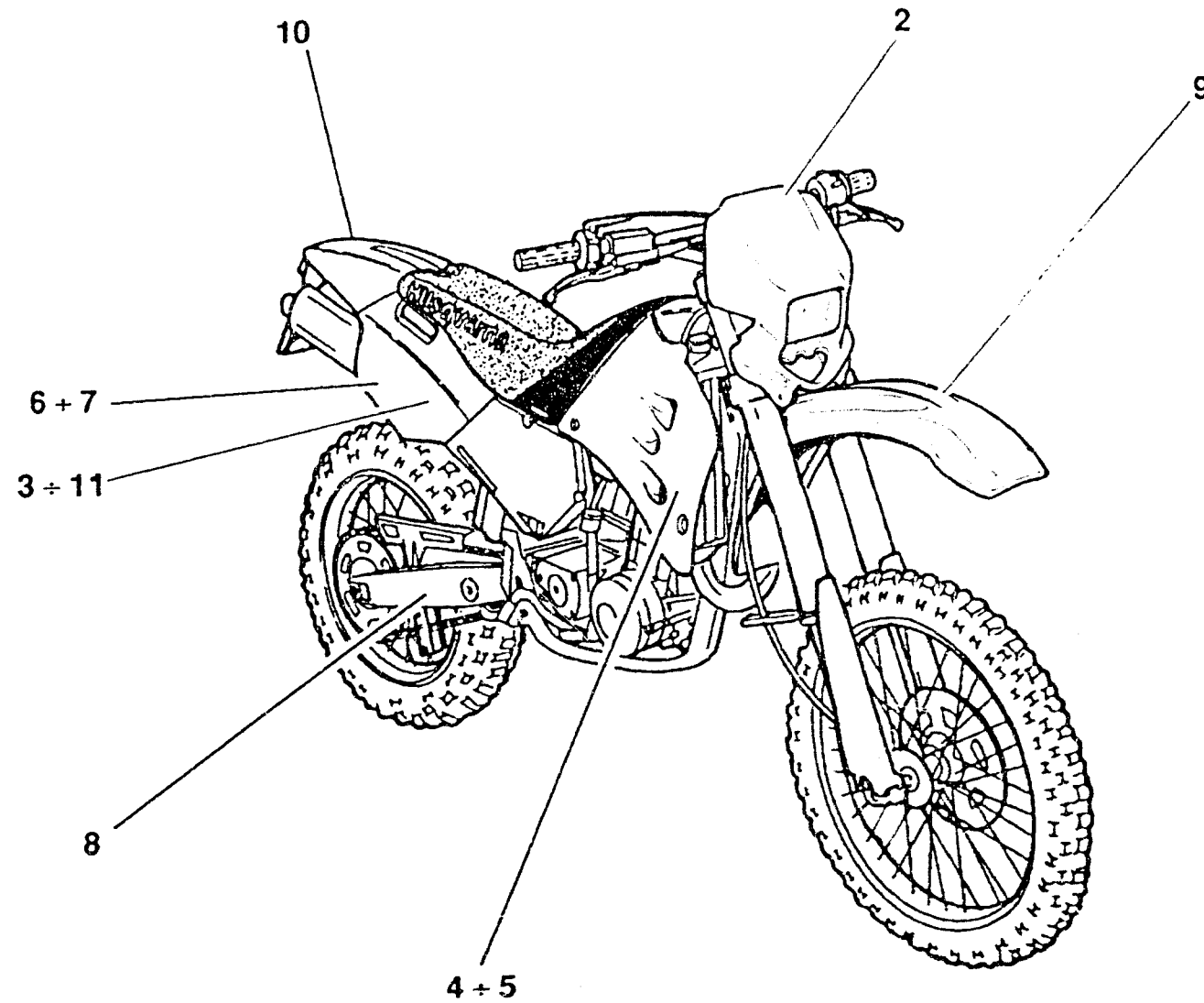



TE 410 / 99
TE 610 / 99

TAVOLA
DRAWING
TABLE
BILD
TABLA

28

DECALCOMANIE - TRANSFER
DACALCOMANIE - ABZIEHBILD
CALCOMANIA

(TE)

Note Notes Marka Notas	Pos. No. N. Index Pos.	N. Cod. Code No. Nr. Code Code Nr N. Cod.	Q.tà Q.ty Q.te M.ge C.ad	DENOMINAZIONE	NAME	DESIGNATION	BESHREIBUNG	DENOMINACION	Validità Validité Gültig Validez
	1	8000 90072	1	Kit adesivi (610)	Transfer kit (610)	Gr. décal. (610)	Hinterabziehbild Gruppe (610)	Kit adhesivo (610)	
	1	8000 90180	1	Kit adesivi (410)	Transfer kit (410)	Gr. décal. (410)	Hinterabziehbild Gruppe (410)	Kit adhesivo (410)	
	2	8000 87682	1	Decal per portafaro	Transfer	Decalcomania	Abziehbild	Calcomania	
	3	8000 88690	1	Decal nera Sx	L.H. transfer	Decalcomania G.	Abziehbild L.	Calcomania izq.	
	4	8000 91040	1	Decal per convogliatore Dx	R.H. transfer	Decalcomania D.	Abziehbild R.	Calcomania der.	
	5	8000 91041	1	Decal per convogliatore Sx	L.H. transfer	Decalcomania G.	Abziehbild L.	Calcomania izq.	
	6	8000 91042	1	Decal per fianchetto Dx	R.H. transfer	Decalcomania D.	Abziehbild R.	Calcomania der.	
	7	8000 91043	1	Decal per fianchetto Sx	L.H. transfer	Decalcomania G.	Abziehbild L.	Calcomania izq.	
	8	80K0 91044	2	Decal per forcellone (610)	Fork transfer (610)	Decalcomania (610)	Abziehbild (610)	Calcomania (610)	
	8	80G0 91044	2	Decal per forcellone (410)	Fork transfer (410)	Decalcomania (410)	Abziehbild (410)	Calcomania (410)	
	9	8000 91038	1	Decal HUSQVARNA	Transfer	Decalcomania	Abziehbild	Calcomania	
	10	8000 91039	1	Decal HUSQVARNA	Transfer	Decalcomania	Abziehbild	Calcomania	
	11	8000 88691	1	Decal nera Dx	R.H. transfer	Decalcomania D.	Abziehbild R.	Calcomania der.	

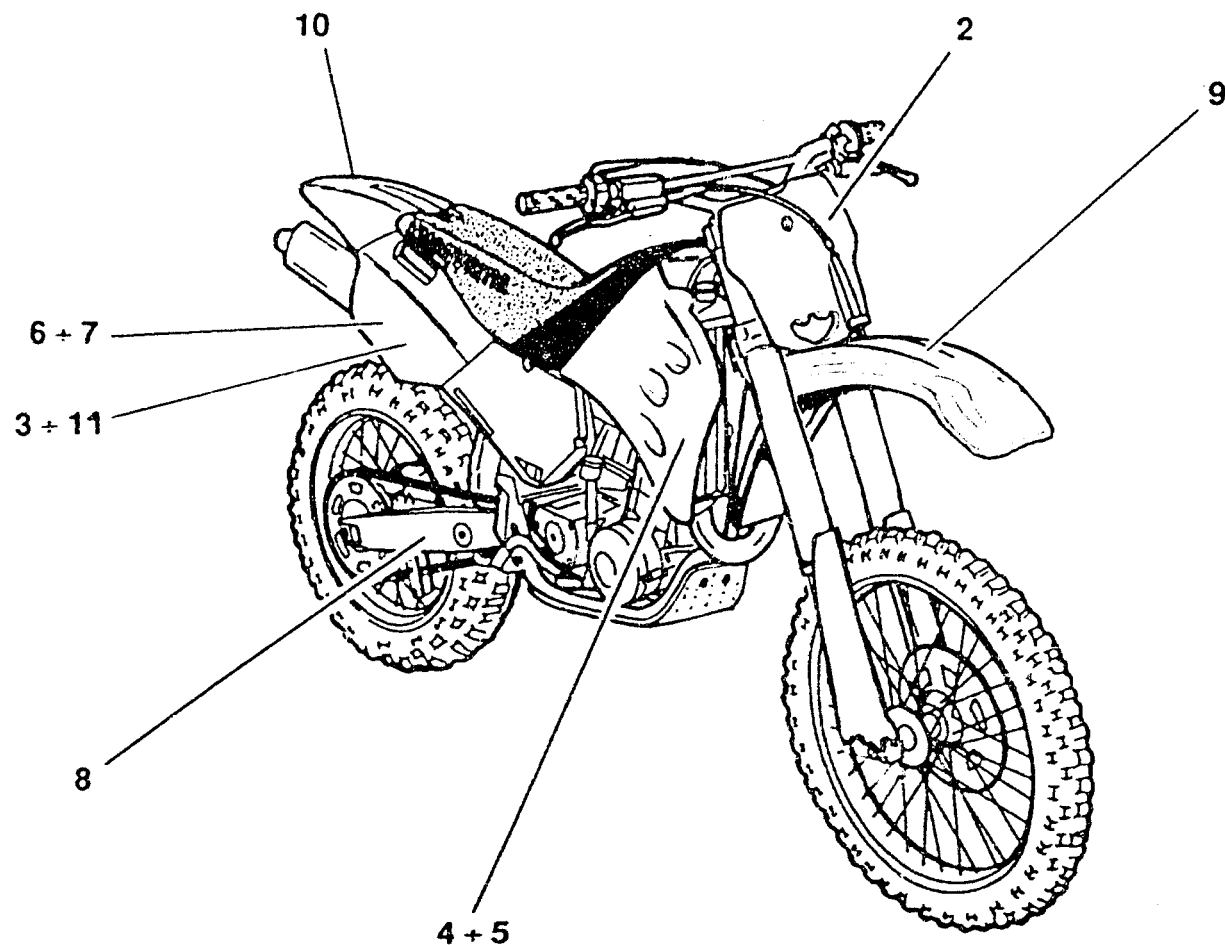
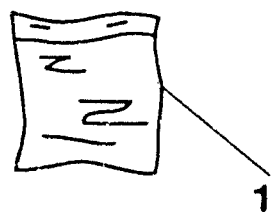



TE U.S.A.
410 - 610 / 99
TC 610 / 99

TAVOLA
DRAWING
TABLE
BILD
TABLA

29

DECALCOMANIE - TRANSFER
DACALCOMANIE - ABZIEHBILD
CALCOMANIA

Note Notes Notas	Pos. No. Index Pos.	N. Cod. Code No. Nr. Code Code Nr N. Cod.	Q.tà Q.ty Q.te M.ge C.ad	DENOMINAZIONE	NAME	DESIGNATION	BESHREIBUNG	DENOMINACION	Valore Válczy Válné Gótg Válczy
C	1	8000 90176	1	Kit adesivi	Transfer kit	Gr. décal.	Hinterabziehbild Gruppe	Kit adhesivo	
U	1	8000 90657	1	Kit adesivi (610)	Transfer kit (610)	Gr. décal. (610)	Hinterabziehbild Gruppe (610)	Kit adhesivo (610)	
U	1	8000 90596	1	Kit adesivi (410)	Transfer kit (410)	Gr. décal. (410)	Hinterabziehbild Gruppe (410)	Kit adhesivo (410)	
	2	8000 87933	1	Decal per portanumero	Transfer	Decalcomania	Abziehbild	Calcomania	
	3	8000 88690	1	Decal nera Sx	L.H. transfer	Decalcomania G.	Abziehbild L.	Calcomania izq.	
	4	8000 91040	1	Decal per convogliatore Dx	R.H. transfer	Decalcomania D.	Abziehbild R.	Calcomania der.	
	5	8000 91041	1	Decal per convogliatore Sx	L.H. transfer	Decalcomania G.	Abziehbild L.	Calcomania izq.	
	6	8000 91042	1	Decal per fianchetto Dx	R.H. transfer	Decalcomania D.	Abziehbild R.	Calcomania der.	
	7	8000 91043	1	Decal per fianchetto Sx	L.H. transfer	Decalcomania G.	Abziehbild L.	Calcomania izq.	
C	8	80L0 91044	2	Decal per forcellone	Fork transfer	Decalcomania	Abziehbild	Calcomania	
U	8	80K0 91044	2	Decal per forcellone (610)	Fork transfer (610)	Decalcomania (610)	Abziehbild (610)	Calcomania (610)	
U	8	80G0 91044	2	Decal per forcellone (410)	Fork transfer (410)	Decalcomania (410)	Abziehbild (410)	Calcomania (410)	
	9	8000 91038	1	Decal HUSQVARNA	Transfer	Decalcomania	Abziehbild	Calcomania	
	10	8000 91039	1	Decal HUSQVARNA	Transfer	Decalcomania	Abziehbild	Calcomania	
	11	8000 88691	1	Decal nera Dx	R.H. transfer	Decalcomania D.	Abziehbild R.	Calcomania der.	

DISEGNO DRAWING DESSIN ZEICHNUNG DIBUJO	TAVOLA DRAWING TABLE BILD TABLA	INDEX NO. POS. N. INDICE	DISEGNO DRAWING DESSIN ZEICHNUNG DIBUJO	TAVOLA DRAWING TABLE BILD TABLA	INDEX NO. POS. N. INDICE	DISEGNO DRAWING DESSIN ZEICHNUNG DIBUJO	TAVOLA DRAWING TABLE BILD TABLA	INDEX NO. POS. N. INDICE	DISEGNO DRAWING DESSIN ZEICHNUNG DIBUJO	TAVOLA DRAWING TABLE BILD TABLA	INDEX NO. POS. N. INDICE	DISEGNO DRAWING DESSIN ZEICHNUNG DIBUJO	TAVOLA DRAWING TABLE BILD TABLA	INDEX NO. POS. N. INDICE
0660 49053	6	42	1611 69901	8A	12	1615 08501	3	28	1616 02701	8A	48	61N1 15195	2	1
1511 24901	14	19	1611 70101	8	40	1615 09501	3	12	1616 36001	8A	49	61N1 15195	3	22
1511 33302	16	16	1611 70401	7	51	1615 09601	3	9	1616 36201	7	37	62N0 15682	6	43
1513 07001	12	2	1611 70601	7	62	1615 09801	4	3	1617 95501	2	37	62N1 15503	10	57
1513 41401	21	14	1611 70801	2	8	1615 10501	7	15	1619 69801	24	10	62N1 15503	10A	57
1513 71301	4	4	1611 70901	7	39	1615 11601	6	26	60N1 01048	10	55	62N1 15503	10B	71
1513 71401	8	47	1611 71501	8	44	1615 12301	3	24	60N1 01048	10A	55	62N1 15504	6	9
1513 72201	6	29	1611 71701	8	25	1615 12802	3	21	60N1 01048	10B	69	62N1 15504	12	35
1513 72601	6	3	1611 71701	8A	6	1615 13302	1	3	60N1 01076	25	49	62N1 15506	22	36
1513 72602	7	19	1611 74601	7	38	1615 14104	3	19	60N1 01081	8	17	62N1 15507	12	5
1513 74301	21	15	1611 81604	6	14	1615 15601	3	10	60N1 01081	8A	28	62N1 15519	5	28
1514 05704	20A	10	1611 83701	8	27	1615 23801	2	16	60N1 01219	13	62	62N1 15524	14	5
1514 05711	20	21	1612 35701	8	43	1615 26602	3	4	60N1 02487	9	8	62N1 15547	25	43
1514 10702	21	10	1612 36101	8	49	1615 27501	9	14	60N1 02504	7	75	62N1 15548	27	17
1514 13401	1	6	1612 36201	8	18	1615 28801	2	11	60N1 02510	2	34	62N1 15549	25	1
1515 50601	14	34	1612 36301	8	21	1615 29401	2	10	60N1 02510	6	15	62N1 15567	3	37
1515 59101	1	5	1612 36502	8	41	1615 29601	2	13	60N1 02510	7	50	62N1 15658	3	6
1515 80301	11	10	1612 38401	8	33	1615 30301	2	17	60N1 02511	18	26	62N1 15780	18	2
1516 21501	22A	12	1612 38401	8A	11	1615 31502	8	3	60N1 02511	21	3	62N4 15548	9	13
1517 54001	27	13	1612 38801	8	46	1615 31502	8A	44	60N1 02512	7	47	63N0 16374	8	58
1517 94701	1	1	1612 39001	8	23	1615 33201	2	4	60N1 02513	6	6	63N0 16374	8A	62
1517 94902	1	8	1612 41501	8	48	1615 34801	7	14	60N1 02513	7	54	64N1 20048	12	36
1519 65301	1	2	1612 41501	8A	9	1615 35101	2	-	60N1 02513	9	6	64N1 20068	12	8
1519 76703	19	16	1612 48001	8	20	1615 35501	4	11	60N1 02515	6	13	64N1 20068	18	7
1519 80501	1	4	1612 48101	8	19	1615 35801	2	3	60N1 02520	6	7	66N0 21205	7	31
1519 84701	1	13	1612 69901	8	39	1615 35902	2	18	60N1 02555	12	30	66N0 21208	7	70
1519 88201	1	12	1612 69901	8A	13	1615 35902	7	18	60N1 02557	2	35	66N0 21211	6	21
1610 77501	7	8	1612 84201	8	22	1615 36001	2	5	60N1 02866	7	16	66N0 21211	8	24
1610 77701	6	33	1612 84201	8A	52	1615 37001	4	12	60N1 02900	7	49	66N0 21211	8A	7
1610 77701	7	10	1614 58901	6	32	1615 38201	9	4	60N1 02927	3	33	66N0 21272	23	30
1611 08401	7	73	1614 59301	7	11	1615 38301	9	10	60N1 04134	20	7	69N4 29004	22A	9
1611 08501	7	57	1614 59301	7	7	1615 38801	8	30	60N1 07330	17	9	69N4 29005	22A	9
1611 21601	7	27	1614 72801	6	8	1615 38801	8A	22	60N1 07335	2	22	69N4 29005	23	7
1611 27101	7	28	1615 01403	6	27	1615 39001	10	44	60N1 07335	7	69	68N0 21509	8	15
1611 65003	7	13	1615 02301	2	14	1615 39001	10A	44	60N1 07350	20	15	68N0 21509	8A	4
1611 67702	7	35	1615 02501	2	12	1615 39101	7	32	61N1 15062	8	8	8000 01199	20	6
1611 68001	7	33	1615 03601	3	17	1615 39301	3	15	61N1 15062	8A	39	8000 01412	14	55
1611 68101	7	34	1615 04201	3	13	1615 40702	2	2	61N1 15062	18	27	8000 01412	16	19
1611 68401	7	24	1615 04301	3	8	1615 40802	3	23	61N1 15191	22	35	8000 01688	23	3
1611 68601	7	21	1615 04501	3	11	1616 01501	8A	47	61N1 15191	27	18	8000 02124	3	1
1611 69201	7	22	1615 04901	3	7	1616 01701	8A	27	61N1 15192	24	14	8000 04103	10	48
1611 69901	8	32	1615 08401	3	27	1616 02201	8A	2	61N1 15192	24	23	8000 04103	10A	48

Husqvarna

INDICE NUMERICO PROGRESSIVO / NUMERICAL INDEX / INDEX NUMERIQUE
NUMMERNVERZEICHNIS / ÍNDICE NUMÉRICO PROGRESIVO

TE - TE U.S.A. 410 - 610 / 99
TC 610 / 99

DISEGNO DRAWING DESIGN	TAVOLA DRAWING TABLE	INDEX NO. NO.	DISEGNO DRAWING DESIGN	TAVOLA DRAWING TABLE	INDEX NO. NO.	DISEGNO DRAWING DESIGN	TAVOLA DRAWING TABLE	INDEX NO. NO.	DISEGNO DRAWING DESIGN	TAVOLA DRAWING TABLE	INDEX NO. NO.	DISEGNO DRAWING DESIGN	TAVOLA DRAWING TABLE	INDEX NO. NO.
------------------------------	----------------------------	---------------------	------------------------------	----------------------------	---------------------	------------------------------	----------------------------	---------------------	------------------------------	----------------------------	---------------------	------------------------------	----------------------------	---------------------

DISEGNO DRAWING DESSIN ZEICHNUNG DIBUJO	TAVOLA DRAWING TABLE BILD TABLA	INDEX NO. POS. N. INDICE	DISEGNO DRAWING DESSIN ZEICHNUNG DIBUJO	TAVOLA DRAWING TABLE BILD TABLA	INDEX NO. POS. N. INDICE	DISEGNO DRAWING DESSIN ZEICHNUNG DIBUJO	TAVOLA DRAWING TABLE BILD TABLA	INDEX NO. POS. N. INDICE	DISEGNO DRAWING DESSIN ZEICHNUNG DIBUJO	TAVOLA DRAWING TABLE BILD TABLA	INDEX NO. POS. N. INDICE	DISEGNO DRAWING DESSIN ZEICHNUNG DIBUJO	TAVOLA DRAWING TABLE BILD TABLA	INDEX NO. POS. N. INDICE
8000 43928	14	30	8000 48916	17	19	8000 57155	18	35	8000 60196	23	2	8000 61355	13	53
8000 43928	14	56	8000 48918	17	35	8000 57155	22	14	8000 60233	13	59	8000 61362	20	9
8000 43928	21	13	8000 49036	22A	4	8000 57155	22	14	8000 60234	13	60	8000 61752	23	1
8000 43928	23	18	8000 49654	22	6	8000 57155	27	5	8000 60404	18	34	8000 62416	25	16
8000 44043	10	46	8000 50217	23	4	8000 57242	5	13	8000 60404	22	18	8000 62651	24	8
8000 44043	10A	46	8000 50322	3	47	8000 57413	10	45	8000 60463	8	45	8000 62675	14	45
8000 44240	11	11	8000 50569	24	26	8000 57413	10A	45	8000 60464	6	36	8000 62676	14	46
8000 44240	14	33	8000 50808	25	20	8000 57413	10B	27	8000 60470	8	55	8000 62700	25	30
8000 44240	14	53	8000 51957	22A	15	8000 57511	26	1	8000 60472	7	72	8000 62725	5	6
8000 44240	15	28	8000 53155	13	61	8000 58013	17	31	8000 60472	8	38	8000 62725	5	26
8000 44240	18	36	8000 53259	18	32	8000 58140	7	68	8000 60472	8A	14	8000 62725	5	27
8000 44240	19	4	8000 53259	22	24	8000 58207	25	33	8000 60473	8	37	8000 62725	5	35
8000 44240	19	13	8000 53339	2	38	8000 58929	23	5	8000 60473	8A	15	8000 62725	14	54
8000 44240	20A	6	8000 53340	7	41	8000 59289	14	24	8000 60474	7	40	8000 62725	20	18
8000 44240	21	17	8000 53504	22A	6	8000 59289	14	39	8000 60475	7	36	8000 62725	20A	8
8000 44240	25	17	8000 53724	18	19	8000 59433	12	19	8000 60476	7	6	8000 62725	20A	9
8000 44240	25	18	8000 54073	23	4	8000 59434	12	21	8000 60477	7	57	8000 62725	25	21
8000 44240	26	4	8000 54477	8	4	8000 59539	4	19	8000 60479	10	1	8000 62726	5	38
8000 45183	6	19	8000 54477	8A	43	8000 59801	5	9	8000 60480	10	11	8000 62726	18	12
8000 45194	2	26	8000 54692	8	7	8000 59801	20A	4	8000 60480	10A	11	8000 62727	2	39
8000 45194	7	71	8000 54692	8A	40	8000 59802	5	7	8000 60501	10	38	8000 62727	11	2
8000 45490	19	5	8000 55101	11	3	8000 59802	20A	3	8000 60501	10A	38	8000 62727	12	33
8000 45495	5	31	8000 55876	23	10	8000 59803	5	8	8000 60502	10	36	8000 62727	15	24
8000 45495	11	17	8000 55878	23	15	8000 59803	20A	2	8000 60502	10A	36	8000 62727	18	18
8000 45495	14	35	8000 55902	18	4	8000 59839	16	5	8000 60504	10	42	8000 62727	19	14
8000 45495	19	22	8000 55903	18	13	8000 59939	3	14	8000 60526	8A	1	8000 62727	25	31
8000 45495	26	5	8000 56359	15	27	8000 59940	2	36	8000 60558	2	33	8000 62728	3	18
8000 45499	21	4	8000 56359	19	32	8000 59941	3	35	8000 60577	7	63	8000 62728	5	10
8000 46881	3	38	8000 56359	22	29	8000 59942	2	28	8000 60577	7	76	8000 62728	11	20
8000 46893	5	33	8000 56359	26	29	8000 59965	8	2	8000 60873	5	23	8000 62728	17	29
8000 46893	5	34	8000 56377	18	6	8000 59965	8A	45	8000 60898	12	40	8000 62728	19	14
8000 46893	11	9	8000 56381	20	4	8000 59975	7	3	8000 60925	5	29	8000 62728	20A	5
8000 46893	15	29	8000 56410	6	31	8000 59976	7	4	8000 60925	5	30	8000 62728	25	8
8000 47422	7	25	8000 56443	13	72	8000 59977	6	17	8000 60925	20A	7	8000 62728	26	10
8000 47662	22	32	8000 56443	24	16	8000 60033	24	11	8000 61064	23	11	8000 62729	5	25
8000 47708	2	20	8000 56443	24	25	8000 60062	23	16	8000 61078	18	14	8000 62729	13	40
8000 47763	7	53	8000 56444	22	34	8000 60062	23	16	8000 61263	7	5	8000 62729	22	37
8000 47824	17	17	8000 56444	25	29	8000 60063	23	16	8000 61269	7	74	8000 62730	2	40
8000 48138	8	13	8000 56444	27	35	8000 60064	23	16	8000 61275	4	18	8000 62730	3	32
8000 48138	8A	31	8000 56767	6	23	8000 60065	23	16	8000 61313	22	30	8000 62730	19	18
8000 48772	22A	20	8000 56806	11	21	8000 60066	23	16	8000 61313	24	12	8000 62730	25	19
8000 48773	22A	19	8000 57155	18	24	8000 60066	23	16	8000 61314	13	63	8000 62730	25	36

Husqvarna

INDICE NUMERICO PROGRESSIVO / NUMERICAL INDEX / INDEX NUMERIQUE
 NUMMERNVERZEICHNIS / ÍNDICE NUMÉRICO PROGRESIVO

TE - TE U.S.A. 410 - 610 / 99
 TC 610 / 99

DISEGNO DRAWING DESSIN ZEICHNUNG DIBUJO	TAVOLA DRAWING TABLE BILD TABLA	INDEX NO. POS. N. INDICE	DISEGNO DRAWING DESSIN ZEICHNUNG DIBUJO	TAVOLA DRAWING TABLE BILD TABLA	INDEX NO. POS. N. INDICE	DISEGNO DRAWING DESSIN ZEICHNUNG DIBUJO	TAVOLA DRAWING TABLE BILD TABLA	INDEX NO. POS. N. INDICE	DISEGNO DRAWING DESSIN ZEICHNUNG DIBUJO	TAVOLA DRAWING TABLE BILD TABLA	INDEX NO. POS. N. INDICE	DISEGNO DRAWING DESSIN ZEICHNUNG DIBUJO	TAVOLA DRAWING TABLE BILD TABLA	INDEX NO. POS. N. INDICE
8000 62730	27	33	8000 65604	20	3	8000 67700	20	20	8000 69722	8A	36	8000 72037	24	29
8000 62731	3	31	8000 65653	6	16	8000 67724	12	27	8000 69723	8	59	8000 72092	10	58
8000 62731	14	29	8000 66101	7	52	8000 67744	2	6	8000 69723	8A	61	8000 72092	10B	72
8000 62731	14	52	8000 66101	7	52	8000 67744	2	6	8000 69723	8A	61	8000 72092	10B	72

DISEGNO DRAWING DESSIN ZEICHNUNG DIBUJO	TAVOLA DRAWING TABLE BILD TABLA	INDEX NO. POS. N. INDICE	DISEGNO DRAWING DESSIN ZEICHNUNG DIBUJO	TAVOLA DRAWING TABLE BILD TABLA	INDEX NO. POS. N. INDICE	DISEGNO DRAWING DESSIN ZEICHNUNG DIBUJO	TAVOLA DRAWING TABLE BILD TABLA	INDEX NO. POS. N. INDICE	DISEGNO DRAWING DESSIN ZEICHNUNG DIBUJO	TAVOLA DRAWING TABLE BILD TABLA	INDEX NO. POS. N. INDICE	DISEGNO DRAWING DESSIN ZEICHNUNG DIBUJO	TAVOLA DRAWING TABLE BILD TABLA	INDEX NO. POS. N. INDICE
8000 75451	9	1	8000 79065	22	17	8000 82044	10B	63	8000 87933	29	2	8000 89588	21	5
8000 75477	24	23	8000 79066	18	30	8000 82212	8A	23	8000 88073	4	19	8000 89829	7	78
8000 75584	2	17	8000 79066	22	23	8000 82213	8A	10	8000 88139	25	28	8000 89882	12	9
8000 75672	11	15	8000 79069	22	3	8000 83395	13	3	8000 88143	12	41	8000 89895	4	10
8000 75673	11	13	8000 79070	22	10	8000 84139	25	48	8000 88216	15	6	8000 89897	4	9
8000 75780	3	2	8000 79071	22	5	8000 84176	14	58	8000 88231	15	21	8000 89899	6	35
8000 75800	12	18	8000 79072	18	31	8000 84177	14	43	8000 88280	17	14	8000 89899	7	12
8000 75801	12	18	8000 79075	18	10	8000 84321	7	65	8000 88280	17	14	8000 89905	2	41
8000 75842	17	11	8000 79096	22	4	8000 84665	12	11	8000 88334	26	25	8000 89908	4	16
8000 75847	10A	43	8000 79097	22	7	8000 84702	13	14	8000 88335	26	26	8000 89910	2	42
8000 75941	19	6	8000 79098	22	2	8000 85243	4	16	8000 88336	26	6	8000 89915	22	11
8000 75957	14	43	8000 79099	22	8	8000 85322	9	7	8000 88337	26	11	8000 89915	27	28
8000 76069	5	24	8000 79100	22	9	8000 85378	3	2	8000 88338	26	2	8000 89919	26	17
8000 76263	14	1	8000 79571	25	26	8000 85419	9	4	8000 88538	27	2	8000 89920	26	17
8000 76289	18	15	8000 79571	27	32	8000 85930	13	10	8000 88602	27	4	8000 89930	13	4
8000 76294	22A	7	8000 79754	17	16	8000 85932	18	29	8000 88603	27	3	8000 89969	25	37
8000 76295	22A	8	8000 79758	25	2	8000 85998	22	16	8000 88690	28	3	8000 90050	2	32
8000 76296	23	6	8000 79767	25	45	8000 85999	22	19	8000 88690	29	3	8000 90052	7	60
8000 76297	22A	8	8000 79789	6	23	8000 86385	13	9	8000 88691	28	11	8000 90054	7	23
8000 76298	22A	7	8000 79790	6	23	8000 86515	22	33	8000 88691	29	11	8000 90055	2	46
8000 76299	23	6	8000 80101	4	21	8000 86522	22	28	8000 3083	15	4	8000 90056	7	79
8000 76338	18	9	8000 80141	27	30	8000 87088	24	21	8000 89085	15	7	8000 90057	7	77
8000 76461	3	3	8000 80142	25	2	8000 87127	5	36	8000 89086	15	8	8000 90058	2	41
8000 75687	17	15	8000 80257	20A	1	8000 87153	18	40	8000 89087	15	9	8000 90061	2	41
8000 76688	17	10	8000 80260	13	54	8000 87243	12	2	8000 89088	15	10	8000 90064	2	42
8000 77373	13	20	8000 80261	27	38	8000 87251	8A	54	8000 89089	15	11	8000 90065	4	16
8000 77391	9	3	8000 80262	27	14	8000 87520	8A	55	8000 89090	15	12	8000 90071	15	1
8000 77413	16	11	8000 80263	27	20	8000 87550	25	14	8000 89091	15	12	8000 90072	15	1

DISEGNO DRAWING DESSIN ZEICHNUNG DIBUJO	TAVOLA DRAWING TABLE BILD TABLA	INDEX NO. POS. N. INDICE	DISEGNO DRAWING DESSIN ZEICHNUNG DIBUJO	TAVOLA DRAWING TABLE BILD TABLA	INDEX NO. POS. N. INDICE	DISEGNO DRAWING DESSIN ZEICHNUNG DIBUJO	TAVOLA DRAWING TABLE BILD TABLA	INDEX NO. POS. N. INDICE	DISEGNO DRAWING DESSIN ZEICHNUNG DIBUJO	TAVOLA DRAWING TABLE BILD TABLA	INDEX NO. POS. N. INDICE	DISEGNO DRAWING DESSIN ZEICHNUNG DIBUJO	TAVOLA DRAWING TABLE BILD TABLA	INDEX NO. POS. N. INDICE
8000 90193	23	6	8000 91475	13	15	8000 91607	13	74	80C0 24058	10	60	8A00 55858	23	14
8000 90197	25	22	8000 91476	13	16	8000 91608	13	74	80C0 24058	10B	73	8A00 59802	20A	12
8000 90334	13	4	8000 91477	13	17	8000 91608	13	74	80C0 53018	17	14	8A00 59964	9	2
8000 90561	13	23	8000 91478	13	18	8000 91609	13	74	80C0 60559	9	5	8A00 60415	2	51
8000 90563	16	1	8000 91479	13	19	8000 91609	13	74	80C0 69337	13	66	8A00 60652	11	19
8000 90596	30	1	8000 91480	13	48	8000 91610	13	74	80C0 69338	13	67	8A00 61348	23	1
8000 90597	24	2	8000 91481	13	21	8000 91611	13	74	80C0 69981	13	51	8A00 62129	22A	23
8000 90600	27	1	8000 91482	13	24	8000 91717	13	75	80C0 87060	25	25	8A00 62797	12	28
8000 90601	2	41	8000 91483	13	25	8000 91718	13	41	80F0 05761	10B	5	8A00 62797	15	30
8000 90648	2	41	8000 91484	13	26	8000 91743	6	18	80F0 87059	19	3	8A00 62797	16	17
8000 90657	30	1	8000 91485	13	27	8000 91839	27	27	80F0 87061	5	19	8A00 63644	2	43
8000 90671	4	16	8000 91486	13	28	80A0 12032	10	6	80F0 87062	5	20	8A00 63649	2	16
8000 90810	15	1	8000 91487	13	29	80A0 12032	10A	6	80G0 91044	28	8	8A00 64708	18	1
8000 91038	28	9	8000 91488	13	30	80A0 66202	14	17	80G0 91044	30	8	8A00 64983	23	9
8000 91038	29	9	8000 91489	13	32	80A0 66222	2	50	80H0 12032	10B	6	8A00 65442	6	24
8000 91039	28	10	8000 91490	13	31	80A0 66800	5	3	80H0 70209	19	10	8A00 65503	13	56
8000 91039	29	10	8000 91491	13	34	80A0 67186	5	1	80K0 91044	29	8	8A00 66525	6	44
8000 91040	28	4	8000 91492	13	34	80A0 67248	5	21	80K0 91044	30	8	8A00 66661	14	32
8000 91040	29	4	8000 91493	13	36	80A0 67720	12	25	80L0 91044	29	8	8A00 67216	7	55
8000 91041	28	5	8000 91494	13	37	80A0 69551	15	32	80U0 12041	10A	4	8A00 67422	22A	1
8000 91041	29	5	8000 91495	13	37	80A0 70558	13	70	80U0 12041	10B	4	8A00 67444	10B	66
8000 91042	28	6	8000 91495	13	46	80A0 70581	24	15	8A00 07001	19	17	8A00 67545	15	25
8000 91042	29	6	8000 91495	13	46	80A0 70581	24	24	8A00 15960	2	47	8A00 67545	20A	13
8000 91043	28	7	8000 91496	13	37	80A0 73426	14	16	8A00 15960	3	34	8A00 67545	21	16
8000 91043	29	7	8000 91496	13	46	80A0 73456	14	15	8A00 18648	22A	2	8A00 67545	21	16
8000 91156	13	50	8000 91496	13	46	80A0 74388	14	7	8A00 28182	7	2	8A00 67932	10	43
8000 91157	13	49	8000 91497	13	39	80A0 75671	11	9	8A00 28183	4	2	8A00 67997	13	52
8000 91160	13	50	8000 91499	13	45	80A0 78265	12	31	8A00 35794	3	5	8A00 67997	25	38
8000 91161	13	49	8000 91500	13	46	80A0 86523	22	27	8A00 36022	6	38	8A00 68196	6	30
8000 91236	15	2	8000 91500	13	46	80A0 86525	22	26	8A00 37003	7	26	8A00 68201	6	28
8000 91237	15	3	8000 91501	13	46	80A0 87800	19	26	8A00 38350	8	52	8A00 69003	19	27
8000 91239	15	5	8000 91501	13	46	80A0 89953	12	6	8A00 38350	8A	57	8A00 69056	14	51
8000 91240	15	13	8000 91502	13	46	80A0 89962	12	7	8A00 40877	10	51	8A00 69138	16	13
8000 91241	15	14	8000 91503	13	47	80B0 40596	10A	56	8A00 40877	10A	51	8A00 69282	14	57
8000 91242	15	19	8000 91504	13	41	80B0 43928	12	10	8A00 40877	10B	65	8A00 69285	16	4
8000 91245	15	3	8000 91505	13	22	80B0 63846	10B	76	8A00 48137	8	10	8A00 69315	13	57
8000 91246	15	6	8000 91506	13	6	80B0 66630	20	1	8A00 48137	8A	34	8A00 69782	11	1
8000 91246	15	6	8000 91507	13	5	80B0 75766	2	24	8A00 48188	6	1	8A00 70266	18	20
8000 91288	1	9	8000 91508	13	21	80B0 84173	3	25	8A00 50322	3	47	8A00 72283	21	22
8000 91289	1	14	8000 91509	13	45	80B0 84174	3	16	8A00 55241	22A	17	8A00 72284	5	32
8000 91473	13	7	8000 91510	13	41	80C0 05761	10	59	8A00 55248	10B	1	8A00 72289	3	42
8000 91474	13	13	8000 91519	13	55	80C0 05761	10B	74	8A00 55532	6	2	8A00 72411	21	8

DISEGNO DRAWING DESSIN ZEICHNUNG DIBUJO	TAVOLA DRAWING TABLE BILD TABLA	INDEX NO. POS. N. INDICE	DISEGNO DRAWING DESSIN ZEICHNUNG DIBUJO	TAVOLA DRAWING TABLE BILD TABLA	INDEX NO. POS. N. INDICE	DISEGNO DRAWING DESSIN ZEICHNUNG DIBUJO	TAVOLA DRAWING TABLE BILD TABLA	INDEX NO. POS. N. INDICE	DISEGNO DRAWING DESSIN ZEICHNUNG DIBUJO	TAVOLA DRAWING TABLE BILD TABLA	INDEX NO. POS. N. INDICE	DISEGNO DRAWING DESSIN ZEICHNUNG DIBUJO	TAVOLA DRAWING TABLE BILD TABLA	INDEX NO. POS. N. INDICE
8A00 72411	21	8	8B00 71233	21	1	8E00 67545	3	26						
8A00 72425	6	39	8B00 71234	21	2	8E00 67545	19	11						
8A00 72621	23	19	8B00 71759	27	20	8E00 69056	12	38						
8A00 74181	22	20	8B00 78437	2	30	8E00 74372	16	6						
8A00 74718	22A	11	8B00 80428	21	5	8E00 90111	12	1						
8A00 75042	22A	18	8B00 82861	8	11	8E00 91498	23	16						
8A00 75153	16	3	8B00 82861	8A	32	8F00 10789	3	46						
8A00 75764	7	44	8B00 87148	10B	5	8F00 28183	4	2						
8A00 77741	22	11	8B00 91498	23	16	8F00 28183	7	30						
8A00 78447	12	37	8B00 91498	23	16	8F00 38110	11	14						
8A00 78765	2	31	8C00 24058	10	3	8F00 56515	23	16						
8A00 79072	18	31	8C00 24058	10A	3	8F00 91498	23	16						
8A00 79766	25	45	8C00 27690	7	59	8G00 70208	19	9						
8A00 85355	2	30	8C00 28183	4	2	8GA0 05761	10	5						
8A00 86526	22	25	8C00 36022	6	38	8GA0 05761	10A	5						
8A00 89851	19	12	8C00 50322	3	47	8H00 28183	4	2						
8A00 89882	12	42	8C00 61121	14	20	8P00 12041	10B	4						
8A00 89938	19	12	8C00 61348	23	1	8Q00 27910	10	2						
8A00 90111	12	1	8C00 63811	4	17	8Q00 27910	10A	2						
8A00 90170	12	1	8C00 67422	22A	1	8Q00 27910	10B	2						
8AA0 21626	21	18	8C00 67545	19	20									
8AA0 65340	24	1	8C00 67997	9	11									
8AA0 65340	27	21	8C00 67997	14	23									
8AA0 73877	14	42	8C00 67997	19	28									
8AN0 12041	10	4	8C00 69112	12	15									
8B00 33607	23	2	8C00 69319	13	1									
8B00 35794	3	5	8C00 70034	25	23									
8B00 36022	6	38	8C00 71027	4	17									
8B00 38110	7	30	8C00 71233	21	1									
8B00 38752	20	12	8C00 71234	21	2									
8B00 42029	14	4	8C00 71759	24	5									
8B00 42029	16	10	8C00 72621	23	19									
8B00 50322	3	47	8C00 79783	6	24									
8B00 56768	6	24	8C00 91498	23	16									
8C00 64983	23	9	8CA0 50798	22	31									
8B00 65572	22A	22	8D00 28183	4	2									
8B00 66525	13	71	8D00 36022	6	38									
8B00 66525	24	13	8D00 67545	3	30									
8B00 66525	24	22	8D00 79785	6	24									
8B00 69282	19	25	8D00 91498	23	16									
8B00 69429	25	10	8E00 30053	8	29									
8B00 69429	25	46	8E00 30053	8A	20									