

Service manual

Öhlins single shock absorbers

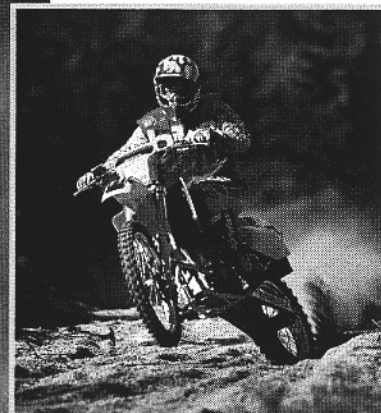

**Type
46ER
46DR**



**Type
46ERS
46DRS**



**Type
46PRC**



**Type
46HRC**



**Type
46HRC SL**

Traction, handling,
comfort and safety



ADVANCED SUSPENSION TECHNOLOGY

Safety signals

Particularly important information is distinguished in this manual by the following notations:



The Safety Alert Symbol means:
ATTENTION!
BECOME ALERT!
YOUR SAFETY IS INVOLVED!

WARNING

Failure to follow **WARNING** instructions could result in severe injury or death to the shock absorber operator, a bystander or a person inspecting or repairing the shock absorber.

CAUTION!

CAUTION indicates special precautions that must be taken to avoid damage to the shock absorber.

NOTE

A **NOTE** provides key information to make procedures easier or clear.

Introduction

This Service Manual covers the service of all Öhlins Single shock absorbers for motorcycles.

The shock absorbers are divided into two groups depending on their design:

1. Öhlins Type 46ER/DR, (old type 1).
Öhlins Type 46ERS/DRS, (old type 2 with hydraulic spring preload adjuster).
2. Öhlins Type 46PRC, (old type 3A).
Öhlins Type 46HRC, (old type 3B).
Öhlins Type 46 HRCS, (old type 4A).
Öhlins Type 46PBRCS, (old type 4B).

Single chapters covers the service of the three piston shafts used in the shock absorbers, the service of the hydraulic spring preload adjuster used on 46HRCS, 46ERS, 46DRS and the replacement of the adjustment wheel and end eye bearings on all type of shock absorbers.

All information, illustration, photographs and specifications contained in this manual are the latest product information available at the time of publication.

Make sure you have all the necessary tools before you start working on the Öhlins shock absorber, please see *Service tools* on page 2.

This manual is presented to make the service of the Öhlins shock absorbers as easy and as safe as possible with maximum performance out of the serviced shock absorber as a result!

Öhlins Racing AB can not be held responsible for any damage to spare parts or person if the mounting-, main- and servicing instructions are not followed exactly.

Also no guarantee can be given for the performance and reliability if these instructions are not followed.

Contents

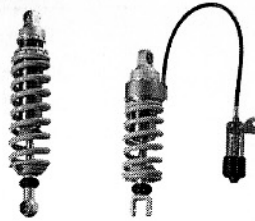

Type 46ER, 46DR, 46ERS, 46DRS

Shock absorber	4
Piston rod (all types)	11
End eye / clevis, ball joints	16



Type 46PRC, 46HRC Type 46HRCS, 46PRCS

Shock absorber	7
Piston rod (all types)	11
End eye / clevis, ball joints	16

Hydraulic spring adjuster

All types	17
-----------	----

Technical info

All types	19
-----------	----

Tools, oil and grease

Service tools, oil and grease	2
-------------------------------	---

Öhlins new type system

- 46** Piston diameter in mm.
- E** Emulsion type shock absorber.
- D** Shock absorber with dividing piston.
- P** Piggyback mounted reservoir.
- H** Hose mounted reservoir.
- R** Adjustable rebound damping.
- C** Adjustable compression damping.
- L** Adjustable length.
- S** Hydraulic spring preload adjuster.

© 1997 by Öhlins Racing AB
1st edition, September 1997

Part No: 7600-01, Service manual single shock absorbers
All rights reserved.

Any reprinting or unauthorized use
without the written permission of
Öhlins Racing AB is expressly prohibited.
Printed in Sweden.

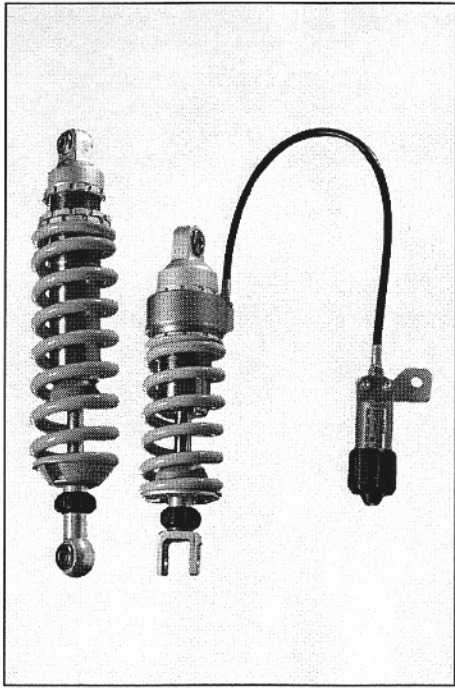

Dismantling

Type 46ER

Old type 1 and 2 emulsion type
without dividing gas piston

46DR

Old type 1 and 2

with dividing gas piston.

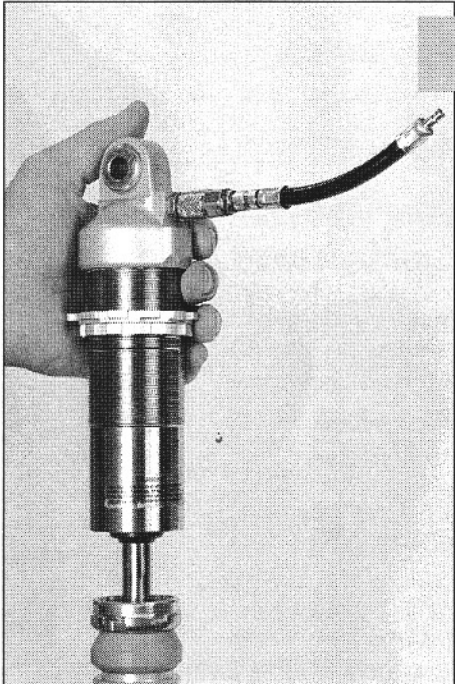

a

Remove the spring from the
shock absorber (if fitted).
Use spring tool 747-01.

⚠ WARNING

*Releasing high pressure gas
can be hazardous.*

*Never perform any service
until the nitrogen gas pressure
has been released.*

Release the nitrogen gas
pressure with needle 1781-01.

On type 46ER (emulsion), hold
the shock absorber upright for
approximately one minute,
before releasing the nitrogen
pressure.

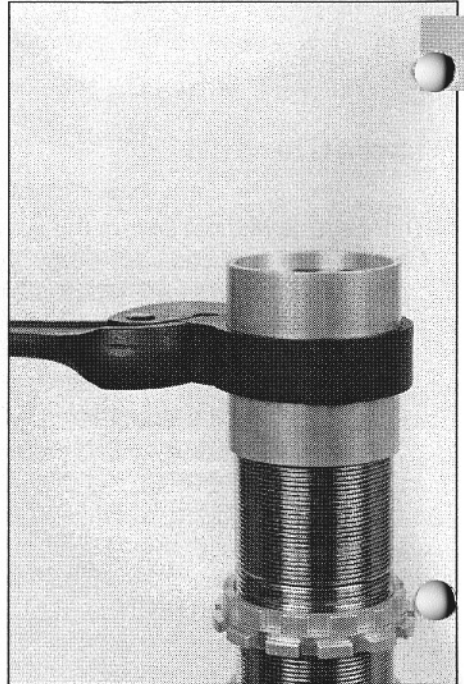

d

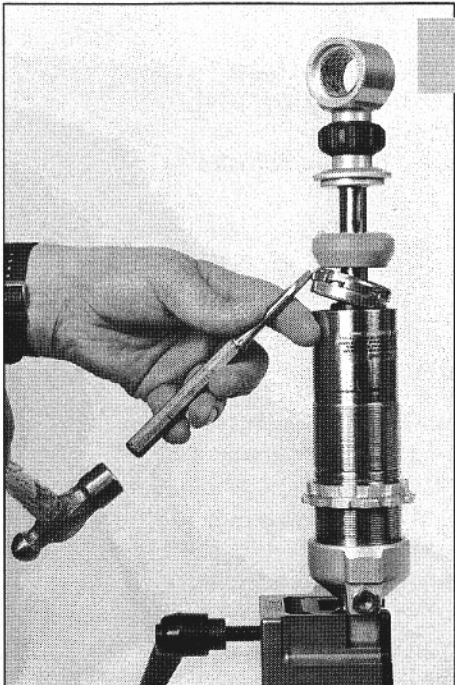

b

Fasten the shock absorber in
Öhlins vice 773-01.

Remove the end cap from the
body tube.

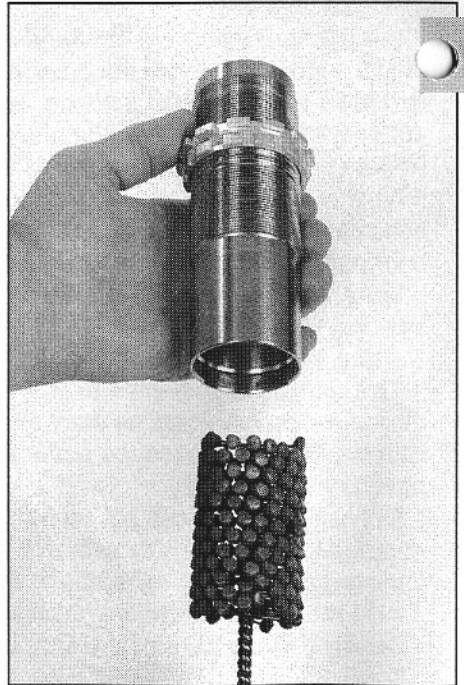

e

NOTE

Avoid scratching the inner surface of the shock absorber body to avoid oil leaks.

Depress the seal head approximately 15 mm.

Release and remove the circlip from the body tube with tool 715-01.

Lift up the piston shaft assembly from the body tube and drain the oil.

NOTE

On type 46ER (emulsion) there is no need to take off the cylinder head.

On type 46DR (with dividing gas piston), fasten the shock absorber in a vice, use soft jaws.

Heat up the cylinder head to facilitate removal (the cylinder head is secured with Loctite).

Remove the body tube from the cylinder head, use tool 737-01 and 738-01.

Remove the centre screw in the piston, use tool 757-01 to hold the piston from moving.

Remove the piston.

Hone the body tube with hone brush 1728-03.

Clean all parts.

Continue with "Piston shaft assembly" on page 11.

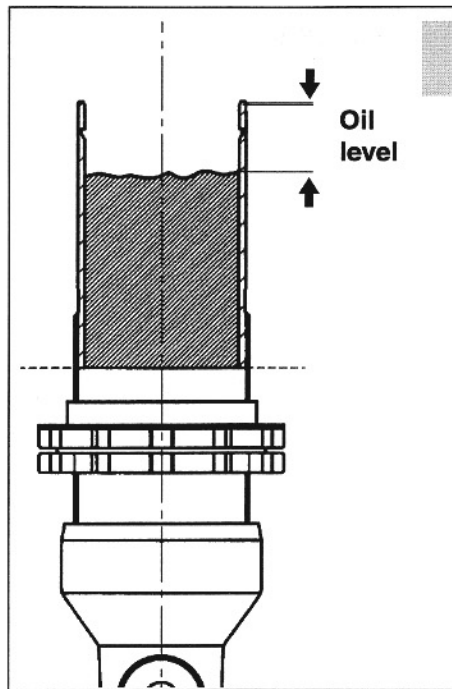

a

Assembling Type 46ER

Fasten the body tube in Öhlins vice 773-01.

NOTE

Use only Öhlins shock oil to guarantee the right function.

Fill the body tube with Öhlins shock oil 105-01, to the recommended oil level according to the specification card.

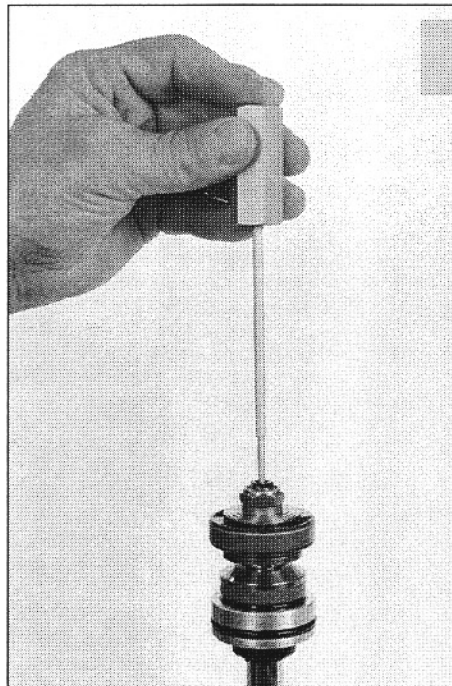

b

Make sure that the needle is fully open before installing the piston shaft.

Install the piston shaft assembly into the body tube.

Install the circlip and make sure it is properly seated.

Knock down the end cap with a plastic hammer.

NOTE

Shock absorbers without dividing gas piston must be pressurised "standing up" i.e. with the head facing upwards

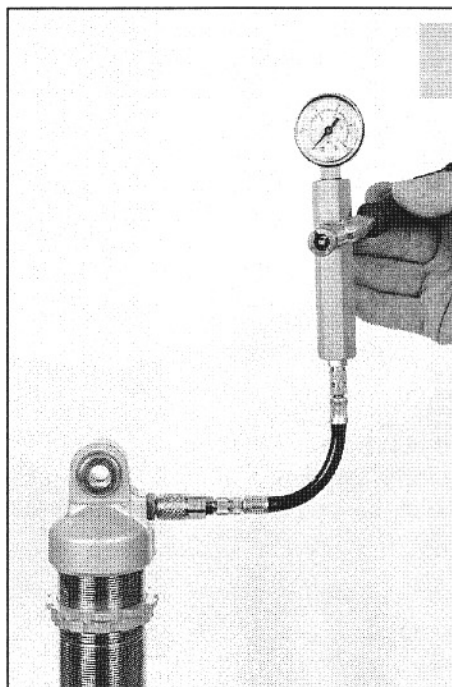

c

Pressurise the shock absorber with nitrogen gas according to the specification card.

Use pressure gauge 1781-01.

Set the rebound adjustment wheel to the recommended click according to the specification card.

Make an easy function control by pushing the shaft up and down.

Install the spring (if fitted) and set the initial spring preload according to the specification card.

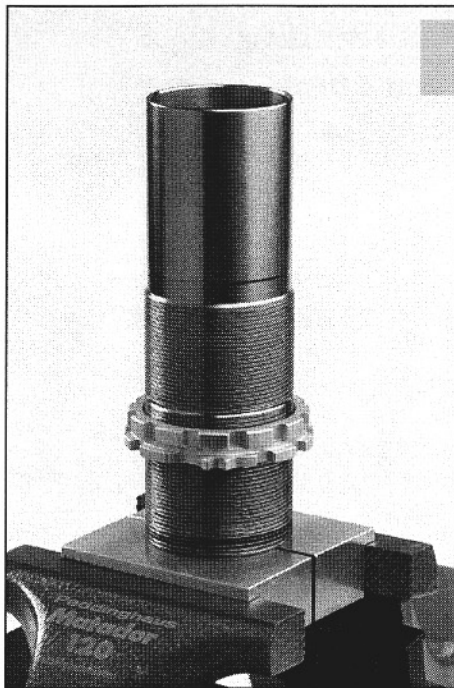

a

Assembling Type 46DR

On type 46DR (with dividing gas piston), fasten the body tube with clamping tool 765-01 in a vice.

Make sure that the adjustment needle is fully open before installing the piston shaft.

Install the piston shaft assembly into the body tube.

Install the circlip and make sure it is properly seated.

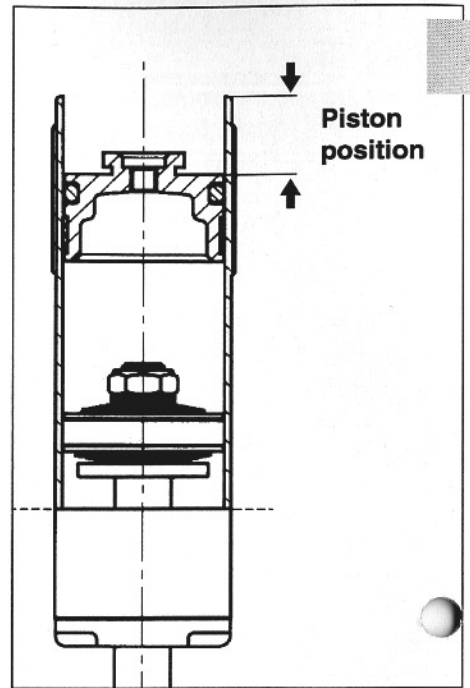

d



b

Knock down the end cap into the body tube with a plastic hammer.

Turn the body tube around so that the shaft is facing down.

NOTE

Use only Öhlins shock oil to guarantee the right function.

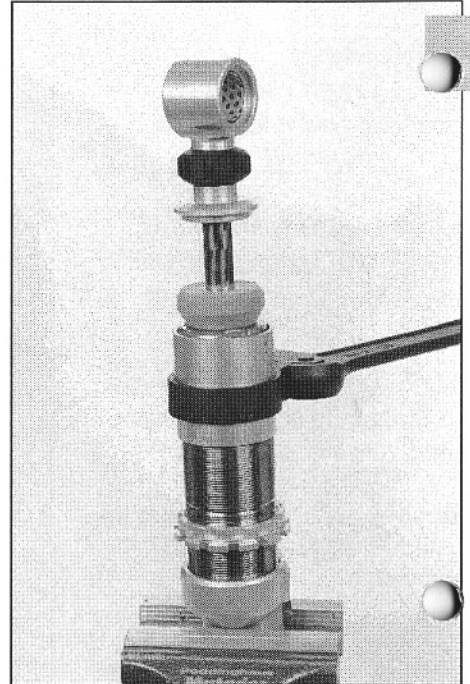

e

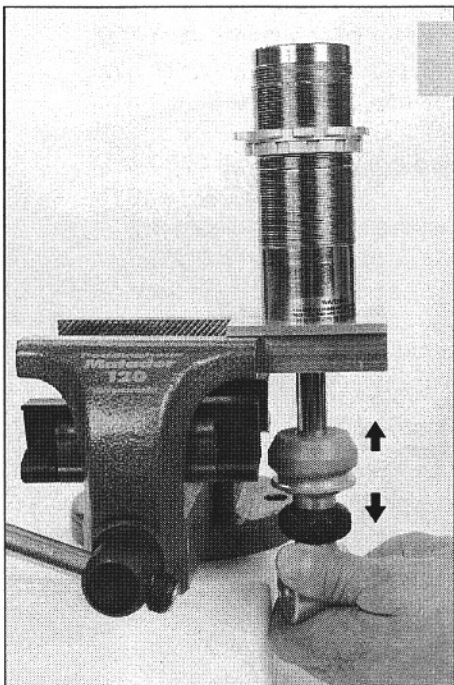

c

Fill the body tube with Öhlins shock oil 105-01, to approximately 15 mm from the top of the tube.

Bleed out the remaining air by pushing the shaft up and down in the tube.

Do not push hard, just move the shaft smoothly.

NOTE

To obtain maximum oil volume, pull out the shaft to it's fully extended length before installing the dividing gas piston.

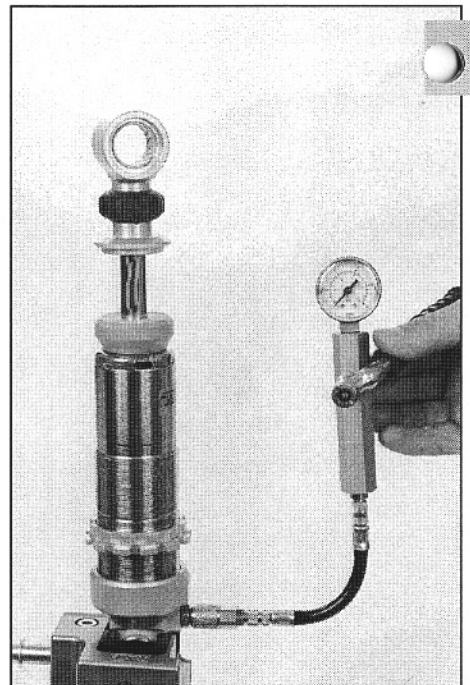

f

Inspect the dividing gas piston for wear and damage.

NOTE

Use *Öhlins grease 146-01* on all o-rings and seals.

Replace the o-rings and the piston ring with new ones.

Install the dividing gas piston into the body tube and set the piston position with a vernier. See the specification card for the correct piston position.

Install the centre screw and use tool 757-01 to hold the dividing gas piston.

Wipe the remaining oil off.

Clean the body tube thread with cleaner and use Loctite 270 on the thread when installing the cylinder head.

Turn the body tube around and fasten the cylinder head in a vice with soft jaws.

Use tool 737-01 and 738-01 to tighten the body tube.

⚠ WARNING

Do not use inflammable gas to pressuring the shock absorber. Use nitrogen gas N2 only!

Pressurise the shock absorber with nitrogen gas according to the specification card.

Use pressure gauge 1781-01.

Set the rebound adjustment wheel to the recommended click according to the specification card.

Make an easy function control by pushing the shaft up and down.

Install the spring (if fitted) and set the initial spring preload according to the specification card.

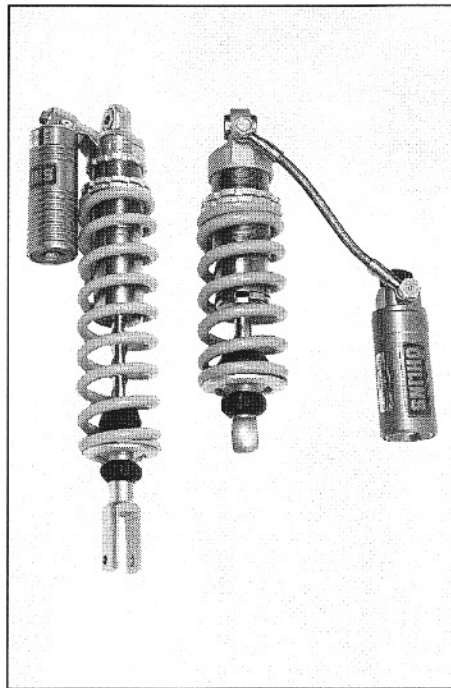

Dismantling

Type 46PRC

Old type 3A with piggyback mounted reservoir.

Type 46HRC

Old type 3B with hose mounted reservoir.

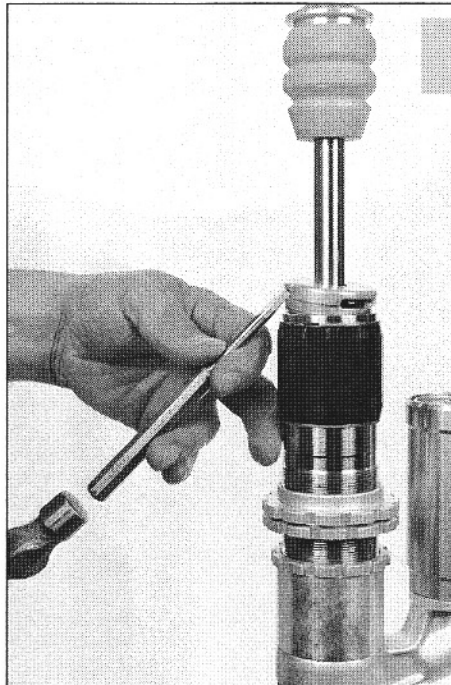

Remove the spring from the shock absorber, if fitted.

Use spring tool 747-01.

Fasten the shock absorber in Öhlins vice 773-01.

Remove the end cap from the body tube.

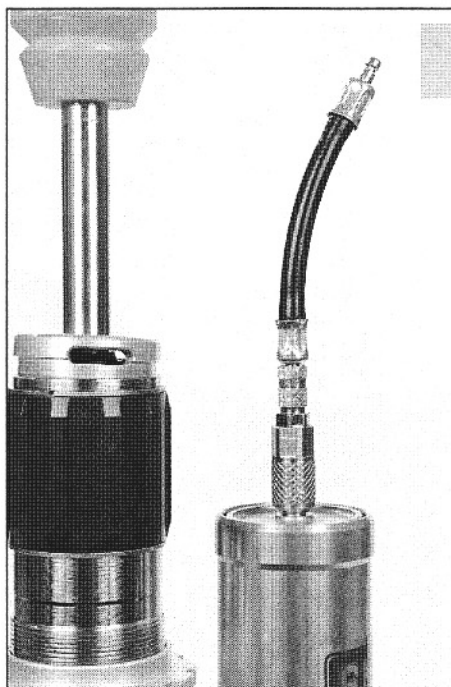

⚠ WARNING

Releasing high pressure gas can be hazardous.

Never perform any service until the nitrogen gas pressure has been released.

Release nitrogen gas pressure with needle 1781-01.

Press the reservoir end cap into the reservoir tube.

Release and remove the circlip in the reservoir, use tool 715-01.

Lift up the reservoir end cap, use tool 720-03.

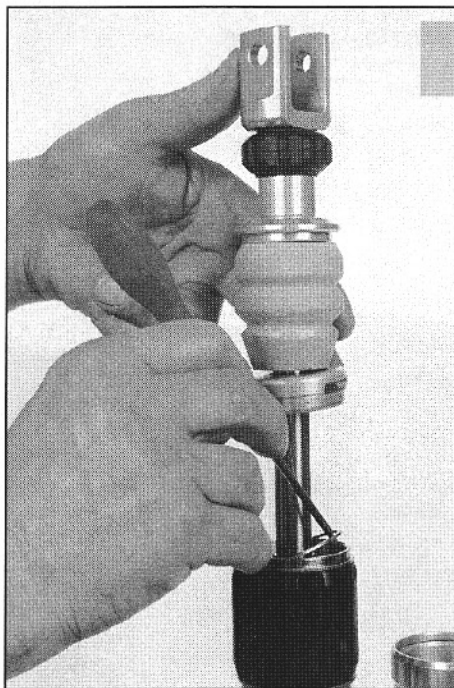

c

NOTE

Avoid scratching the inner surface of the shock absorber body to avoid oil leaks.

Depress the seal head approximately 15 mm.

Release and remove the circlip from the body tube with tool 715-01.

Lift up the piston shaft assembly from the body tube and drain the oil.

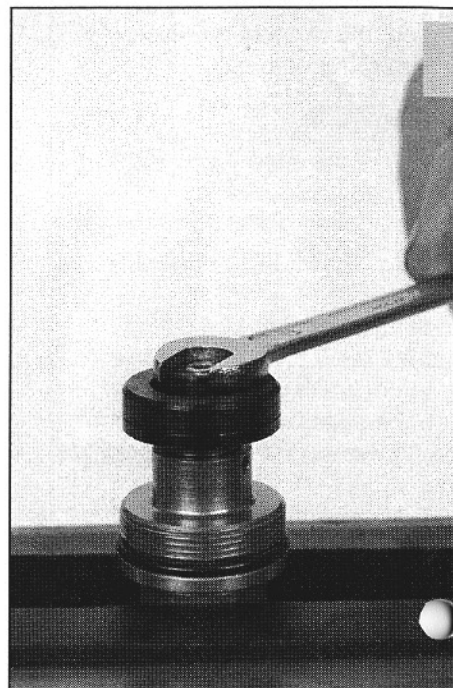

f

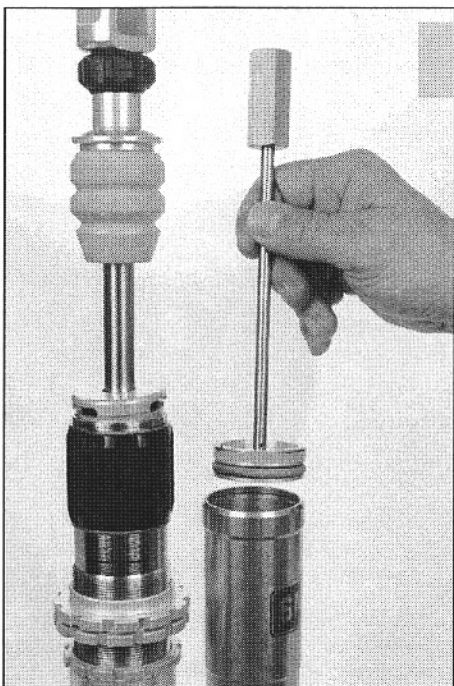

d

Lift up the dividing gas piston with tool 720-02.

Remove the compression adjuster valve assembly in order to drain the remaining oil.

Hone the body tube with tool 1728-03.

Clean all parts.

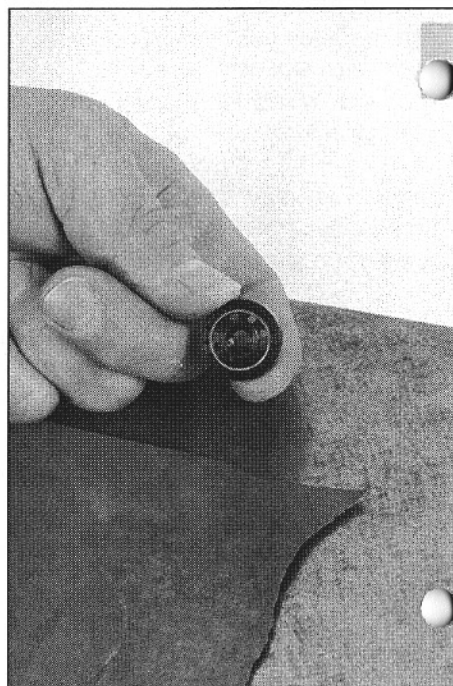

g



e

If the body tube or the reservoir tube has to be replaced, heat up cylinder head to facilitate removal (the cylinder head is secured with Loctite).

Use tool 737-01 and 738-01, to remove body tube.

Tool 737-04 and 738-01 to remove reservoir tube.

NOTE

Hone the new body tube before installing it with tool 1728-03.

Hone the new reservoir tube before installing it with tool 1728-01.

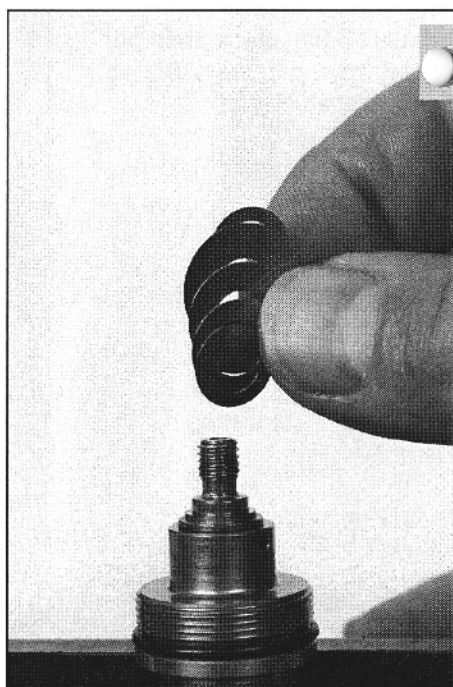

h

Fasten the valve assembly in a vice with soft jaws and remove the one way valve from the valve body.

Inspect and replace the shims if necessary.

Continue with "Piston shaft dismantling" on page 11.

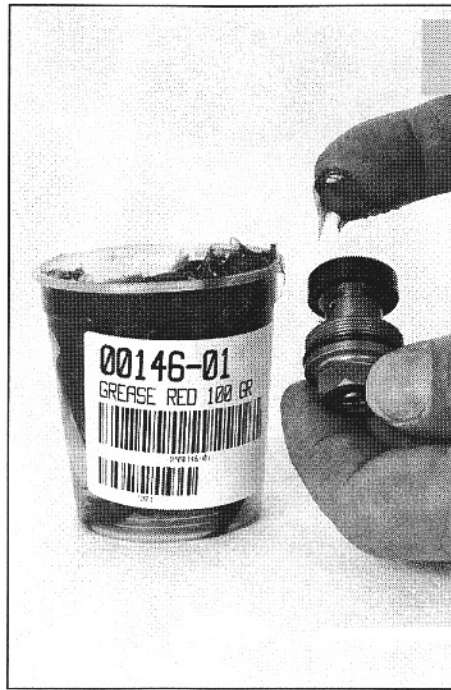

a

Assembling Type 46PRC Type 46HRC

Fasten the shock absorber body tube in Öhlins vice 773-01.

NOTE

Use Öhlins grease 146-01 on all o-rings and seals.

Replace the o-rings and the piston ring with new ones.

Apply a thin layer of Öhlins red grease 146-01 on the o-rings and the compression valve assembly.

Before assembling the valve body, make a quick check on a surface plate with # 1200 grit paper.

Make a rotating figure on the shim side sealing surface to make sure this surface is flat.

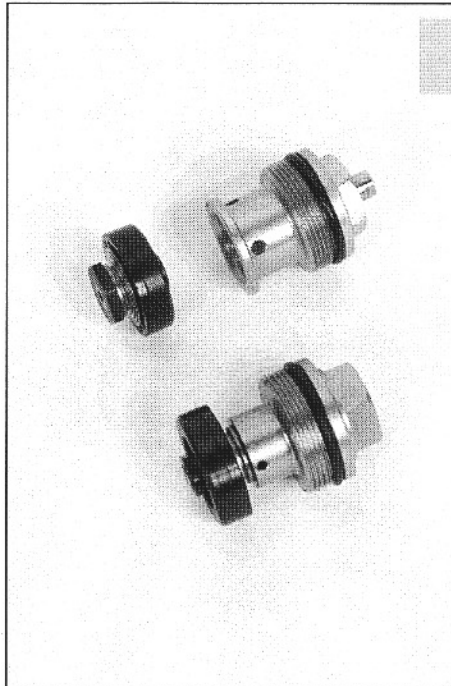

b

Install the compression valve assembly, in the correct order, into the cylinder head or the remote reservoir and tighten the end cap.

Tightening torque:
Hose mounted reservoir: 12 Nm.
Piggyback type: 18 Nm.

Close the compression needle valve (clock wise).

Install the shim stack and tighten the compression valve.

Tightening torque: 6 Nm.



c

Apply a thin layer of Öhlins grease 146-01 in the reservoir tube.

NOTE

Use only Öhlins shock oil to guarantee the right function.

Fill the reservoir tube with Öhlins shock oil 105-01, all the way up to the circlip groove.

Inspect the dividing gas piston for wear and damage.

Replace the o-rings with new ones, replace the piston ring if necessary.

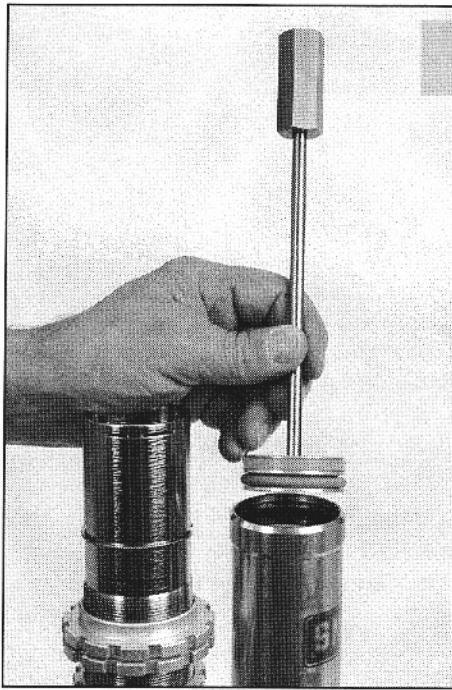

d

Install the dividing gas piston into the reservoir tube.

Push the dividing gas piston to the bottom of the reservoir tube, use positioning pin 720-02.

Fill the main body tube with Öhlins shock oil 105-01, to approximately 15 mm below the circlip groove.

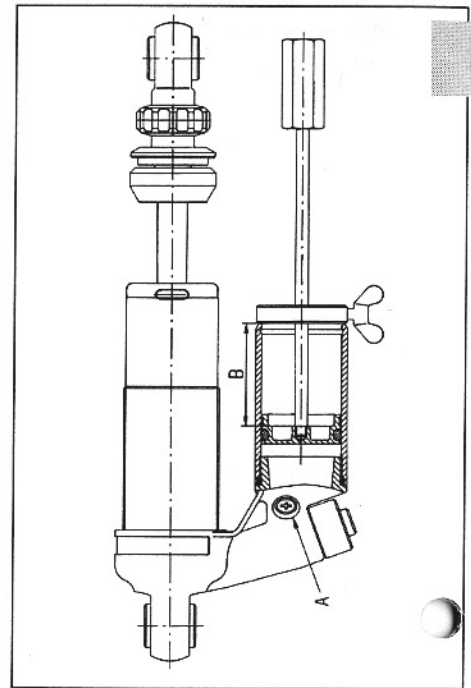

g

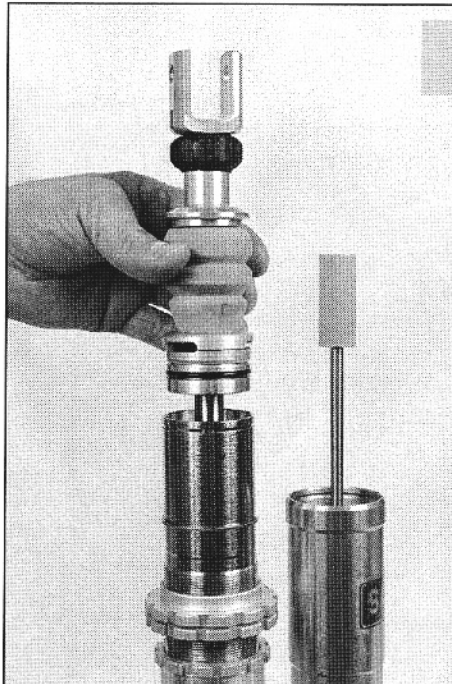

e

Install the piston shaft assembly into the body tube, make sure the adjustment needle is fully open.

Make sure to bleed out all air by pushing the piston shaft up and down in the body tube.

Position the shaft half way down in to the body tube.

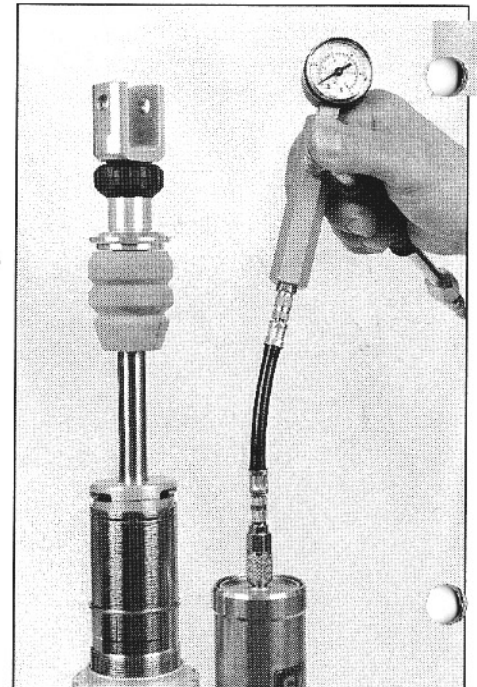

h

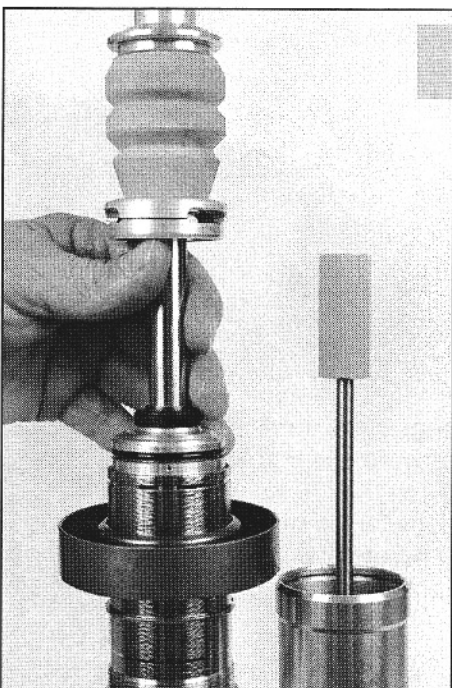

f

Fill oil to the top of the body tube.

Open the compression valve (anti clock wise).

Press down the seal head assembly into the body tube and use tool 1753-01 to avoid oil spill.

Install the circlip and make sure it is properly seated.



i

Use positioning pin 720-02 to set the correct gas piston position "B".

If necessary, drain oil through bleed screw "A".

<u>Reservoir length (mm)</u>	<u>Gas piston position (mm)</u>
80	47
90	57
110	77
120	87

Use end cap pin 720-03 to install the reservoir end cap.

Install the end cap circlip.

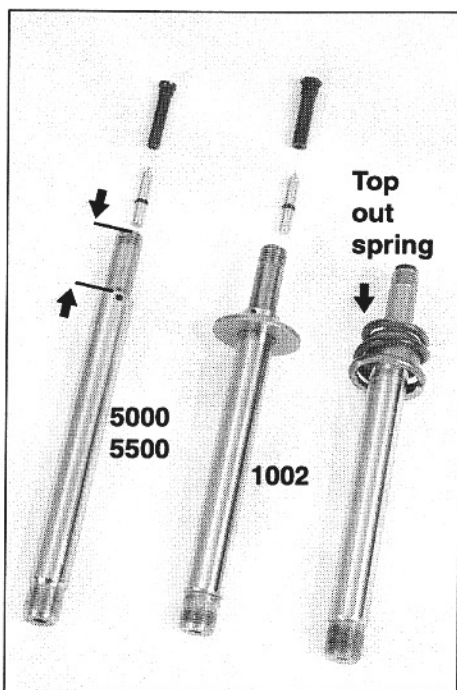

Dismantling **Piston shaft all types**

NOTE

Three types of shafts are used.

1. 1002 with a circlip and a press-fitted stop washer.
2. 5000 without the circlip and the press-fitted stop washer.
3. New type 5500. This shaft locks the same as the 5000 shaft, but has a longer top section with space for a thicker shim stack.

The 5000 and 5500 shafts also have a new needle and shaft jet.

Some shafts have a "top out" spring fitted. This application is most common on racing shocks.

▲ WARNING

Do not use inflammable gas to pressuring the shock absorber. Use nitrogen gas N2 only!

Pressurise the shock absorber with nitrogen gas according to the specification card.

Use pressure gauge 1781-01.

Use soapy water to check for gas leakage.

Wipe of the remaining oil on top of the seal head with a rag.

Knock down the end cap into body tube with a plastic hammer.

Set the rebound and compression adjustment knobs to the recommended click according to the specification card.

Make an easy function control by pushing the shaft up and down.

Install the spring (if fitted) and set the initial spring preload.

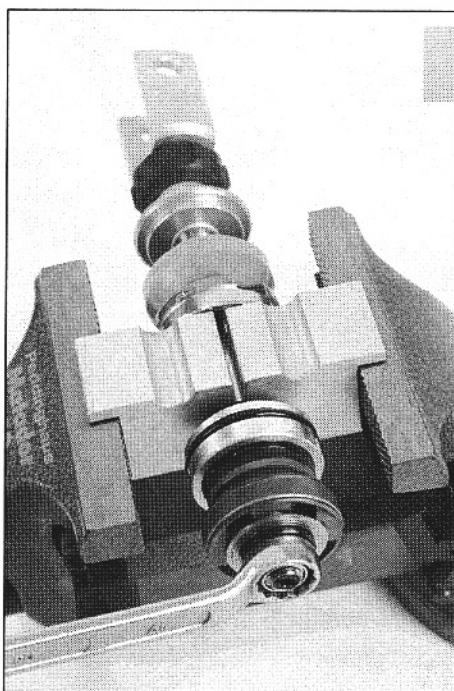

a

Dismantling **Piston shaft 1002**

Fasten the shaft assembly in a vice with soft jaws 727-03.

Remove the end eye (clevis) from the shaft.

NOTE

Put the shim stacks on the bench in the right order as shown on the specification card.

Remove the lock nut, the rebound shim stack, the damper piston and the compression shim stack.

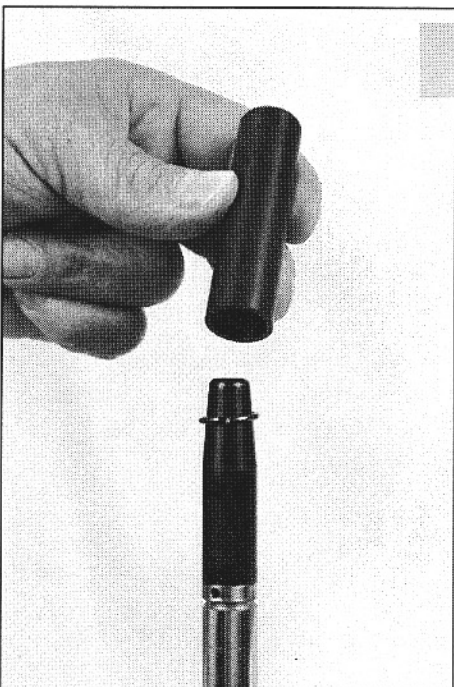

b

Remove all other parts from the shaft.

Put them in the right order on the bench.

Inspect all parts for wear and damage.

Inspect the shaft for bends and scratches.

NOTE

If the shaft has to be replaced always order the circlip together with the shaft, because the circlip is difficult to take off.

Use tool 1720-01 to fit the new circlip.

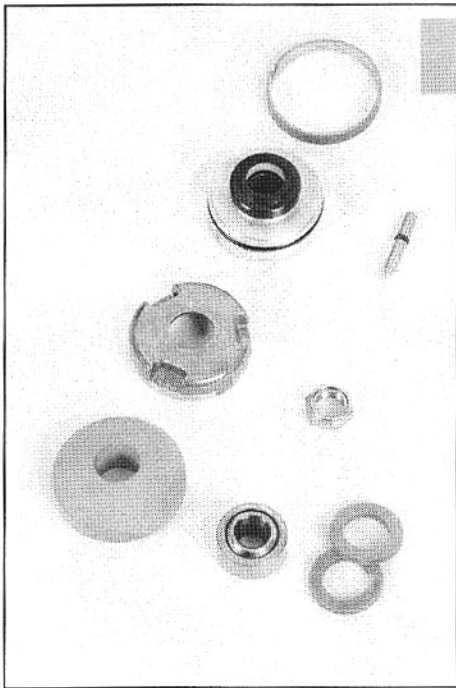

c

NOTE

If the right part order is lost, use the figure on page 15 as a guide.

Always replace the piston ring and the seal head assembly with new ones.

Replace the end cap, the lock nut, the bump rubber and the o-ring on the adjustment needle if necessary.

Replace the ball joint bearing and the dust seals on the end eye if necessary.

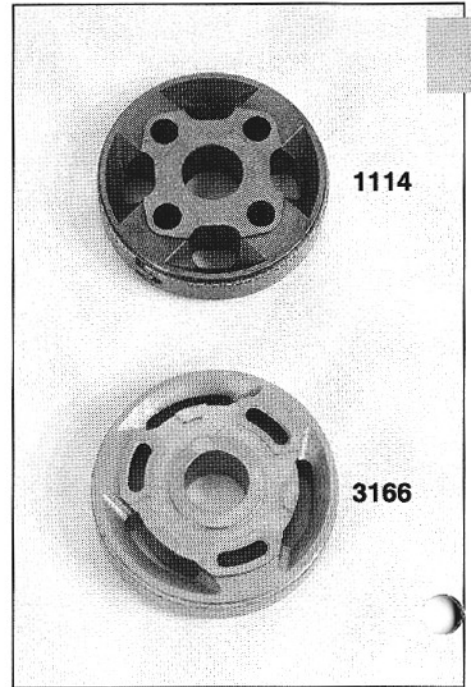

c

1114

3166

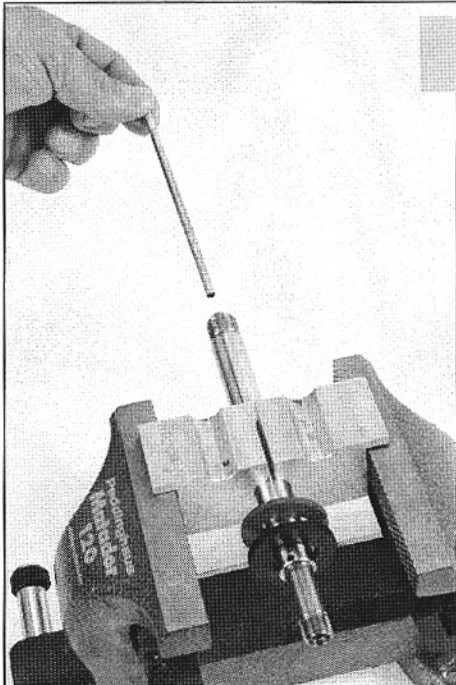

a

**Assembling
Piston shaft 1002**

Again fasten the shaft in a vice with soft jaws 727-03.

NOTE

Use Öhlins grease 146-01 on all o-rings, the adjustment pin and all seals.

Fit the internal spacers if fitted, and the seal head assembly.

Fit the end cap and the bump rubber.

Install the adjustment pin into the shaft.

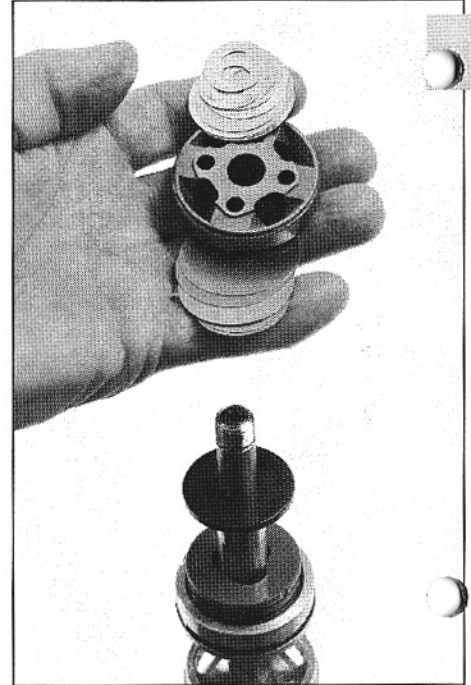

d



b

NOTE

Before installing the attachment end eye (clevis) make sure that the adjustment knob is fully open (anticlockwise).

Fit the attachment end eye (clevis)

Use Loctite 270 on the thread.

Fit the adjustment needle and the shaft jet.

Use Loctite 242 on the thread.

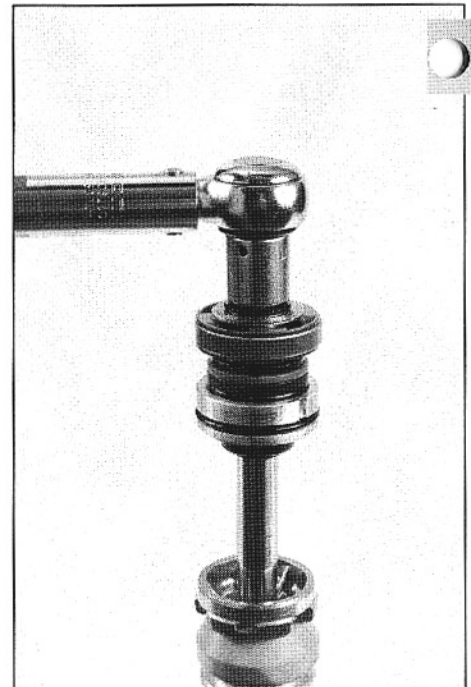

e

CAUTION!

The chamfered side of the shim support washer must face away from the shim stack.

There are two piston types available since Sep. 1997:

Piston 1114- (old type): the rebound side (four circular 4,7 mm holes, 34 mm shim diameter) must face the lock nut!

Piston 3166- (new type): the rebound side (three oval holes, shim diameter 36 mm) must face the lock nut!

Fit the shim support washer.

Fit the compression shim stack, the piston and the rebound shim stack.

Fit the washer and the lock nut.

Tightening torque: 30 Nm.

Use a torque wrench when tighten the nut.

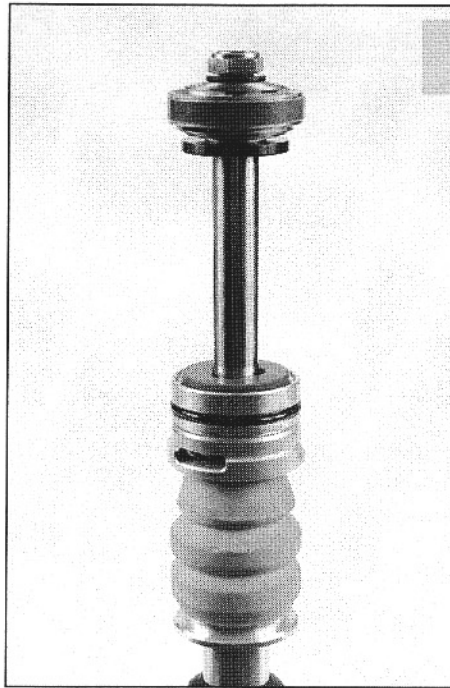

a

Dismantling Piston shaft 5000 and 5500

NOTE

There is no need to take off the end eye (clevis) during a normal service.

All parts can be taken off the shaft from the piston side.

Fasten the end eye (clevis) with soft jaws in a vice, with the piston facing upwards.

Remove the lock nut, the rebound shim stack, the damper piston and the compression shim stack.

Remove all other parts from the shaft.

Put them in the right order on the bench.

NOTE

If the right part order is lost, use the figure on page 15 as a guide.

Inspect all parts for wear and damage.

Inspect the shaft for bends and scratches.

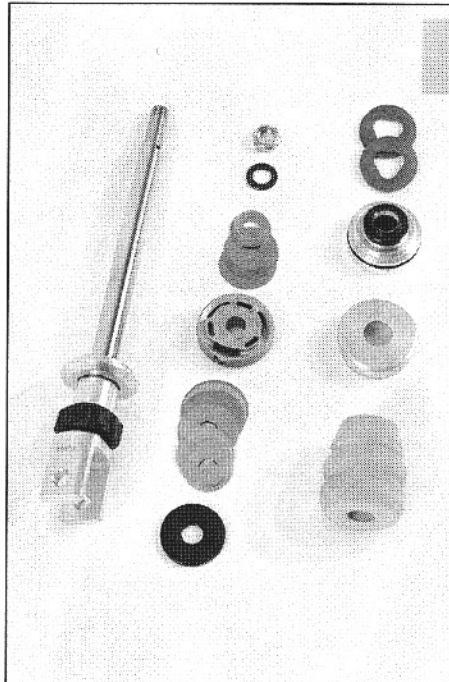

b

Replace the piston ring and the seal head assembly with new ones.

Replace the end cap, the lock nut and the bump rubber if necessary.

NOTE

The end eye (clevis) has to be taken off from the shaft if the o-ring on the adjustment needle has to be replaced.

Replace the o-ring on the adjustment needle if necessary.

Replace the ball joint bearing and the dust seals on the end eye if necessary.

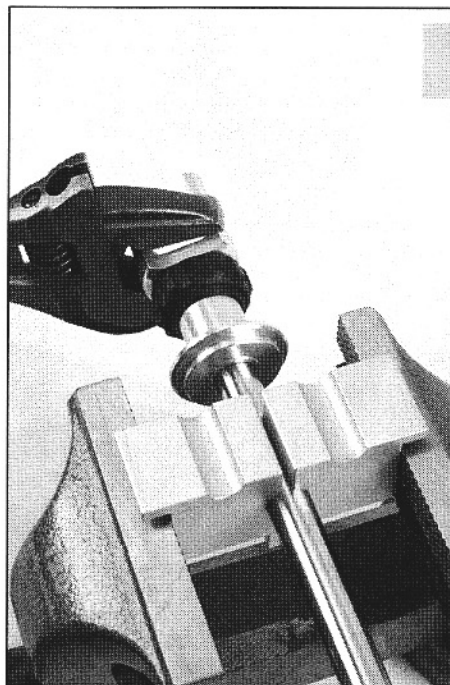

c

a

Assembling Piston shaft 5000 and 5500

Again fasten the end eye (clevis) with soft jaws in a vice.

NOTE

Use Öhlins grease 146-01 on all o-rings, the adjustment pin and all seals.

Fit the bump rubber and the end cap.

Fit the sleeve 1785-02 on the shaft end, then install the seal head assembly.

Fit the internal spacers if fitted.

CAUTION!

The chamfered side of the shim support washer must face away from the shim stack.

There are two piston types available since Sep. 1997:

Piston 1114- (old type): the rebound side (four circular 4,7 mm holes, 34 mm shim diameter) must face the lock nut!

Piston 3166- (new type): the rebound side (three oval holes, shim diameter 36 mm) must face the lock nut!

Piston shaft

Pos. Description

1	Bump rubber
2	End cap
3	Circlip
4	Scraper
5	Support ring
6	X-ring
7	O-ring
8	Housing
9	Bushing
10	Seal head assy.
11	Stop rubber
12	Spacer
13	Adjustment pin
14	Stop ring
15	Shaft
16	Circlip
17	Adjustment needle
18	O-ring
19	Adjustment valve jet
20	Stop washer
21	Shim stacks
22	Piston
23	Piston ring
24	Stop washer, shim support
25	Washer
26	Lock nut
27	Screw
28	O-ring
29	O-ring
30	Piston

b

1114

3166

c

Fit the shim support washer.

Fit the compression shim stack, the damper piston and the rebound shim stack.

Fit the washer and the lock nut.

Tightening torque: 30 Nm.

Use a torque wrench when tighten the nut.

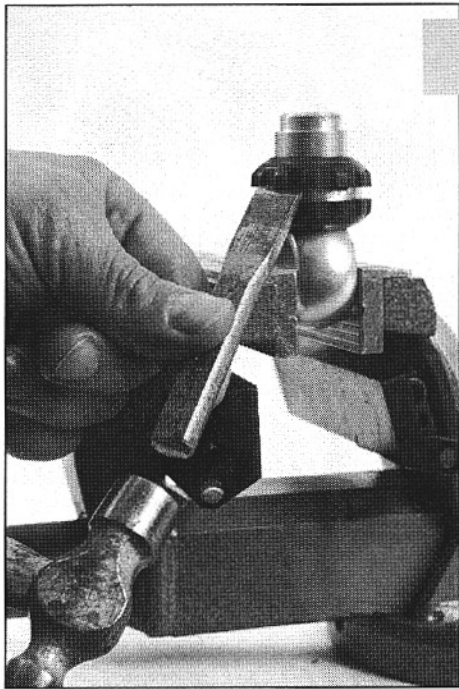

a

Replacing Adjustment wheel

Remove the spring clip support washer from the end eye (clevis) and split the adjustment wheel with a hammer and a small chisel.

Take out the small pin and replace the adjustment wheel body.

Use Öhlins grease 146-01 on the thread when install the new parts.

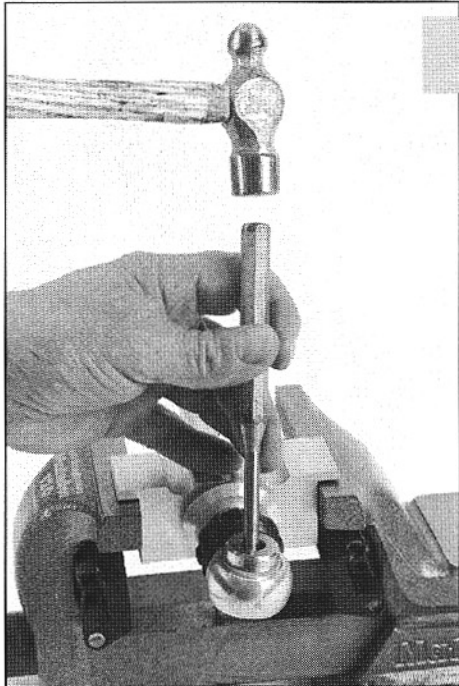
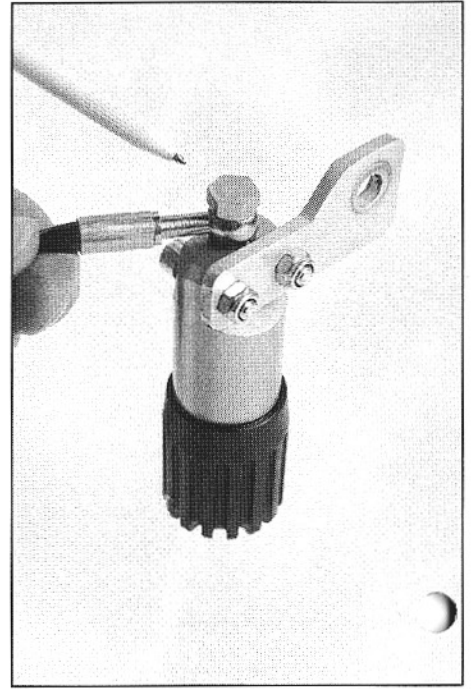

a

Replacing End eye (clevis)

Use a hammer and a drift to knock out the ball joint spacer.

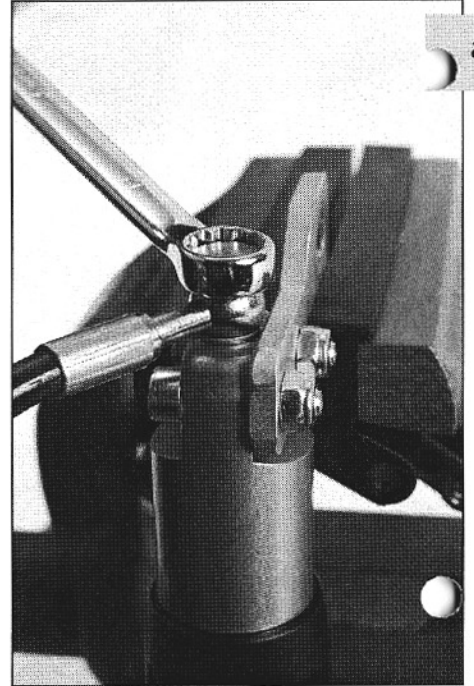

a

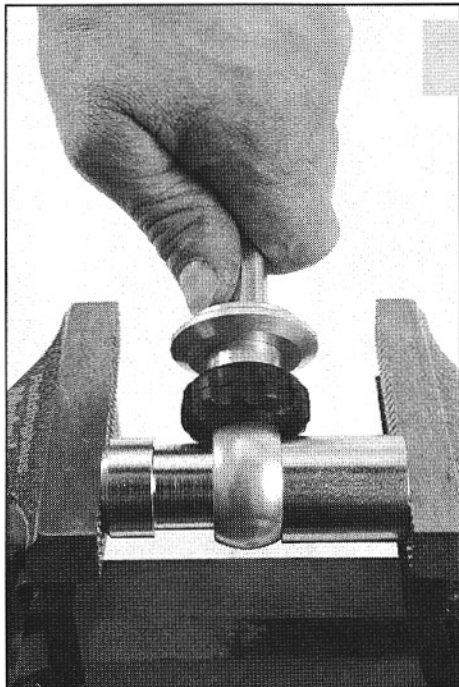

b

Use tool 721-01 and 723-01 to press out and install the ball joint.

NOTE

There is no need to lubricate the ball joints, the ball is gliding on a Teflon surface.

Lubricate the dust seals only with air filter oil.

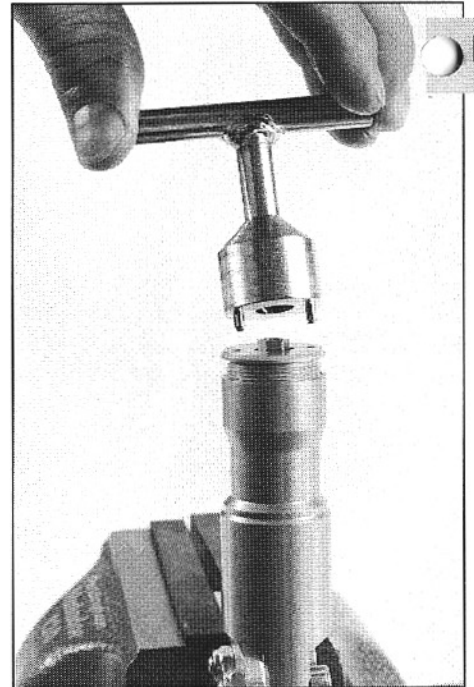

b

Dismantling

Hydraulic spring preload adjuster

NOTE

Before taking off the spring preload adjuster from the shock absorber, make a note of the hydraulic hose angle on relevation to the adjuster cylinder.

Remove the hydraulic hose from the adjuster cylinder and drain the oil.

Remove the adjuster knob and fasten the cylinder in a vice with soft jaws.

Remove the end cap, use tool 1754-01.

Remove the shaft assembly, use a suitable drift to press it out from the piston side.

Remove all o-rings and replace them with new ones.

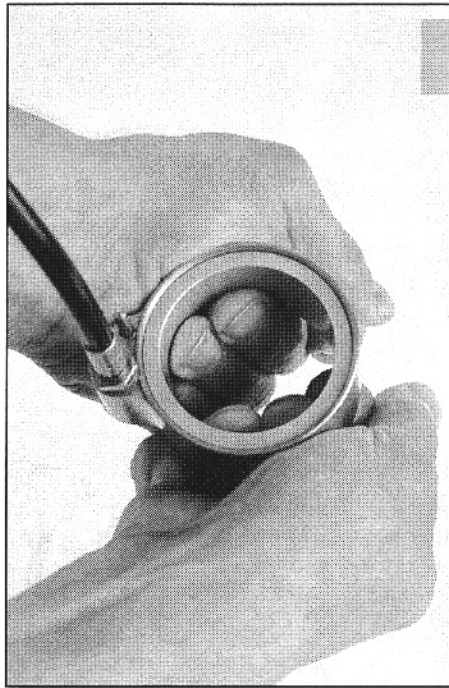

c

Remove the inner sleeve from the outer housing.

Remove and replace the two white guiding rings and all o-rings with new ones.

Clean all parts thoroughly.

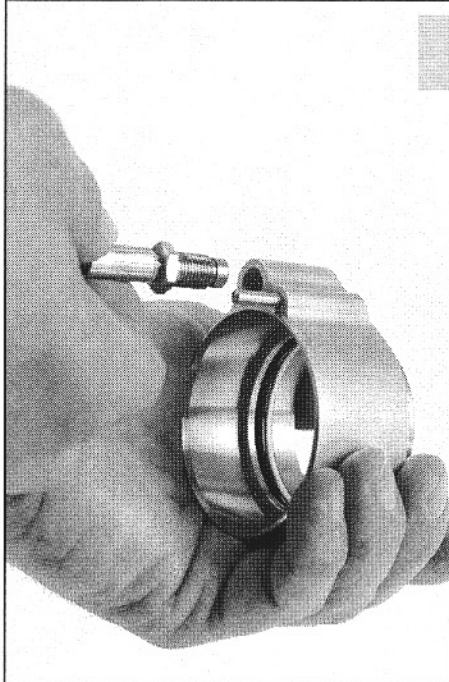

a

Assembling

Hydraulic spring preload adjuster

NOTE

Use Öhlins shock oil, 105-01 in the hydraulic adjuster.

Use Öhlins grease, 146-01 on all o-rings during assembling.

Fit the hydraulic hose on to the outer housing.

Tightening torque 30Nm.

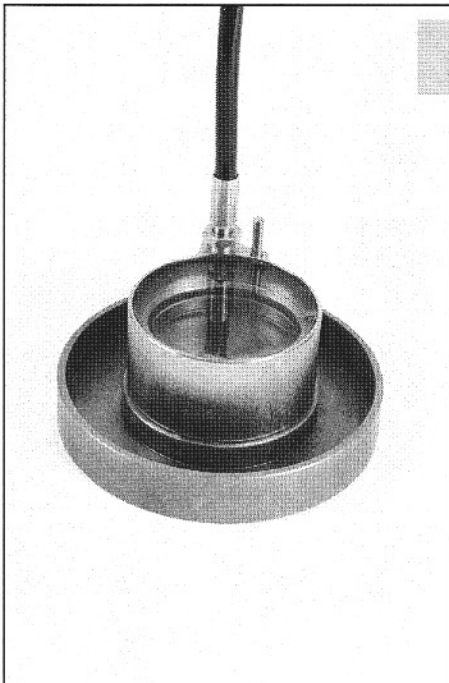

b

Fit the outer housing on tool 1786-01 and fill oil up to the top of the housing.

**c**

Install the inner sleeve into the outer housing.

Push the inner sleeve all way down to the bottom of the outer housing.

The air will bleed out through the hydraulic hose.

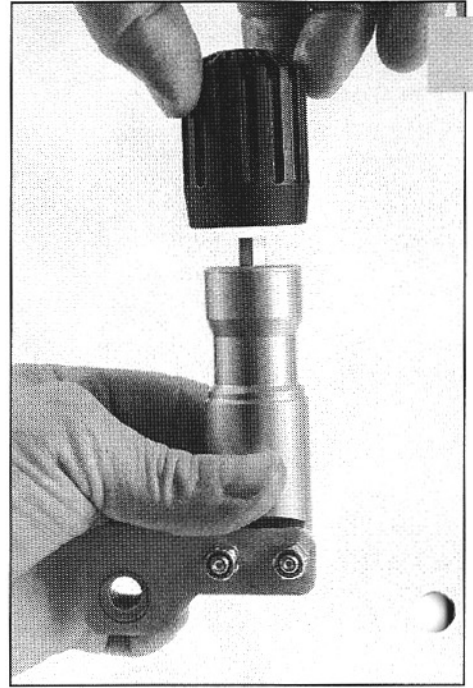
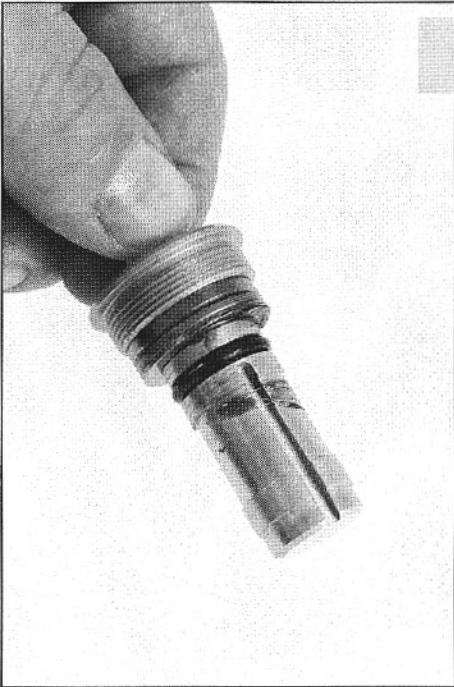
**f****d**

Use Öhlins grease 146-01 on the adjustment screw, the o-rings and the bearing.

Assemble all the parts to one unit (the adjustment screw, the piston, the bearing and all the o-rings).

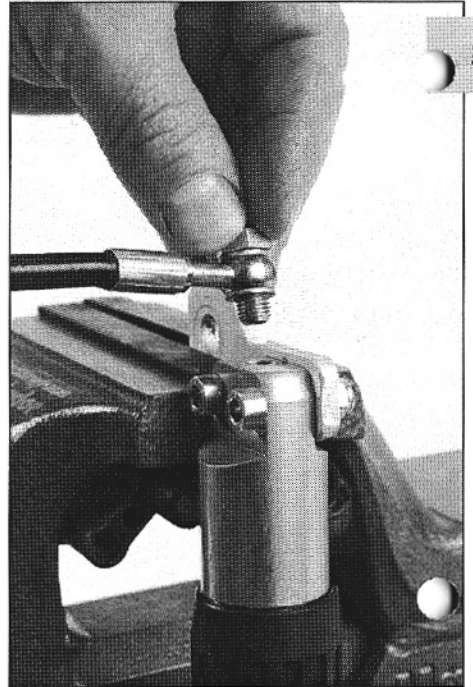
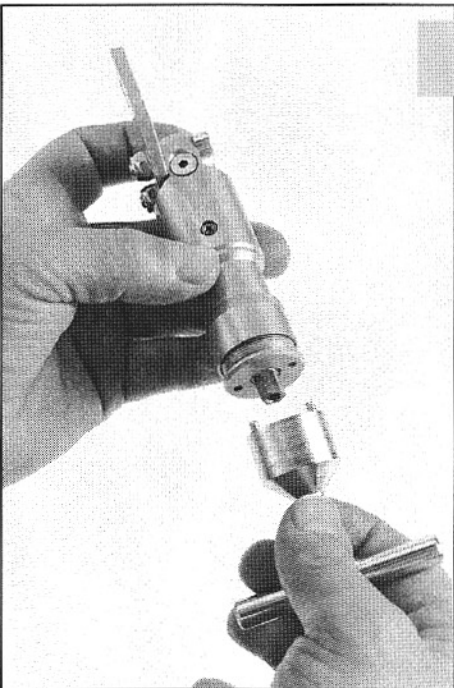
**g****e**

Install the piston shaft assembly into the adjusting cylinder.

Make sure it is in the right position for the guiding screw.

Tighten the cylinder end cap with tool 754-01.

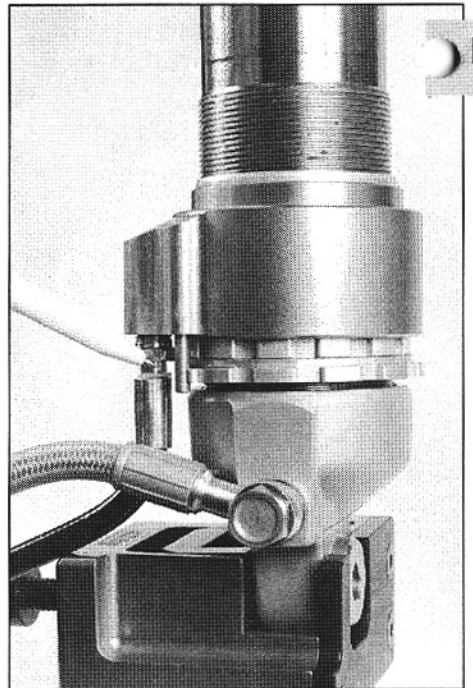
**h**

Öhlins distributors

Motorcycle shock absorbers

- Australia:** Steve Cramer Products, BRAESIDE 3195, Victoria, +61 3-587 14 66, fax +61 3-587 20 18.
- Austria:** Motopart Handelsges. m.b.H., 1230 WIEN, +43 1-667 66 28, fax +43 1-667 06 96.
- Canada:** Steen Hansen Racing Products, EDMONTON, Alberta T6B 0A8, +1 403-466 86 53, fax +1 403-465 94 83.
- Denmark:** F.I. Motorcykler ApS, 4180 SORÖ, +45 53-63 33 48, fax +45 53-63 48 55.
- Finland:** MP Racing, 05800 HYVINKÄÄ, +358 19-43 71 00, fax +358 19-48 98 72.
- France:** P.F.P - Öhlins France, 151 30 ARPAGON-SUR-CERE, +33 471-48 15 34, fax +33 471-64 25 93.
- Great Britain:** Harris Performance Products Ltd., HERTFORD, Herts. SG13 7AQ, +44 1992-55 10 26, fax +44 1992-58 70 52.
- Germany:** Zupin Moto-Sport GmbH, 83301 TRAUNREUT, +49 8669-85 76 0, fax +49 8669-23 28.
- Greece:** Vassilis Dulaveris, 117 43 ATHENS, +30 1-923 60 51, fax +30 1-924 99 57.
- Hong Kong:** Power Motorcycle Specialist, G/F, KOWLOON, +852 3903 949, fax +852 3919 434.
- Italy:** Motorquality S.p.A., 20099 SESTO S GIOVANNI (MI), +39 2-240 96 31, fax +39 2-224 764 20.
- Japan:** Carrozzeria Japan Co., Ltd., Urawa, SAITAMA-PREF, 336, +81 48-863 18 01, fax +81 48-863 18 02.
- Netherlands, Belgium, Luxembourg:** Wim Kroon Import V.O.F, 5451 HV MILL, +31 485-45 39 11, fax +31 485-45 48 48.
- Norway:** MC-Spesialisten, 1473 SKÅRER, +47 67-92 03 80, fax +47 67-97 28 55.
- New Zealand:** Hawera Motorcycles LMVD, TARANAKI, +64 6-278 41 60, FAX +64 6-278 65 52.
- Portugal:** Motoni, Alfragide, 2700 AMADORA, +351 1-471 35 11, fax +351 1-471 48 09.
- Singapore, Malaysia, Indonesia, Thailand:** Sporting Motorcycles, SINGAPORE 1232, +65 250 55 08, fax +65 253 63 12.
- Slovenia:** Moto ZIP trgovina d.o.o., 64000 KRANJ, +386 6426 85 15, fax +386 6426 85 14.
- Spain:** Zacatin S.A., 28850 TORREJON DE ARDOZ, +34 1-677 78 97, fax +34 1-677 61 23.
- Sweden:** Grahns Motor AB, 591 29 MOTALA, +46 141-545 80, fax +46 141-21 31 58.
- Switzerland:** 3W Motorsport, 8408 WINTERTHUR, +41 52-315 31 88, fax +41 52-315 37 54.
- Taiwan:** Henly Company Ltd, TAIPEI 10422, +886 2-537 56 00, fax +886 2-563 13 57.
- USA/Canada:** Parts Unlimited, JANESVILLE, WI 53547, +1 608-758-1111, fax +1 608-758-1144.
- Service Centre USA:** Pettersson Pro Suspension, ANAHEIM, CA 92807, +1 714-630-4777, fax +1 714-630-4788.
- Service Centre USA:** TUF Racing Products Inc., DEKALB, IL 60115, +1 815-756-3588, fax +1 815-756-3528.
- USA:** (MX/Enduro steering damp.): Scotts Performance Products, MONTROSE, CA 91020, +1 818-248-6747, fax +1 818-248-4529.

Snowmobile shock absorbers

- Canada:** Parts Unlimited, JANESVILLE, WI 53547, +1 608-758-1111, fax +1 608-758-1144.
- Service Centre Canada:** (All Öhlins shock absorbers): S. Hansen Racing Products, EDMONTON, ALBERTA T6B 0A8, +1 403-466-8653, fax +1 403-465-9483.
- Service Centre Canada:** (Öhlins Yamaha shock absorbers): Yamaha Motor Canada Ltd, NORTH YORK, ONTARIO M2H 3B4, +1 416-498-1911, fax +1 416-491-3122.
- Finland:** (All Öhlins shock absorbers): MP Racing, 05800 HYVINKÄÄ, +358 19-43 71 00, fax +358 19-48 98 72.
- Finland:** (Öhlins Yamaha shock absorbers): Oy Arvidson AB, 02271 ESPOO, +358 9-887 11, fax +358 9-887 12 92.
- Norway:** Yamaha Motor Norge A.S., 1401 SKI, +47 6-494 64 01, fax +47 6-494 58 08.
- Sweden:** Revelj Racing, 840 93 HEDE, +46 684-120 59, fax +46 684-122 75.
- USA:** Parts Unlimited, JANESVILLE, WI 53547, +1 608-758-1111, fax +1 608-758-1144.
- Service Centre USA:** Fast Inc., EVELETH, MN 55734, +1 218-744-2101, fax +1 218-744-5872.

Traction, handling,
comfort and safety



ADVANCED SUSPENSION TECHNOLOGY

Öhlins Racing AB, Box 722, S-194 27 Upplands Väsby, Sweden.
Phone +46 8 590 880 30, fax +46 8 590 882 17.